

Legislative Developments

Tax Increase Prevention and Reconciliation Act of 2005

Section 355(b) – Active Trade or Business Requirement

- **Section 355 as Amended by TIPRA: Section 355(b)(3) — Special Rule Relating to Active Business Requirement.**
 - This provision simplifies the active trade or business test for tax-free corporate spinoffs
 - Section 355(b)(3)(B) adopts an affiliated group rule that treats all members of a corporation's separate affiliated group as one corporation for purposes of satisfying the active trade or business requirement.
 - A corporation's separate affiliated group is the affiliated group which would be determined under section 1504(a) if such corporation were the common parent (regardless of whether section 1504(b) applies).
 - Effective date – The provision applies to distributions occurring after the date of enactment and before December 31, 2010, when it is set to sunset.

Section 355(b) — Example

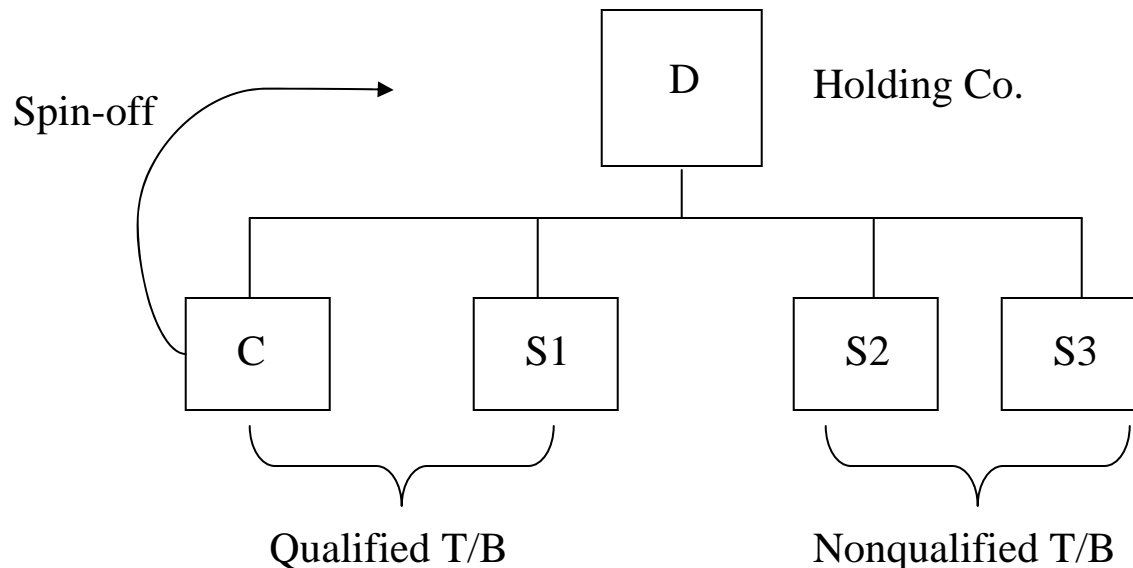

Facts: D is a holding company that wholly owns C, S1, S2, and S3, each of which is of equal value. C and S1 each engage in a qualifying 5-year active trade or business, but S2 and S3, having been acquired in taxable transactions within the past 5 years, do not. D wants to spin-off C to its shareholders.

Analysis: Under prior law, D would not have satisfied the active trade or business requirement, because substantially all of its assets are not stock or securities in subsidiaries that are so engaged. Section 355(b)(2). However, under section 355(b)(3)(B), D, S1, S2, and S3 will now be treated as one corporation engaged in S1's qualifying active trade or business.

Would the answer change if S1 were a foreign corporation?

Section 355(g) – Transactions Involving Disqualified Investment Companies

- **Section 355 as Amended by TIPRA: Section 355(g) — Transactions Involving Disqualified Investment Corporations.**
 - This provision denies Section 355 treatment if, immediately after the transaction:
 - Either the distributing or controlled corporation is a “disqualified investment corporation” and
 - Any person holds a 50% or greater interest of the disqualified investment corporation who did not hold such an interest prior to the transaction.
 - Section 355(g) defines a “disqualified investment corporation” as any distributing or controlled corporation if the fair market value of the investment assets of the corporation is:
 - 3/4 or more of the fair market value of all assets of the corporation (effective for one year period from the date of enactment), and
 - 2/3 or more of the fair market value of all assets of the corporation (effective after the end of the one year period from the date of enactment)
 - The term “investment assets” includes: cash, stocks, securities, interests in a partnership, debt instruments, options, forwards, notional principal contracts, derivatives, foreign currency, and other similar assets.

Section 355(g) -- Transactions Involving Disqualified Investment Companies (con't)

- The following are excluded from the term “investment assets”:
 - Assets used in active conduct of a lending, banking, or insurance business
 - Securities marked to market

- Rules relating to subsidiaries and partnerships owned by the distributing or controlled corporation:
 - Look-thru rule for 20% controlled entities – For purposes of computing percentages of investment assets, stocks or securities of a 20% subsidiary are not counted. Instead, the distributing or controlled corporation is treated as owning a ratable share of the subsidiary’s assets.
 - Look-thru rule for partnerships – Similarly, interests in a partnership are not counted if one or more of the businesses of the partnership (without regard to the 5-year requirement) would satisfy the active trade or business requirement.

- Effective date – The provisions contained in section 355(g) are effective for distributions after the date of enactment. However, section 355(g) does not apply to any transaction: (i) made pursuant to an agreement which was binding on the date of enactment; (ii) described in a ruling request submitted to the Service on or before such date; or (iii) described on or before such date in a public announcement or in a filing with the Securities and Exchange Commission

Section 355(g) — Example

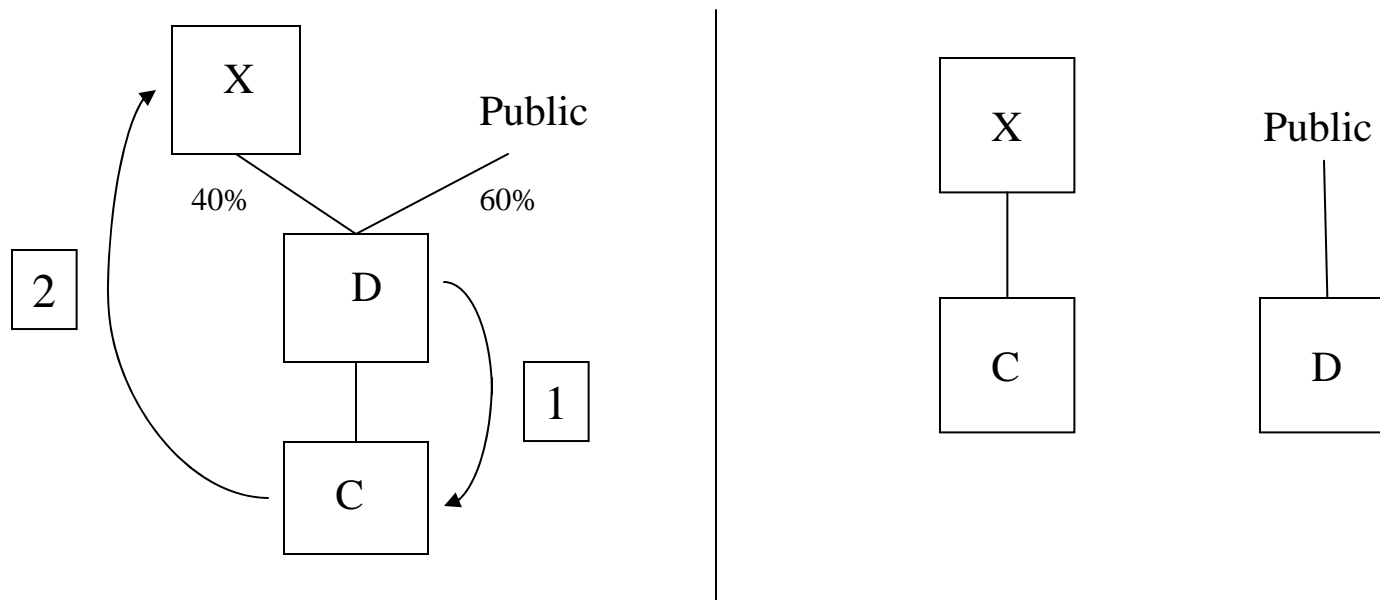

Facts: X owns a 40% interest in D; the rest of the D stock is publicly traded. For valid business purposes, D would like to redeem X's interest. To accomplish this, D creates a new entity, C, contributing to it an active trade or business with a value of \$30 and cash of \$70. D then distributes its C stock to X in exchange for X's D stock.

Analysis: In 2006, the provisions of 355(g) will not apply to this transaction as it satisfies the 3/4 test because the percentage of investment assets contributed to C is only 70 percent. However, this distribution would fail in 2007 under the 2/3 test. The more stringent percentage requirement will not become effective until one year after the subsection's enactment.

Regulatory and Administrative Developments

Section 351– Rev. Rul. 2006-2

Rev. Rul. 74-503

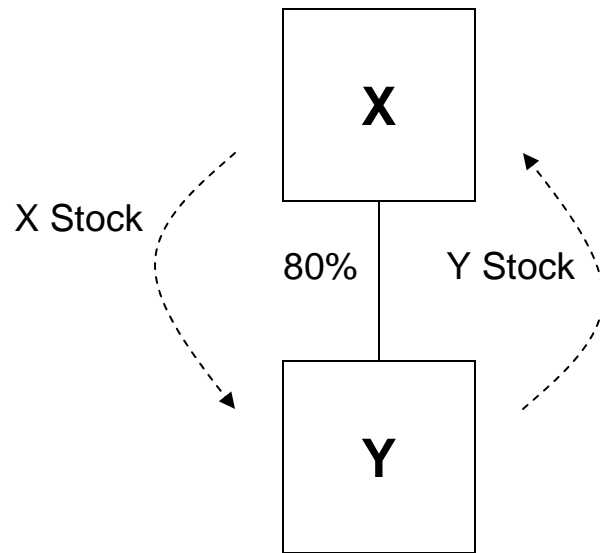

Authorities:

I.R.C. §§ 358(a), (e) and 362;
Treas. Reg. § 1.1032-1(d);
Rev. Rul. 74-503, 1974-2 C.B. 11.

Facts:

- Corporation X transferred shares of its treasury stock to corporation Y in exchange for newly issued shares of Y.

Holding:

- Under Section 358(e), Section 358 does not apply to determine X's basis in Y's stock.
- X's basis in the Y shares is zero, as determined under Section 362(a).
- Y's basis in the X shares is zero under Section 362(a).

Section 358(e)

“Exception. [Section 358] shall not apply to property acquired by a corporation by the exchange of its stock or securities (or the stock or securities of a corporation which is in control of the acquiring corporation) as consideration in whole or in part for the transfer of property to it.”

Rev. Rul. 2006-2

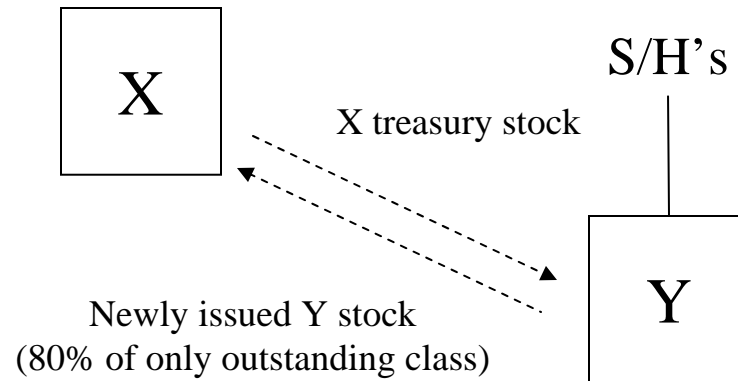

Facts: In Rev. Rul. 74-503, 1974-2 C.B. 117, X corporation transferred shares of its treasury stock (with a FMV of \$3,000x and purchased by X several years previously from its shareholders for \$2,000x) to Y in exchange for newly issued shares of Y stock (with a FMV of \$3,000x) which constituted 80 percent of the only outstanding class of stock of Y. Rev. Rul. 74-503 determined that (i) X's transfer of its X stock to Y for Y stock is a section 351 transaction, (ii) X has a 0 basis in its own stock, and (iii) under section 362, Y takes a 0 basis in X stock received and X takes a 0 basis in the Y stock received.

Result: Rev. Rul. 2006-2 revokes Rev. Rul. 74-503, effective December 20, 2005. The ruling states that the conclusion in Rev. Rul. 74-503 that the basis in the Y stock received by X in the exchange is determined under section 362(a) is incorrect. The ruling also states that the other conclusions in Rev. Rul. 74-503, including the conclusions that X's basis in the Y stock received in the exchange and Y's basis in the X stock received in the exchange are zero, are under study.

Analysis: Even if the transfer of X stock for Y stock is a section 351 transaction, section 362 does not apply to determine X's basis in the Y stock. Section 362 only applies to the transferee in a section 351 transaction. Section 358 generally applies to the transferor in a section 351 transaction. However, Rev. Rul. 74-503 determined that section 358 does not apply in this case because it does not apply to property acquired by a corporation in exchange for its own stock. *See* section 358(e). Because section 362 does not apply and section 358 does not apply, it is unclear what code provision determines X's basis in the Y stock.

D Reorganizations

'D' Reorganizations -- Direct Ownership

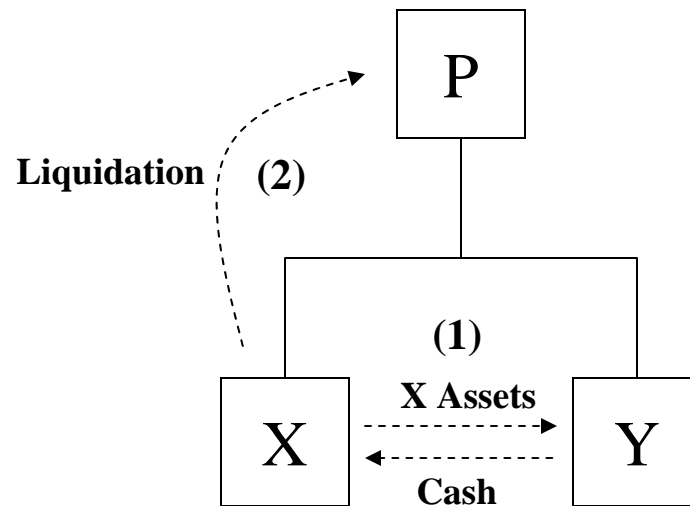

Facts: P owns all of the stock of X and Y. X transfers its assets to Y in exchange for cash and immediately thereafter liquidates into P.

Result: The transaction will be treated as a 'D' reorganization because the distribution of Y stock would constitute a meaningless gesture. See Rev. Rul. 70-240. Note that the same result would obtain if P transferred X stock to Y in exchange for cash and, immediately thereafter, X liquidated into Y. See Rev. Rul. 2004-83.

'D' Reorganizations -- Indirect Ownership

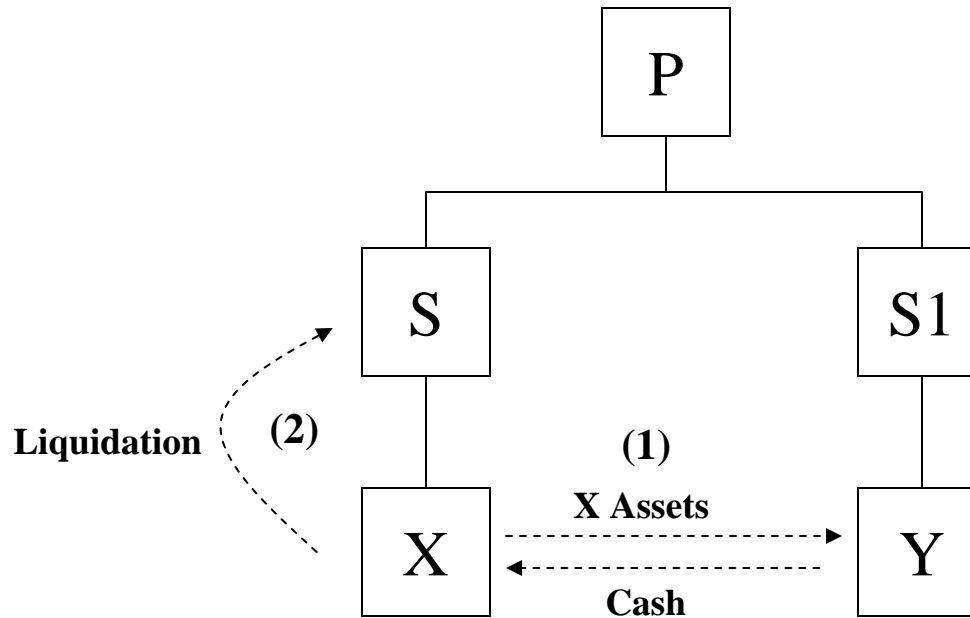

Facts: P owns all of the stock of S and S1. S owns the stock of X and S1 owns the stock of Y. X transfers its assets to Y in exchange for cash and immediately thereafter liquidates into S.

Result: The transaction should qualify as a 'D' reorganization because Y stock is treated as being distributed up the chain to P and then back down. See PLR 8911067; PLR 9229026. In the consolidated return context, the following events are deemed to occur: (i) Y is treated as issuing its stock to X in exchange for X's assets; (ii) X is treated as distributing Y stock to S in a liquidation; and (iii) Y is treated as redeeming its stock from S for cash. See Treas. Reg. section 1.1502-13(f) and (f)(7), ex. 3.

'D' Reorganizations -- Constructive Ownership

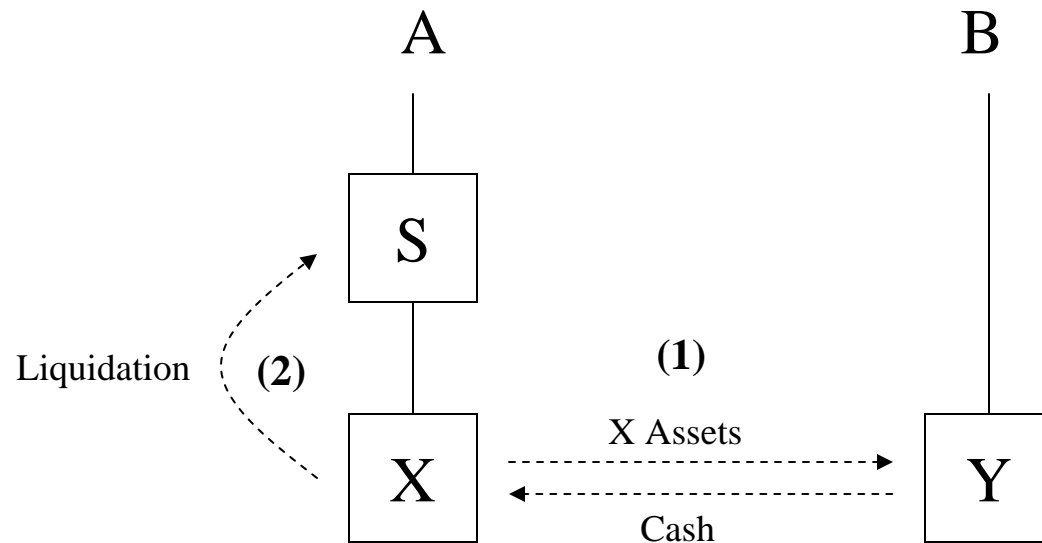

Facts: A and B are mother and son. A owns the stock of S which owns the stock of X. B owns the stock of Y. X transfers its assets to Y and immediately thereafter liquidates into S.

Result: Has there been a 'D' reorganization? Does S control Y after the transaction? Would a distribution of Y stock be a meaningless gesture? See PLR 9111055.

'D' Reorganizations -- PLR 200551018

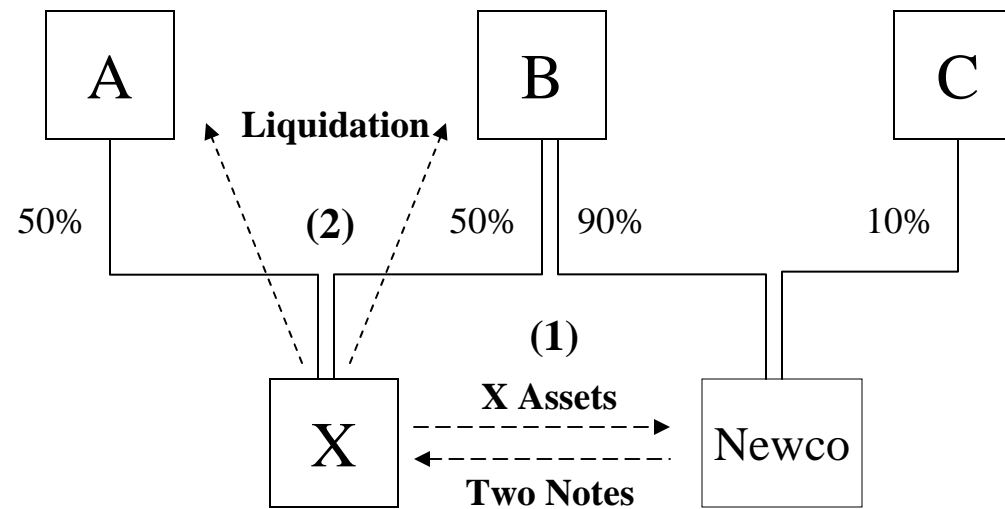

Facts: A and B own 50 percent of the stock of X. B and C own Newco, with B owning 90 percent and C owning 10 percent of the stock, respectively. X Corporation transfers its assets to Newco in exchange for two notes. Immediately thereafter, X liquidates, distributing one note to each A and B.

Result: PLR 200551018 assumes that the transaction does not qualify as a 'D' reorganization in holding that Newco is entitled to amortize the cost of goodwill acquired as a result of the purchase of X assets.

Final Basis Determination Regulations

Shares Acquired at Multiple Times

- Date 1** – 20 shares, \$3/share
- Date 2** – 10 shares, \$6/share
- Date 3** – T stock FMV = \$10/share
A stock FMV = \$20/share

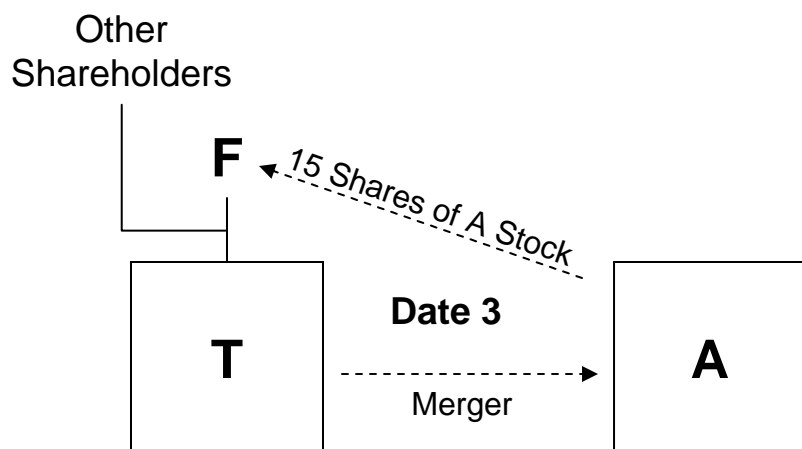

Authorities:

I.R.C. §§ 354 and 358;
Treas. Reg. §§ 1.358-2(c) Ex. 1,
1.358-2(a)(2)(i) and (vii).

Facts:

- F receives 1 share of A stock for every 2 shares of T stock under the terms of an “A” reorganization.
- F is not able to identify which shares of A stock are received in exchange for which shares of T stock.

Result:

- F has 15 shares of A stock:
 - 10 shares have a \$6 basis per share and are treated as having been acquired on Date 1.
 - 5 shares have a \$12 basis per share and are treated as having been acquired on Date 2.
- On or before the date on which the basis of a share of A stock received becomes relevant, F may designate which shares have which basis.

Allocation of Boot (1)

Date 1 – 20 shares, \$3/share

Date 2 – 10 shares, \$6/share

Date 3 – T stock FMV = \$10/share

A stock FMV = \$20/share

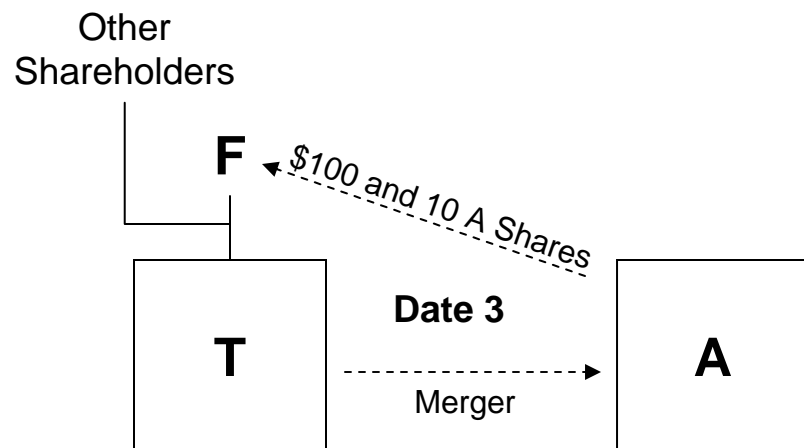

Authorities:

I.R.C. §§ 354, 356 and 358;

Treas. Reg. §§ 1.356-1(a) and (b); 1.358-2(c) Ex. 1;

1.358-2(a)(2)(i) and (ii);

Preamble to Treas. Reg. § 1.358-2.

Facts:

- In an “A” reorganization, F receives 10 A shares and \$100 in cash in exchange for 30 T shares, 20 with a low basis and 10 with a high basis.

Analysis:

- If (economically reasonable) terms of the exchange so specify, cash consideration may be allocated entirely to high-basis shares:
 - F will recognize \$40 of aggregate gain -- \$40 on the high-basis shares and none on the low-basis shares.
 - F’s 10 A shares will each have a basis of \$6 and be treated as having been acquired on Date 1.
- If the terms of the exchange do not specify otherwise, the allocation will be pro-rata:
 - F will recognize \$100 of aggregate gain -- \$66.67 on the low-basis shares and \$33.33 on the high-basis shares.
 - F will hold 6 A shares having a \$9 basis (treated as acquired on Date 1), 3 shares having an \$18 basis (treated as acquired on Date 2), and 1 share with a split basis and holding period.

Query:

- In a public transaction, what does it mean for the terms of the exchange to specify an allocation?

Allocation of Boot (2)

Date 1

100 shares T common:
\$10 aggregate basis, \$100 FMV
100 shares T non-voting preferred:
\$90 aggregate basis, \$100 FMV

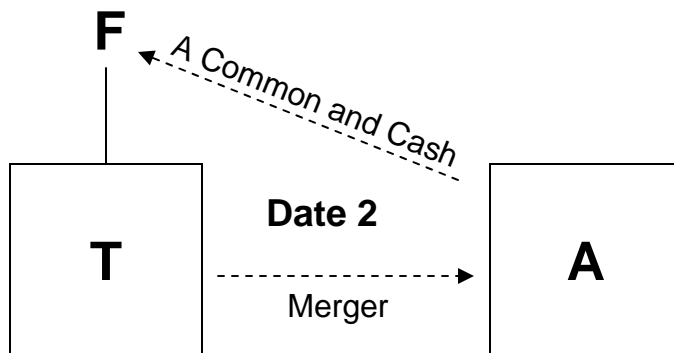

Authorities:

I.R.C. §§ 354, 356 and 358;
Preamble to Treas. Reg. §1.358-2;
Treas. Reg. §§ 1.356-1(a) and (b);
1.358-2(a)(2)(i) and (ii).
Cf. Rev. Rul. 74-515.

Facts:

- In the merger agreement, the terms of the exchange specify that F exchanges its T common stock for 100 shares of P common stock with a value of \$100 and its shares of T preferred stock for \$100 of cash.

Result:

- The terms of the reorganization control.
- Common Stock:
 - The \$90 realized gain is not recognized.
 - F has an aggregate basis of \$10 in A common stock.
- Preferred Stock:
 - The \$10 realized gain is recognized.
 - F has an aggregate basis of \$100 in the \$100 of cash.

Query:

- What is the result if F has a basis in the T preferred of more than \$100?

Scope of Rules on Allocation of Boot

Date 1

100 shares T common:

\$10 aggregate basis, \$100 FMV

100 shares T non-voting preferred:

\$100 aggregate basis, \$100 FMV

P Common Stock, FMV = \$178,
plus Cash = \$22

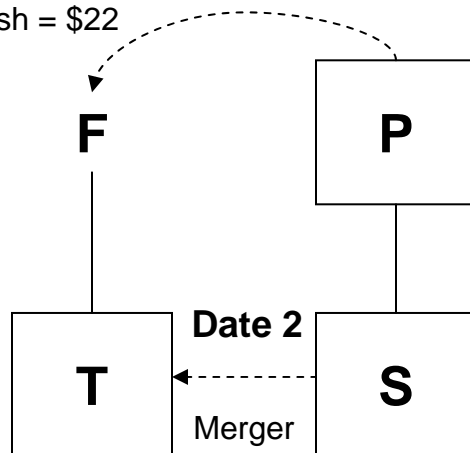

Authorities:

I.R.C. §§ 354, 356 and 358;
Treas. Reg. §§ 1.356-1(a)(b); 1.358-2(a)(2)(i)
and (ii).

Facts:

- In a reverse triangular merger, F exchanges low-basis common stock and high-basis preferred stock for cash and common stock.

Analysis:

- The merger agreement presumably can control the allocation of cash and P stock received to the common and preferred T shares surrendered in a reorganization for purposes of Sections 356 and 358.
- What allocation rules apply for determining whether the exchange qualifies as a reorganization in the first place?
 - Can the parties allocate all cash to the preferred stock for purposes of Sections 356 and 358 when such allocation, if respected in applying Section 368, would prevent the exchange from qualifying as a reorganization?
 - Can the parties cause the exchange to be a Section 338 QSP by allocating all cash to the T common stock (or to the T preferred stock), even though the rule providing for such allocations are in regulations that, by their terms, apply only in certain nonrecognition transactions?

Structuring Multiple Section 355 Transactions

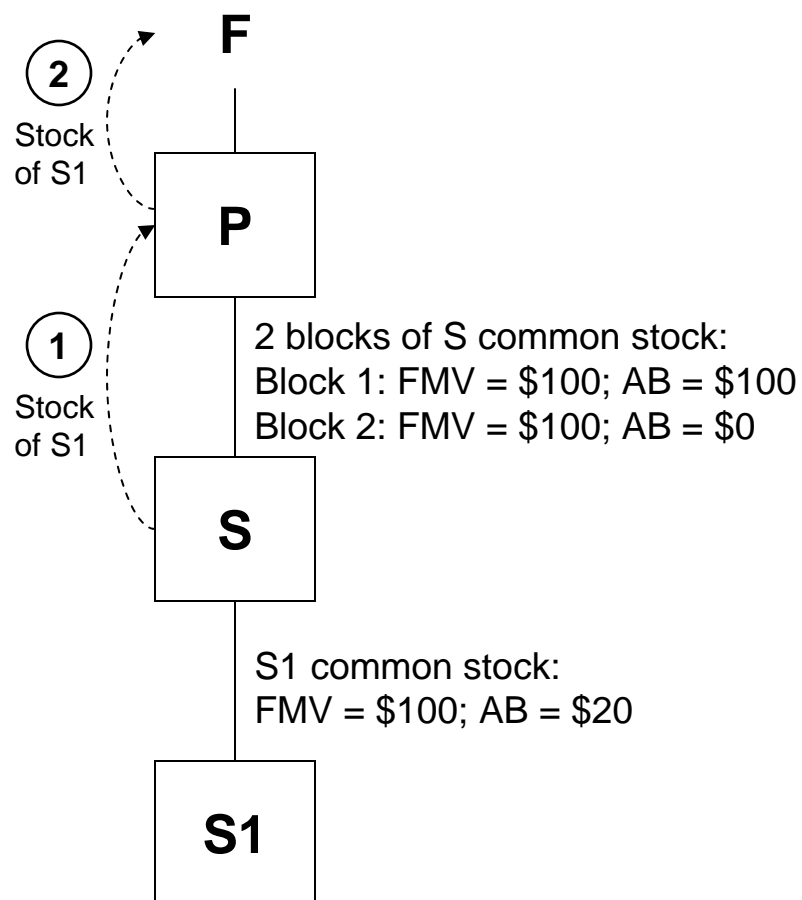

Facts:

- In distributions under Section 355, **S** distributes to **P**, and **P** in turn distributes to its shareholders, the common stock of **S1**.

Analysis:

- **P**'s basis in its **S** shares after the transaction may depend on the form of the first distribution:
 - In a spin-off, **P**'s basis in its **S** shares would be split between those shares and the **S1** shares received (so **P** would have a post-spin basis of \$50 in both the **S** and **S1** stock).
 - Instead, can the transaction be structured as a split-off in which **P** surrenders its \$0-basis **S** shares for the **S1** shares and keep its \$100 basis in the retained **S** shares?

Note: The basis in shares of **S1** that **P** receives in a multiple distribution case generally is irrelevant to **P** (because **P** generally will recognize no gain or loss in the second distribution) and to **F** (whose basis in **S1** is not based on **P**'s basis).

Authorities:

I.R.C. §§ 355 and 358;
Treas. Reg. §§ 1.358-2(c) Ex. 12 & 13;
1.358-1(a); 1.358-2(a)(2)(i) and (iv).

Recapitalizations

Date 1

100 shares of Class A common:
\$10 aggregate basis, \$100 FMV
100 shares of Class B common:
\$100 aggregate basis, \$100 FMV

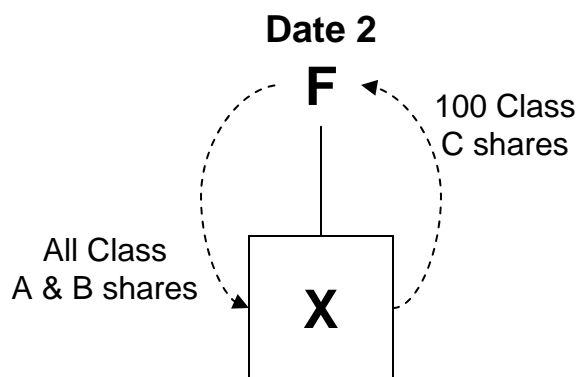

Authorities:

I.R.C. §§ 354 and 358;

Treas. Reg. §§ 1.358-2(a)(i) and (ii).

Facts:

- F owns 100 shares of each of the two outstanding classes of stock of X. All shares of the same class were acquired on the same date.
- In a recapitalization of X, F receives 100 Class C common stock for all its Class A and B shares.

Result:

- Can the agreement governing the exchange specify that 1 share of Class C common is issued in exchange for 1 share of Class A common and 1 share of Class B common?
- There does not appear to be any authority under the regulations permitting such an allocation.
- Rather, under the regulations, each Class C share must reflect, to the greatest extent possible, the bases of 2 surrendered shares with the same basis and holding period, which in this case means 2 shares of the same class.
- Accordingly, F apparently would receive 50 shares of Class C stock, with an aggregate basis of \$10 and 50 shares with an aggregate basis of \$100, regardless of the allocation set forth in the agreement.

Merger Transactions Involving Disregarded Entities

Multiple Disregarded Entities

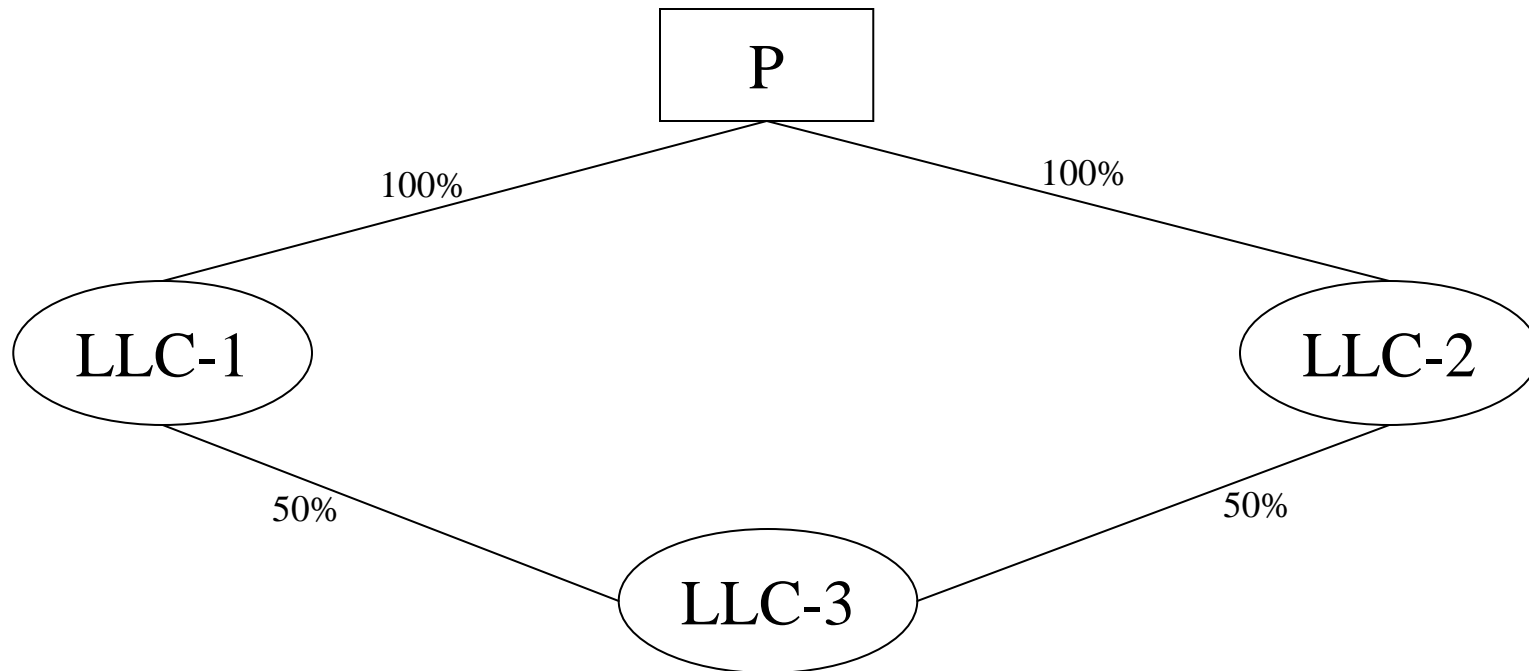

Facts: Corporation P is the sole member of LLC-1 and LLC-2, both of which do not elect to be taxed as associations. LLC-1 and LLC-2 form LLC-3, with each taking a 50 percent membership interest.

Sale of Membership Interests to Other Member

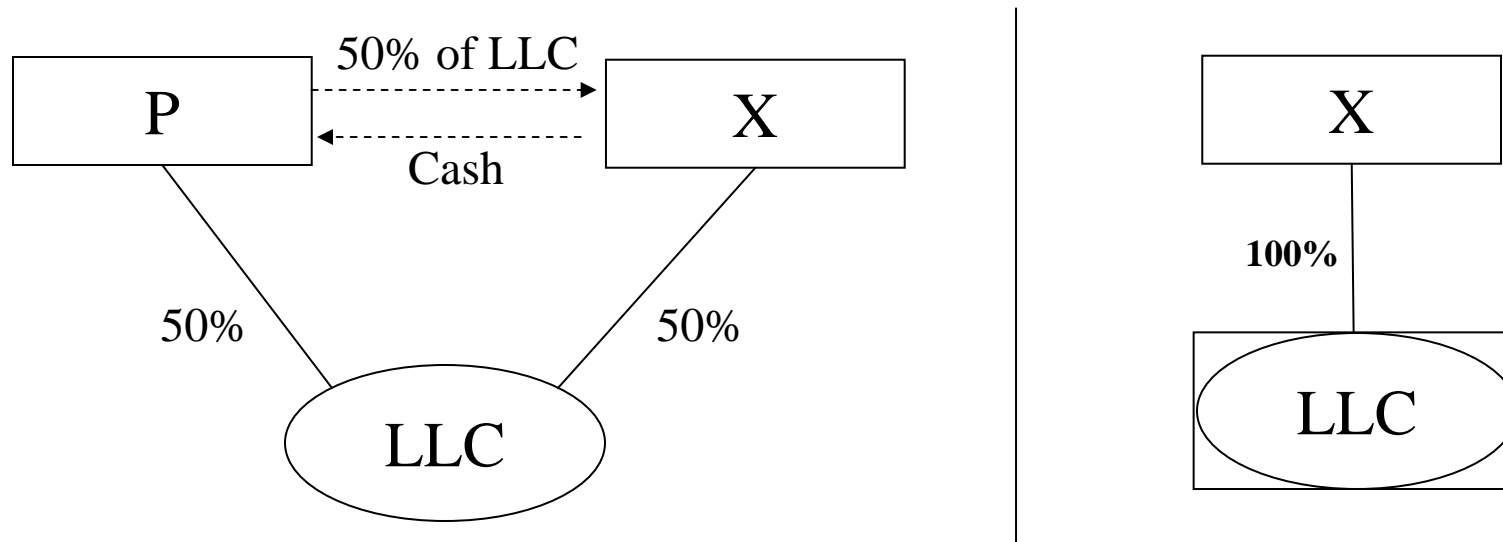

Facts: P and X each own a 50% interest in LLC. P sells its 50% LLC interest to X. After the sale, X is the sole owner of LLC, which is disregarded as an entity separate from X.

Results: The partnership terminates under section 708(b)(1)(A) when X purchases P's interest. P treats the transaction as a sale of a partnership interest. However, for purposes of determining the consequences to X, LLC is deemed to make a liquidating distribution of all of its assets to P and X, and X is treated as acquiring the assets distributed to P. *See* Rev. Rul. 99-6. What if P and X are members of a consolidated group? *See* P.L.R. 200334037.

Sale of All of the Membership Interests

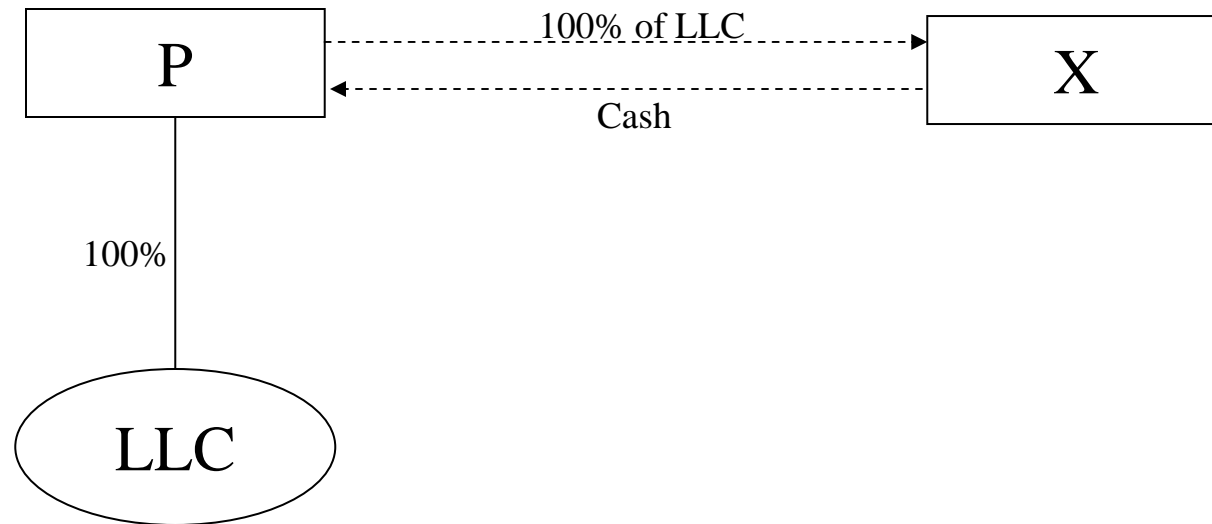

Facts: P owns all of the outstanding interests in LLC, which is treated as a disregarded entity for tax purposes. The fair market value of LLC's assets is \$100, and their adjusted basis is \$50. P sells all of the outstanding membership interests in LLC to X, an unrelated party, for \$100.

Results: Because P is treated as owning all of the assets of LLC rather than LLC interests, P is treated as selling all of the assets of LLC to X.

Sale of Less than All of the Membership Interests

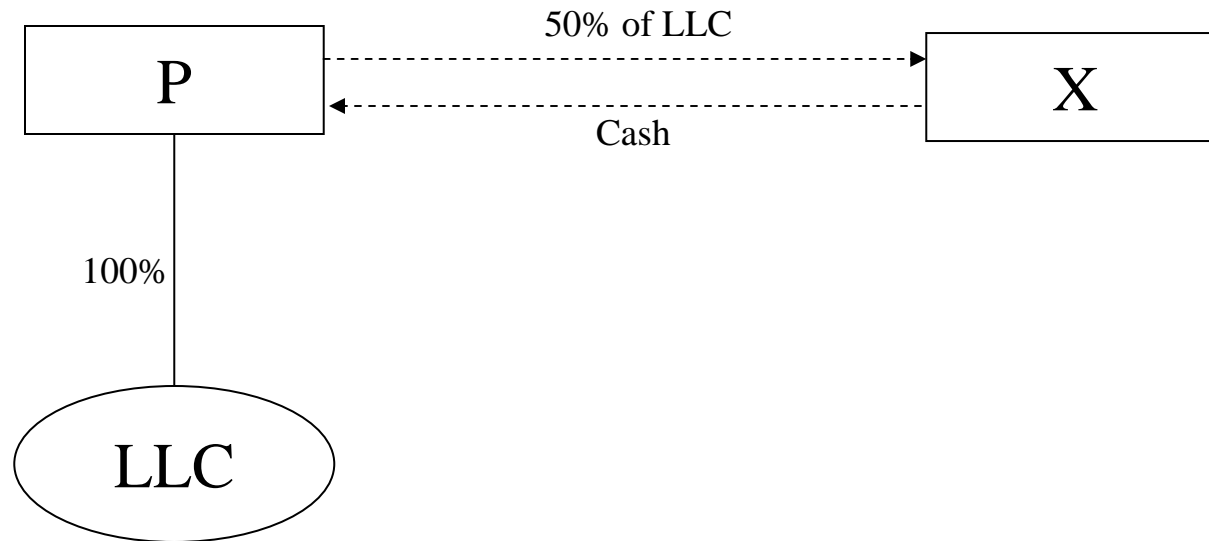

Facts: P owns all of the outstanding interests in LLC, which is treated as a disregarded entity for tax purposes. P sells 50 percent of the outstanding membership interests in LLC to X, an unrelated party.

Results: P is treated as having sold 50% of LLC's assets to X, followed by a contribution by X of the purchased assets and by P of the retained assets to a newly formed partnership. Reg. § 301.7701-3(g)(1)(iv), (g)(3)(i); Rev. Rul. 99-5 (Sit. 1).

What are the results if, instead of P's selling the interests to X, X contributes cash to LLC in exchange for interests? *See* Rev. Rul. 99-5 (Sit. 2). What if P sells 50 percent of the LLC's interests in a public offering? *See* section 7704.

Sale of Less than All of the Membership Interests

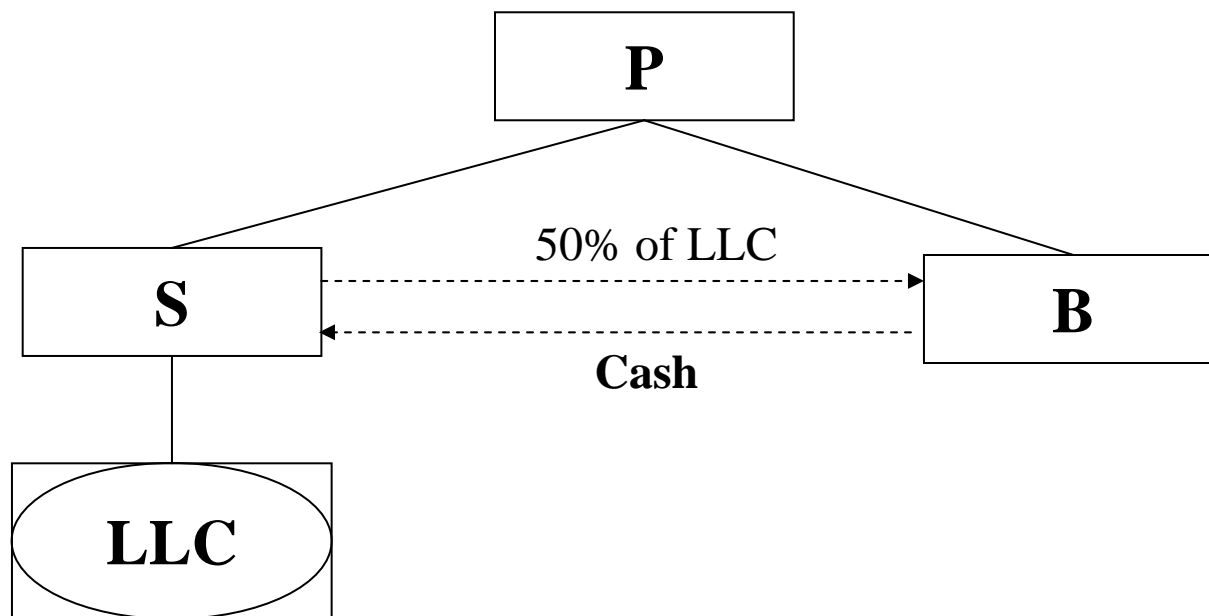

Facts: S and B are members of a consolidated group. S owns all of the outstanding interests in LLC, which is treated as a disregarded entity for tax purposes. S sells 50 percent of the outstanding membership interests in LLC to B.

Results: S is treated as having sold 50% of LLC's assets to B in an intercompany sale, followed by a contribution by B of the purchased assets and by S of the retained assets to a newly formed partnership. Reg. § 301.7701-3(g)(1)(iv), (g)(3)(i). Thus, gain on the sale from S to B is triggered under Reg. § 1.1502-13(d). A better result is obtained if B contributes cash directly to LLC, so that there is no sale between S and B. However, if that cash is distributed to S within 2 years, S will be subject to the disguised sale rules under section 707(a)(2)(B).

Deemed Liquidation and Asset Sale of CFC; *Dover Corp. v. Commissioner*

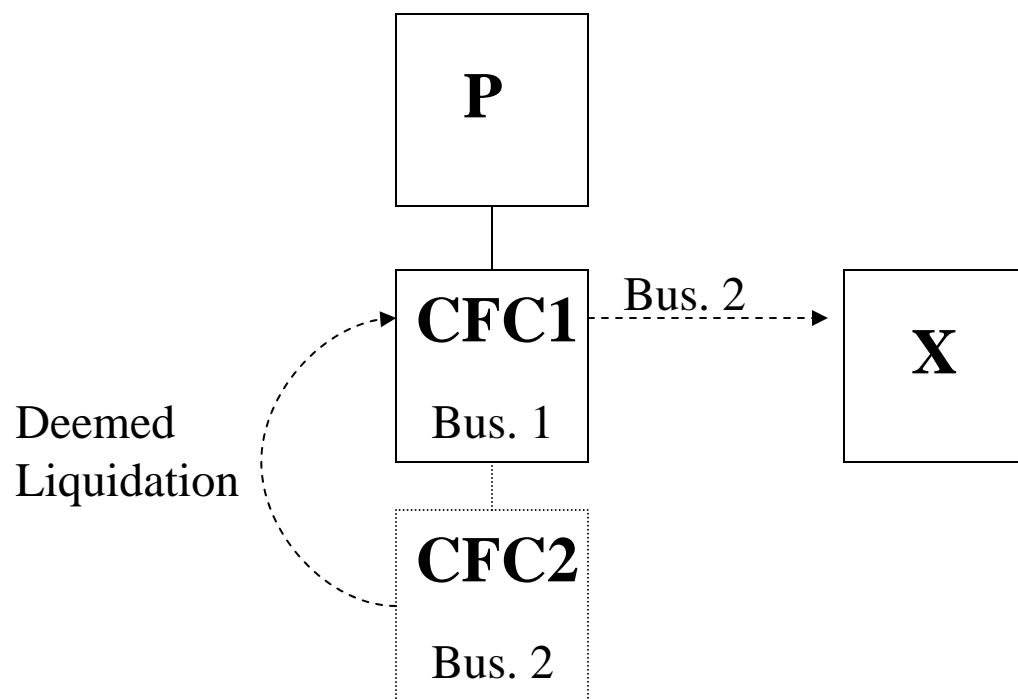

Facts: P owns 100 percent of CFC1, which engages in business 1. CFC1 owns 100 percent of CFC2, which engages in business 2. CFC1 and CFC2 are controlled foreign corporations incorporated in the United Kingdom. On Date 1, CFC1 checks-the-box for CFC2, which results in a deemed section 332 liquidation of CFC2. Immediately thereafter, CFC1 sells all of the assets of business 2 (i.e., CFC2 assets) to X for cash.

Issue: Does the transaction result in subpart F income? *See Dover Corp. v. Commissioner*, 122 T.C. No. 19 (May 5, 2004); *see also* Rev. Rul. 75-223, 1975-2 C.B. 109.

Overlap Between Automatic and Elective Changes In Classification

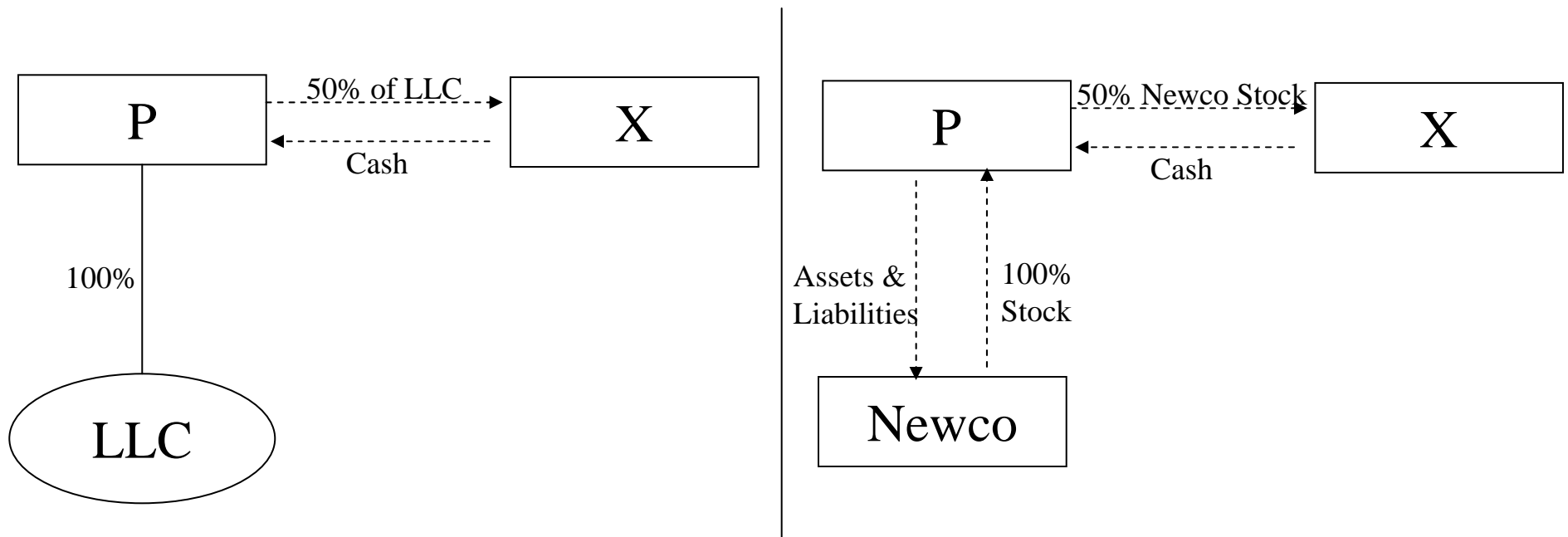

Facts: P owns all of the outstanding interests in LLC, which is treated as a disregarded entity for tax purposes. On January 1, 1998, P sells 50 percent of the outstanding membership interests in LLC to X, an unrelated party. P and X elect to treat the entity as an association effective January 1, 1998.

Results: The elective classification changes preempt the automatic classification change resulting from the change in the number of owners. Thus, P is treated as contributing all of the assets and liabilities of LLC to Newco and selling 50% of the Newco stock to X. *See* Reg. § 301.7701-3(f)(4), Ex. 1.

Merger of Corporation Into Single-Member LLC

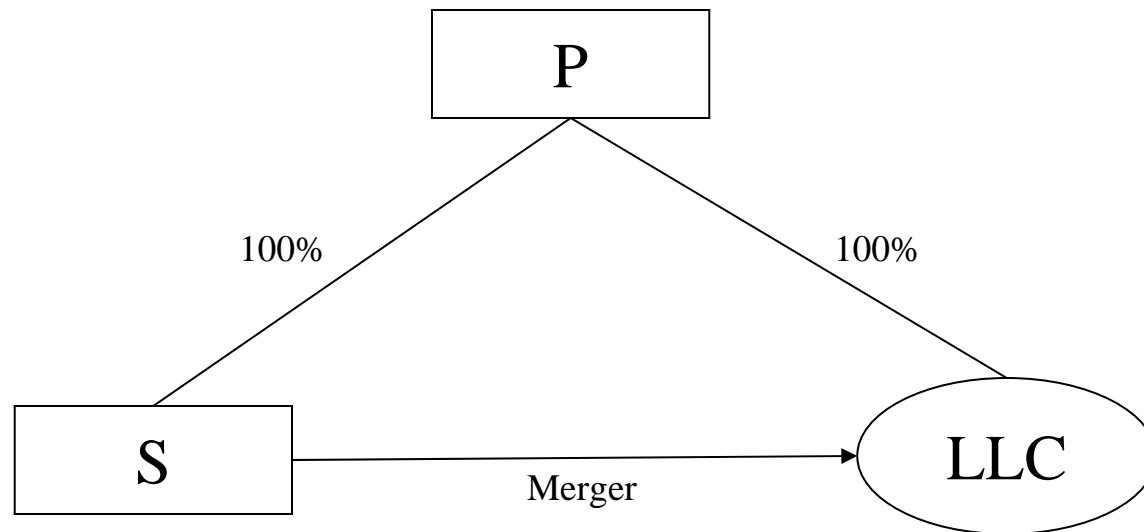

Facts: Corporation P owns all of the stock of S Corporation and all of the membership interests in LLC. LLC does not elect to be taxed as an association. S is merged into LLC pursuant to Delaware General Corporation Law section 264 (which permits the merger or consolidated of a Delaware corporation with an LLC). Pursuant to the merger, all of S's assets and liabilities are transferred to LLC, and S's separate corporate existence ceases. See P.L.R. 9822037 (Feb. 27, 1998).

B Reorganization

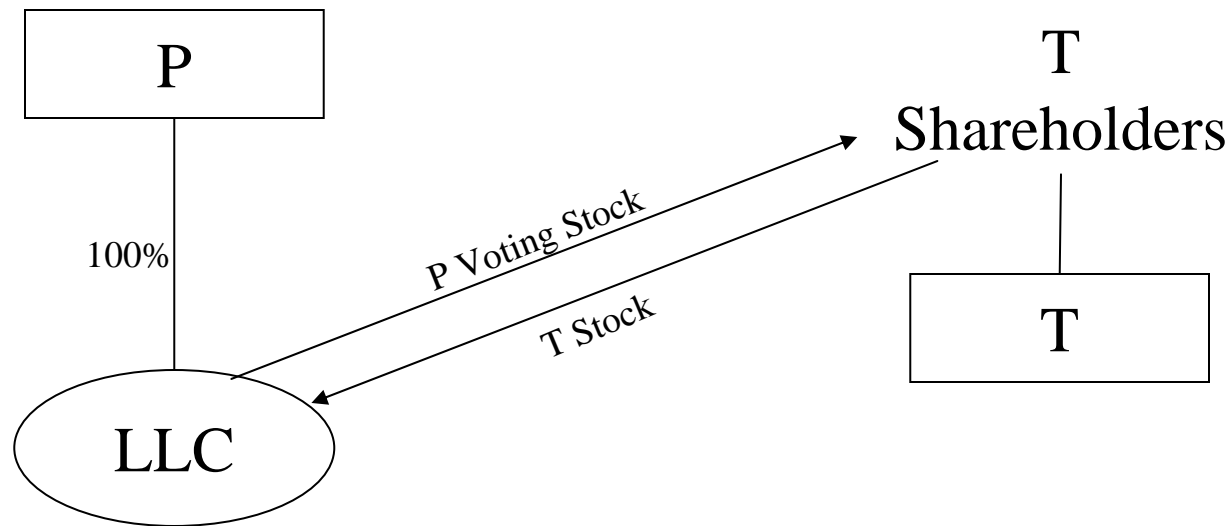

Facts: P forms a wholly owned LLC. LLC does not elect to be taxed as an association and is, thus, treated as a disregarded entity. LLC acquires T stock from the T shareholders in exchange for P voting stock.

C Reorganization

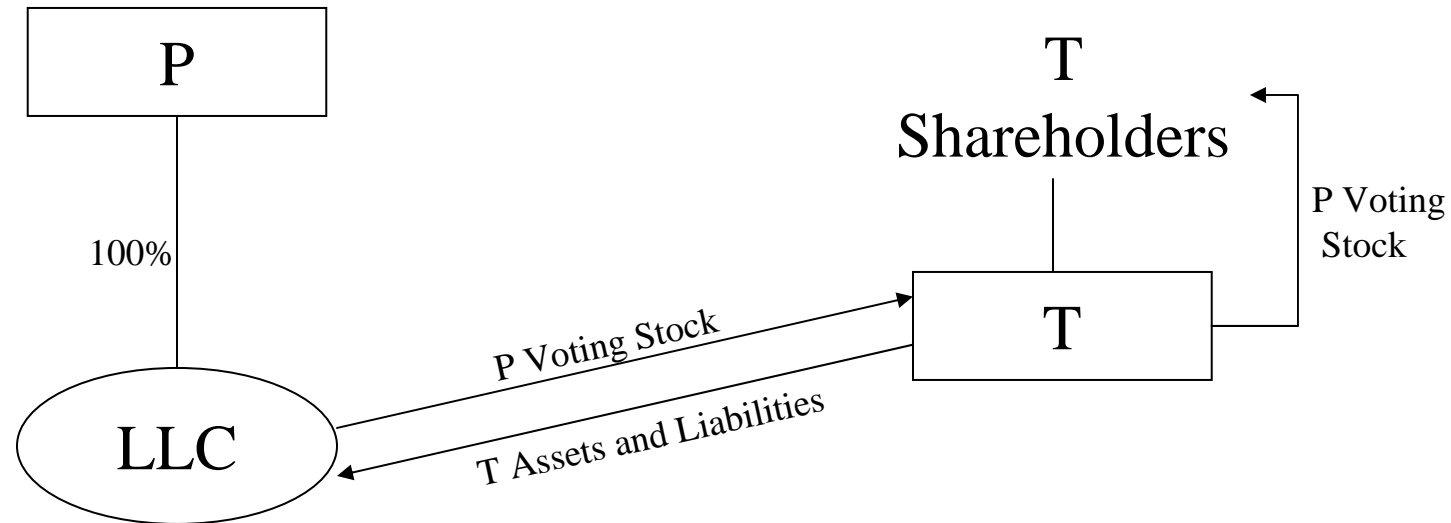

Facts: P forms a wholly owned LLC, which is treated as a disregarded entity, with P voting stock. P wants LLC to acquire T in a tax-free reorganization. T has assets worth \$100 and has recourse liabilities of \$30. LLC transfers its shares of P voting stock to T in exchange for all of T's assets and liabilities. T distributes all of the P voting stock to its shareholders in complete liquidation.

D Reorganization

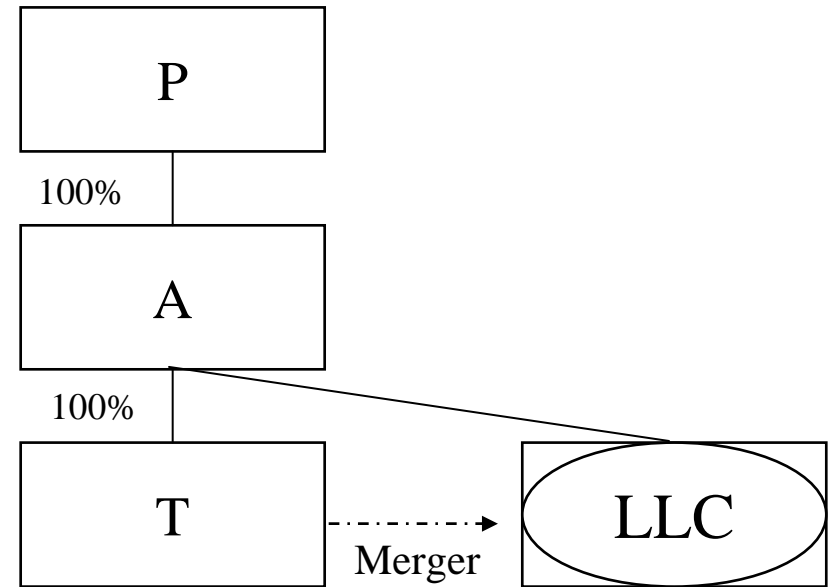
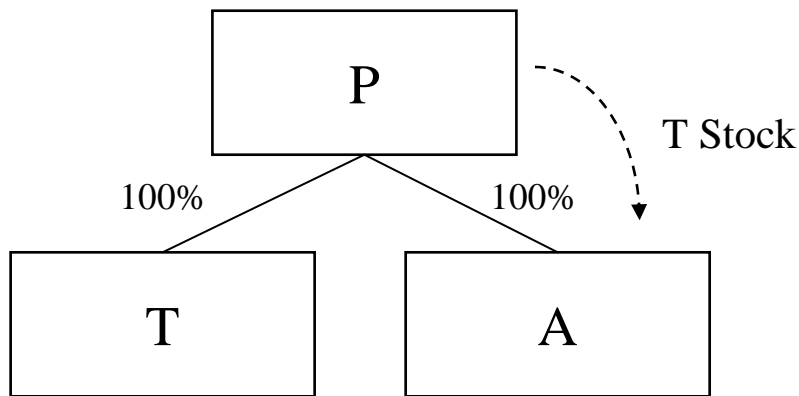

Facts: P owns all of the stock of two corporations, T and A. P contributes all of its T stock to A. Immediately thereafter, A forms a wholly owned LLC, and T merges into LLC.

Result: The contribution of T stock and the subsequent merger of T into LLC should be integrated and treated as if T transferred all of its assets directly to A in exchange for A stock and then distributed the A stock to P in complete liquidation. The transaction, as recharacterized, should qualify as a tax-free acquisitive D reorganization. *See* P.L.R. 200445016 (Jul. 20, 2004); *see also* Rev. Rul. 2004-83 (taxable sale of subsidiary stock to another subsidiary followed by an actual liquidation treated as a D reorganization); P.L.R. 200430025 (Apr. 2, 2004) (transfer of stock followed by a QSub election treated as a D reorganization).

Note that, as a result of the AJCA, section 357(c) no longer applies when T's liabilities exceed T's aggregate basis in its assets as long as the D reorganization is acquisitive. *See* section 357(c)(1)(B).

F Reorganization

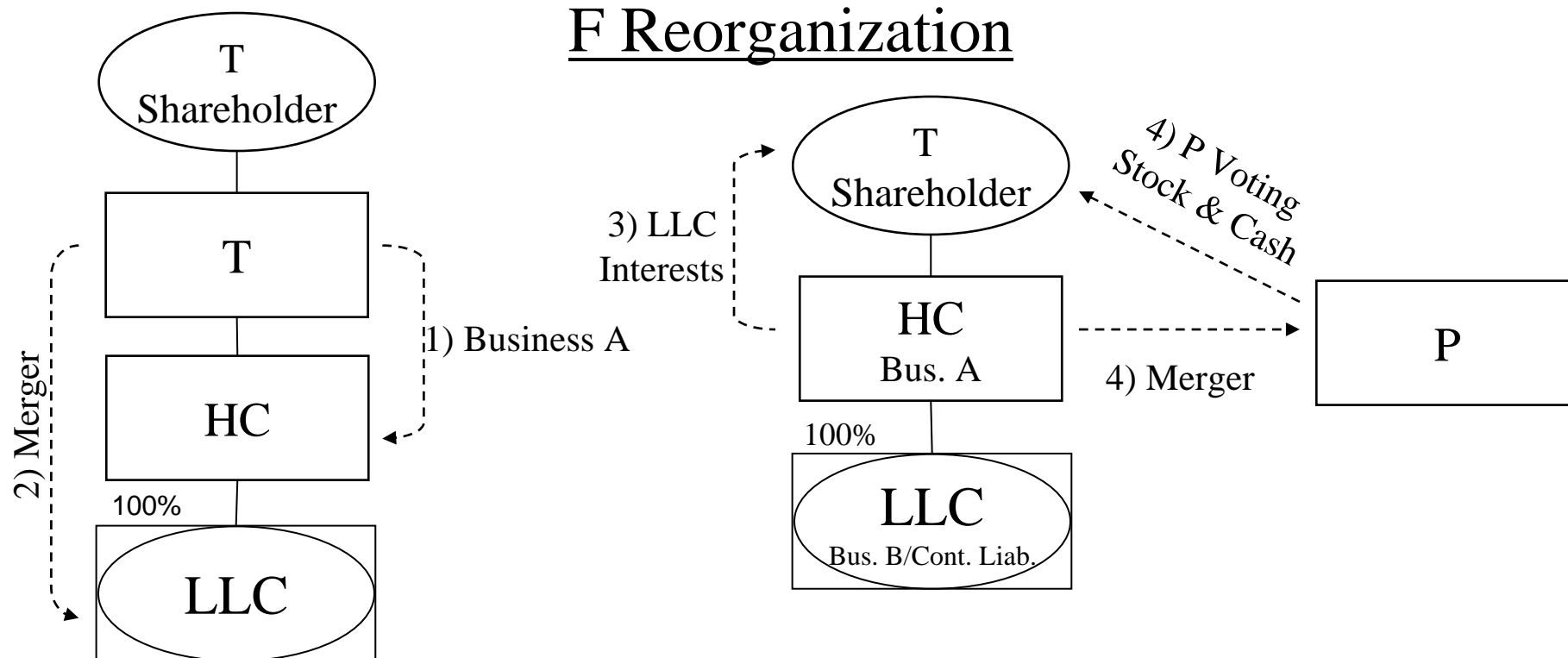

Facts: T conducts two businesses, Business A and Business B. P would like to acquire Business A in a tax-free reorganization in exchange for 80% P stock and 20% cash. T has contingent liabilities that P wants to leave behind. Further, assume for simplicity that the Business B assets have little or no built-in gain and T has a single shareholder. Accordingly, T forms a new corporation, HC, which in turn forms a wholly owned LLC treated as a disregarded entity. T transfers Business A to HC and then merges into LLC. HC then distributes the LLC interests to its shareholder in a taxable distribution. HC then merges into P, with the T shareholder receiving P stock and cash.

Result: Steps 1 and 2 should qualify as a tax-free F reorganization; step 3 should be treated as a taxable distribution of LLC's assets to T's shareholder; step 4 should qualify as a tax-free A reorganization. *See* Prop. Reg. § 1.368-2(m)(3)(ii); Rev. Rul. 96-29; PLRs 199902004, 199939017. What if, instead of a merger, the T shareholder sells the HC stock to P? *See* Prop. Reg. § 1.368-2(m)(2).

Merger Into LLC

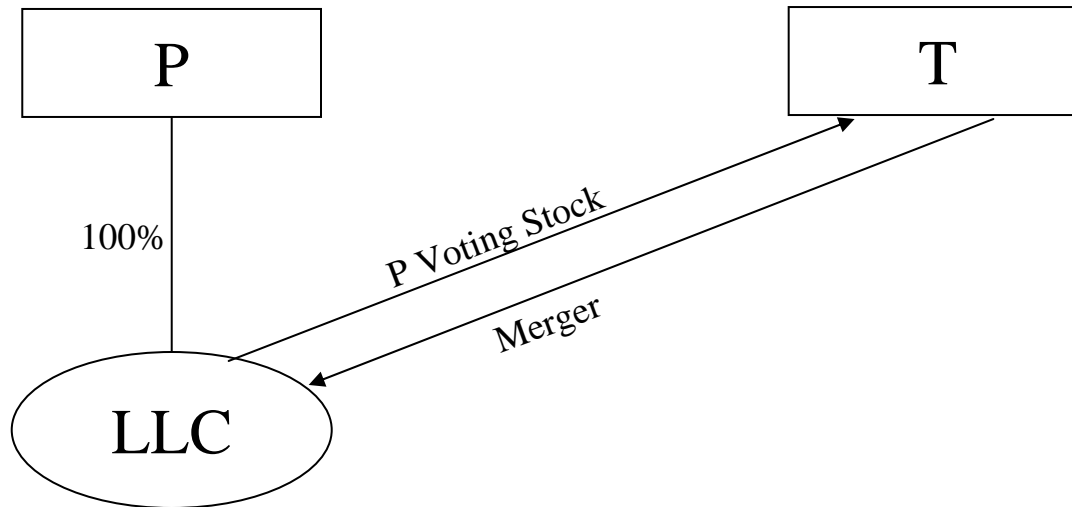

Facts: P forms a wholly owned LLC. LLC is treated as a disregarded entity. T merges into LLC pursuant to a state statutory merger, with the T shareholders receiving P voting stock. See Former Prop. Treas. Reg. § 1.368-2(b)(1).

Merger Into LLC - Alternative 1

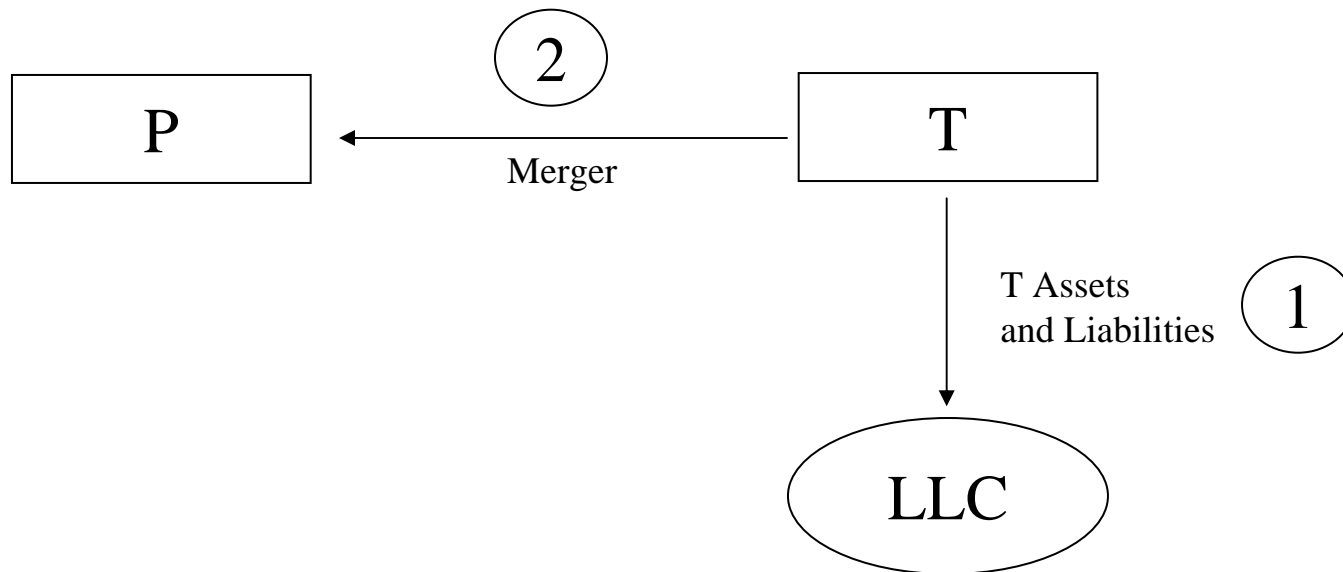

Facts: T forms a wholly owned LLC and contributes all of its assets and liabilities to LLC. LLC is treated as a disregarded entity. T then merges into P, with the T shareholders receiving P voting stock.

Merger Into LLC - Alternative 2

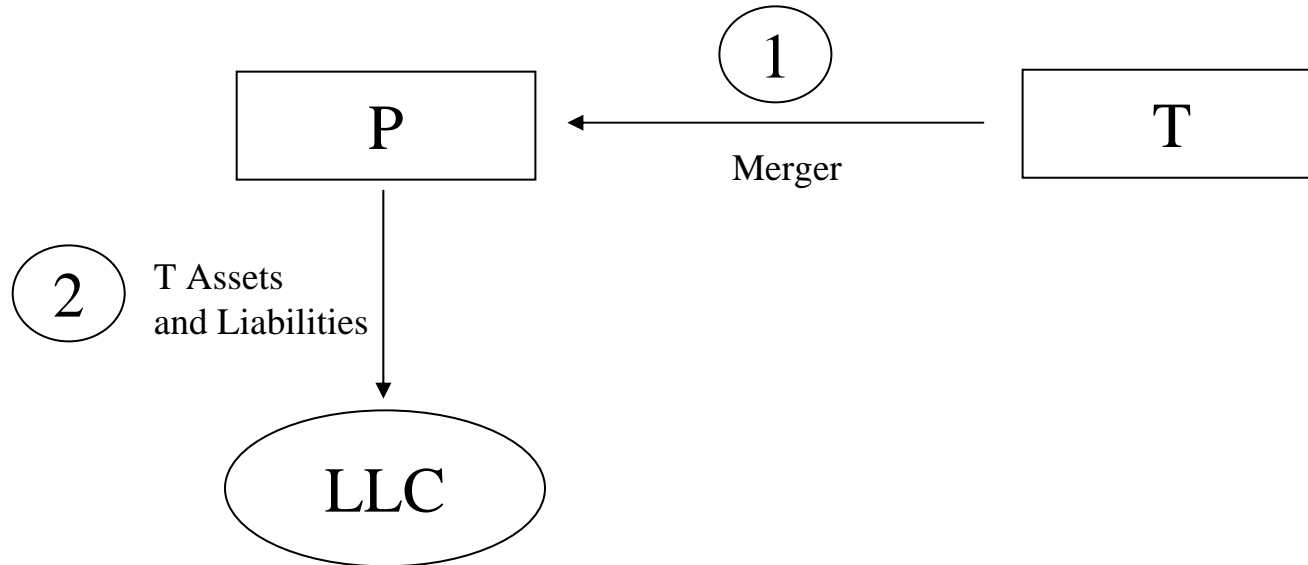

Facts: T merges into P, with the T shareholders receiving P voting stock. P then forms a wholly owned LLC and contributes all of the T assets and liabilities to LLC. LLC is treated as a disregarded entity.

Merger Into LLC - Alternative 3

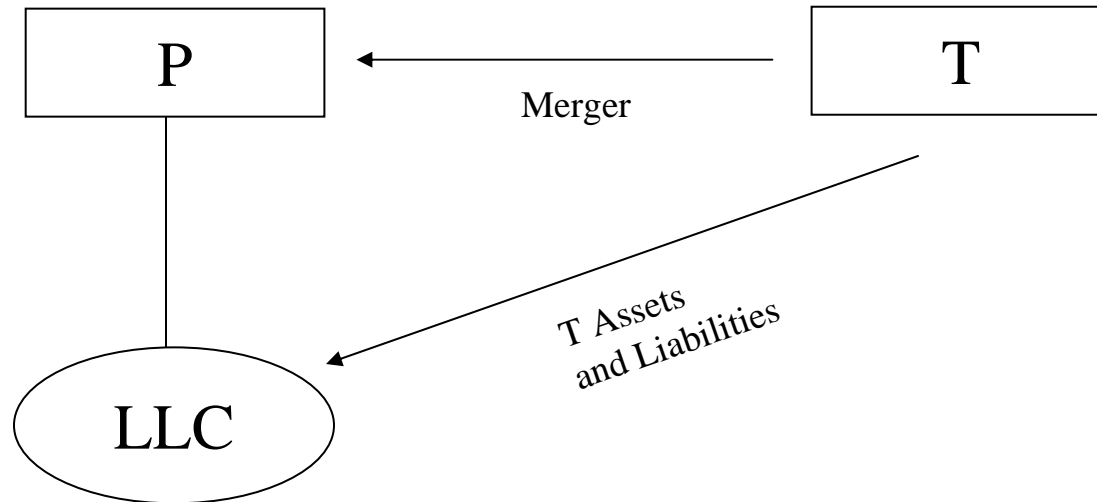

Facts: P forms a wholly owned LLC. LLC is treated as a disregarded entity. T merges into P, with the T shareholders receiving P voting stock. P directs that all of T's assets and liabilities be transferred directly to LLC.

Merger Into LLC - Alternative 4

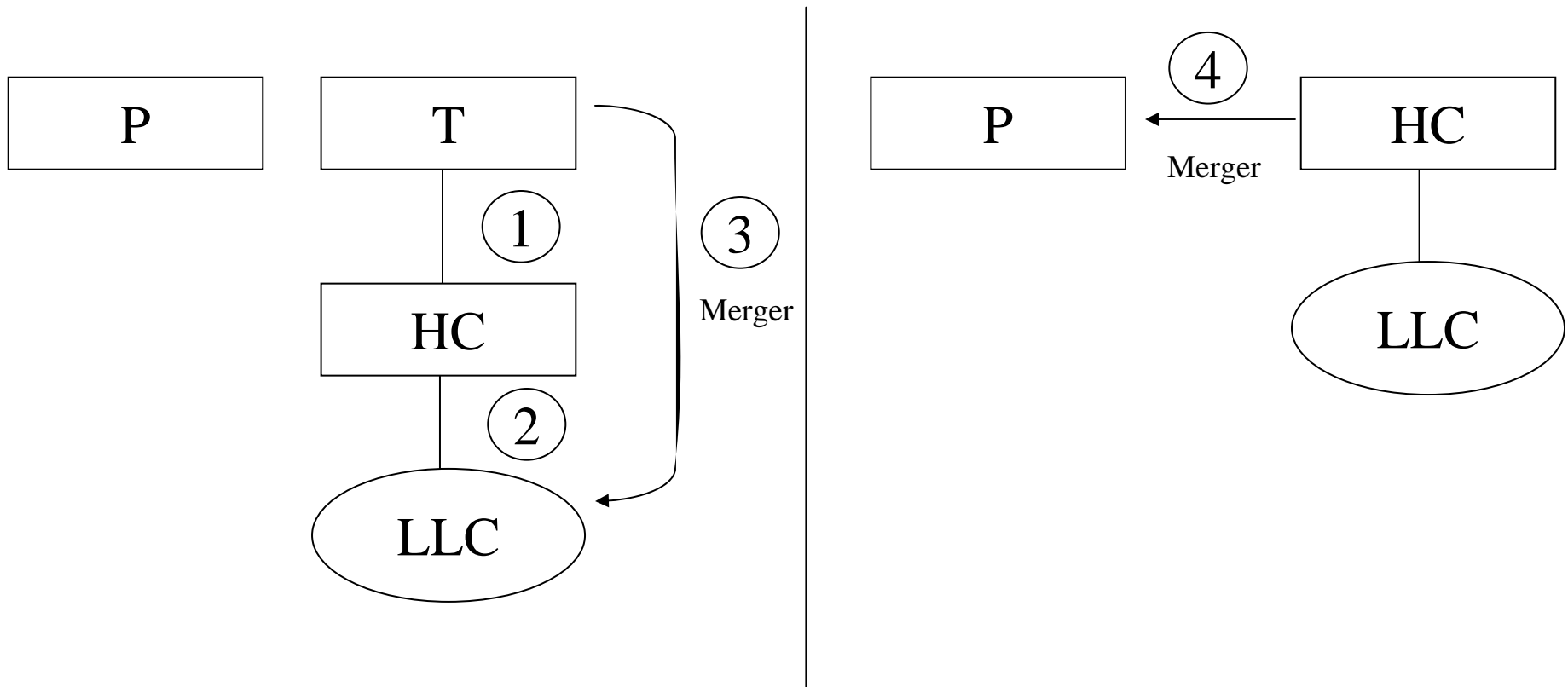

Facts: T forms a wholly owned subsidiary, HC, and HC forms a wholly owned LLC. LLC is treated as a disregarded entity. T merges into LLC, with the T shareholders receiving HC stock. HC then merges into P, with the HC shareholders receiving P voting stock.

LLC Merger Into Corporation

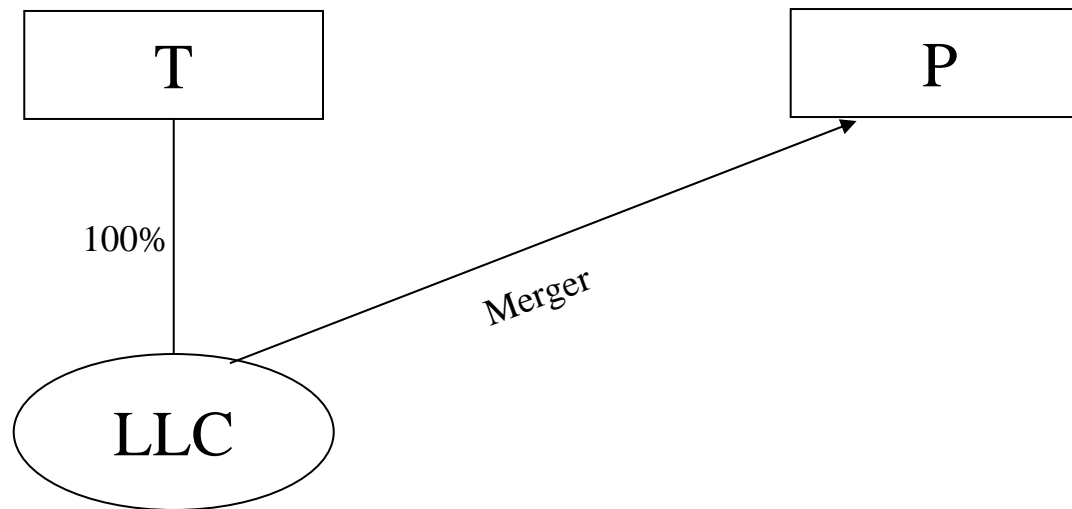

Facts: T owns all of the interests of LLC. LLC is treated as a disregarded entity. LLC operates a business. LLC merges into P pursuant to a state statutory merger. See Former Prop. Treas. Reg. § 1.368-2(b)(1).

Final Regulations on Statutory Mergers or Consolidations under Section 368

- On January 23, 2006, the IRS and Treasury issued final regulations defining the term “statutory merger or consolidation” as that term is used in the definition of an “A” reorganization under section 368(a)(1)(A) of the Code. These final regulations were the result of several iterations of proposed and temporary regulations and modifications made in response to comments.
 - The 2000 proposed regulations (May 16, 2000) provided that neither the merger of a disregarded entity into a corporation nor the merger of a target corporation into a disregarded entity could qualify as an A reorganization.
 - On November 15, 2001, the IRS and Treasury withdrew the 2000 proposed regulations and issued new proposed regulations that permitted certain statutory mergers involving disregarded entities to qualify as A reorganizations, if all of the assets and liabilities of the target are transferred to the acquiror and the target goes out of existence.
 - On January 24, 2003, the IRS and Treasury made certain minor clarifications to the proposed regulations and issued them as temporary regulations.
 - On January 5, 2005, the IRS and Treasury issued proposed regulations that would expand the temporary regulations to include mergers involving foreign entities and mergers effected pursuant to foreign laws within the scope of “statutory merger or consolidation.”

Final Section 368 Regulations

Definition of Terms

- A “statutory merger or consolidation” is defined as a transaction effected pursuant to the statute or statutes necessary to effect the merger or consolidation, in which transaction, as a result of the operation of such statute or statutes, the following events occur simultaneously at the effective time of the transaction in which:
 - All of the assets (other than those distributed in the transaction) and liabilities (except to the extent such liabilities are satisfied or discharged in the transaction or are nonrecourse liabilities to which assets distributed in the transaction are subject) of each member of one or more combining units (each a transferor unit) become the assets and liabilities of one or more members of one other combining unit (transferee unit), and
 - The combining entity of each transferor unit ceases its separate legal existence for all purposes.
 - This requirement will be satisfied even if, under applicable law, after the effective time of the transaction, the combining entity of the transferor unit (or its officers, directors, or agents) may act or be acted against, or a member of the transferee unit (or its officers, directors, or agents) may act or be acted against in the name of the combining entity of the transferor unit, provided that such actions relate to assets or obligations of the combining entity of the transferor unit that arose, or relate to activities engaged in by such entity, prior to the effective time of the transaction, and such actions are not inconsistent with the combination requirement above.
- The final regulations adopt the change in the proposed regulations to permit mergers or consolidations involving foreign entities and mergers or consolidations pursuant to foreign laws.

Final Section 368 Regulations

Definition of Terms

- The following terms are defined in the final regulations for purposes of defining statutory merger or consolidation:
 - Disregarded entity - Business entity (as defined in Treas. Reg. § 301.7701-2(a)) that is disregarded as an entity separate from its owner for federal income tax purposes. Examples include domestic single-member LLCs that do not elect to be treated as corporations, qualified REIT subsidiaries, and qualified subchapter S subsidiaries.
 - Combining entity - Business entity that is a corporation that is not a disregarded entity.
 - Combining unit - Comprised solely of a combining entity and all disregarded entities, if any, owned by the combining entity.

Final Section 368 Regulations

Merger of Target into Disregarded Entity

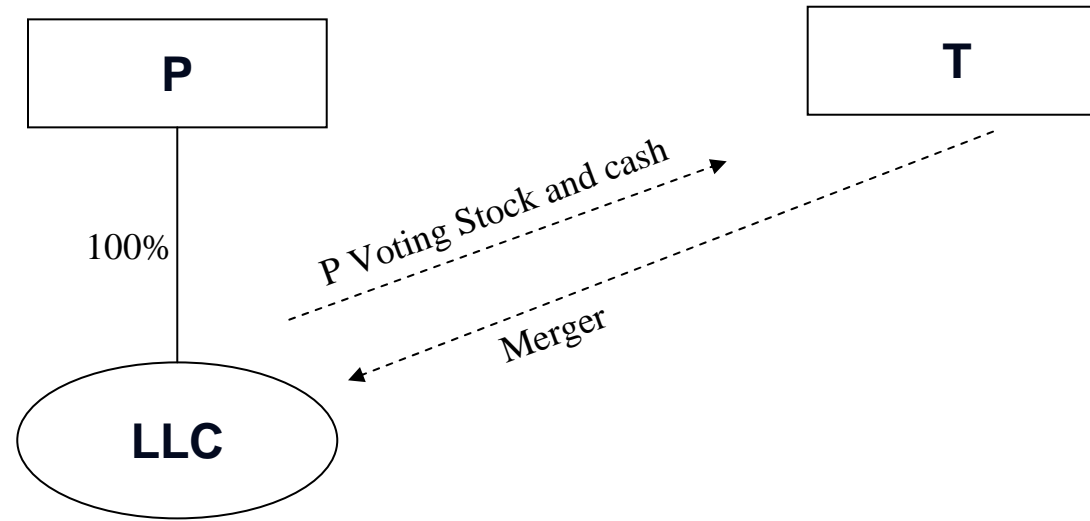

Facts: P and T are domestic corporations and LLC is a domestic limited liability company. LLC is wholly owned by P. LLC is treated as a disregarded entity. P and T are combining entities. P and LLC comprise a combining unit, and T is a combining unit. T merges into LLC under state statutory merger law, with the T shareholders receiving consideration of 50% P voting stock and 50% cash.

Result: The transaction qualifies as a tax-free A reorganization under Treas. Reg. § 1.368-2(b)(1)(ii). See Treas. Reg. § 1.368-2(b)(1)(iii), ex. 2.

Final Section 368 Regulations

Merger of Disregarded Entity into Corporation

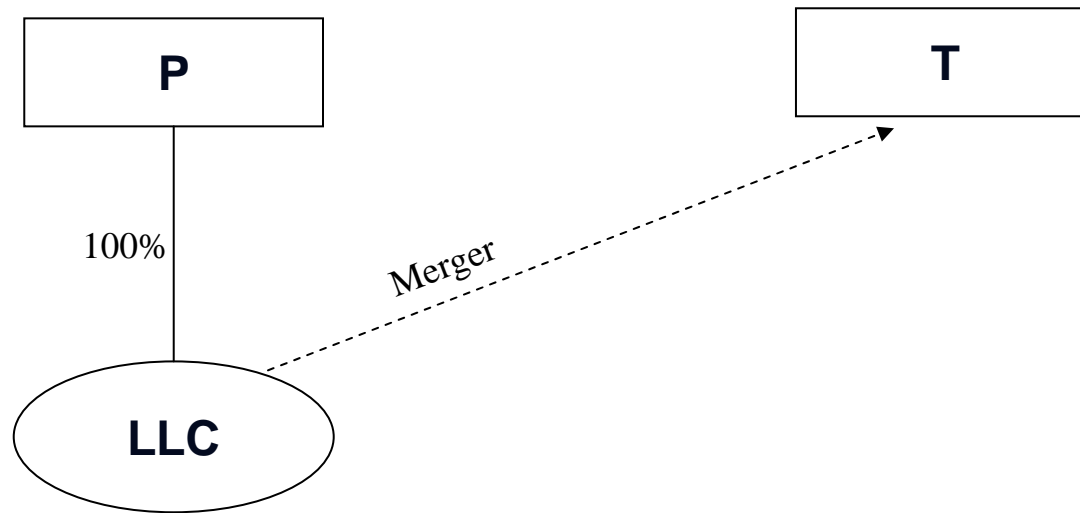

Facts: P and T are domestic corporations and LLC is a domestic limited liability company. LLC is wholly owned by P. LLC is treated as a disregarded entity. P and LLC comprise a combining unit, and T is a combining entity and combining unit. LLC merges into T under state statutory merger law with shareholders of T receiving P stock and cash.

Result: The transaction does not qualify as a tax-free A reorganization under Treas. Reg. § 1.368-2(b)(1)(ii) because all of assets and liabilities of the combining unit of P and LLC do not become assets of T, and LLC is not a combining entity. See Treas. Reg. § 1.368-2(b)(1)(iii), ex. 6.

Notes: If LLC is a transitory merger subsidiary, is a recast under Rev. Rul. 67-448 available if only P shares are used?

If LLC is not a transitory merger subsidiary, could the transaction be viewed as a section 351 transaction to the extent of the LLC assets (and possibly a “B” reorganization with respect to the rest)?

Final Section 368 Regulations

Merger of Target and LLC into Separate D.E.s

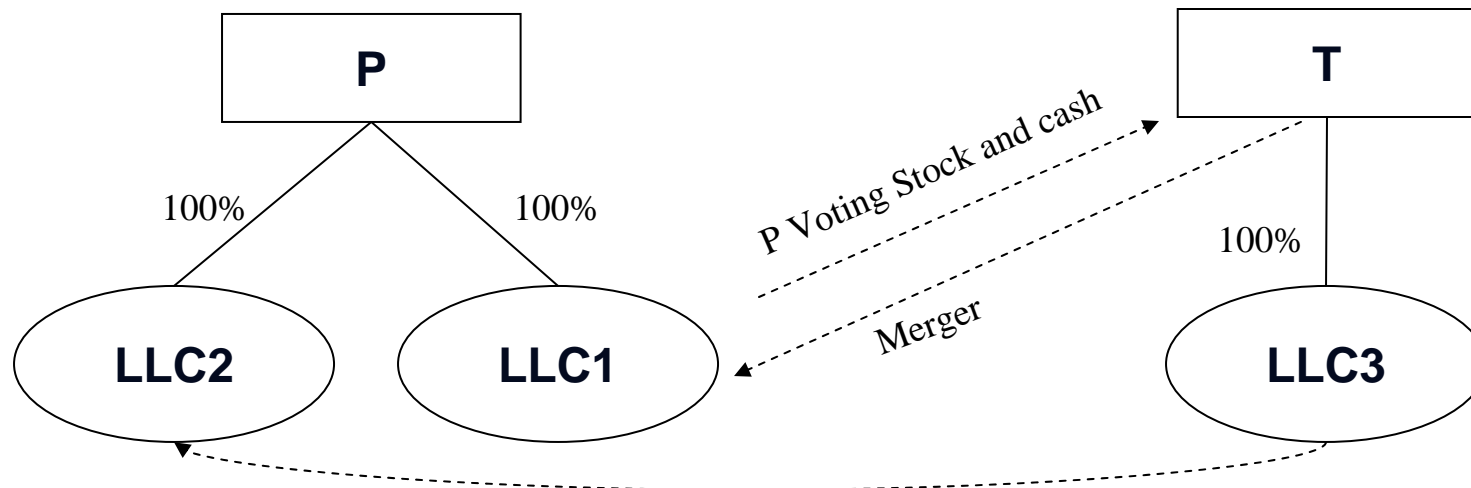

Facts: P and T are domestic corporations and LLC₁, LLC₂, and LLC₃ are domestic limited liability companies. LLC₁ and LLC₂ are wholly owned by P. LLC₃ is wholly owned by T. The LLCs are treated as disregarded entities. P, LLC₁, and LLC₂ comprise a combining unit, and T and LLC₃ comprise a combining unit. T merges into LLC₁ under state statutory merger law, with the T shareholders receiving consideration consisting of 50% P voting stock and 50% cash. LLC₃ merges into LLC₂ under state statutory merger law.

Result: The transaction qualifies as a tax-free A reorganization under Treas. Reg. § 1.368-2(b)(1)(ii). See Treas. Reg. § 1.368-2(b)(1)(iii), ex. 2.

Final Section 368 Regulations

Merger of Foreign Entities Under Foreign Law

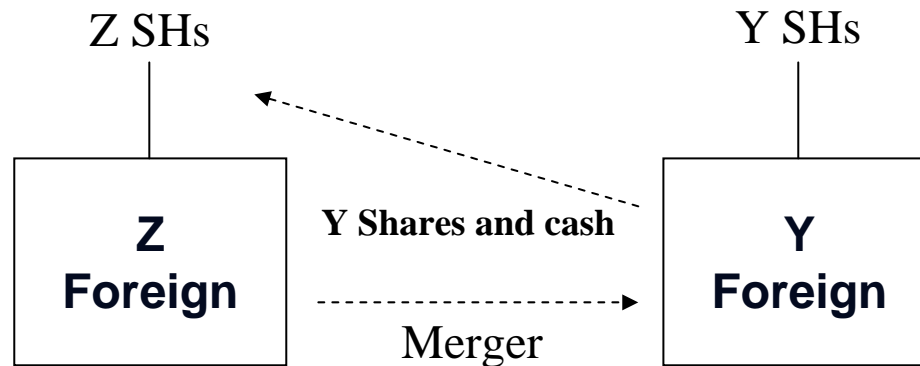

Facts: Z and Y are entities organized under the laws of Country Q and classified as corporations for Federal tax purposes. Z merges into Y under Country Q law. Pursuant to statutes of Country Q the following events occur simultaneously: (i) all of the assets and liabilities of Z become the assets and liabilities of Y, (ii) Z's separate legal existence ceases for all purposes, and (iii) Z shareholders receive consideration consisting of 50% Y voting stock and 50% cash.

Result: Under the final regulations, this transaction qualifies as an "A" reorganization. See Treas. Reg. §§ 1.368-2(b)(1)(ii), -2(b)(1)(iii) Ex. 13.

Final Section 368 Regulations

Mergers Involving Foreign Disregarded Entities

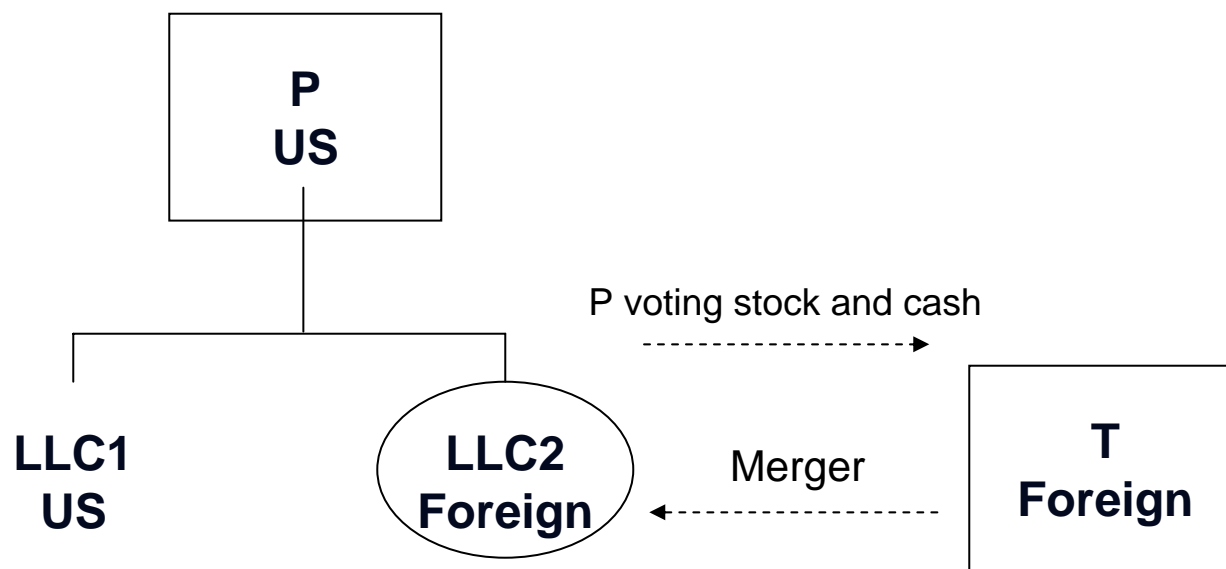

Facts: P owns 100% of the outstanding units of LLC₁ and LLC₂. Both LLCs are treated as disregarded entities for Federal tax purposes. LLC₂ and T are entities organized under the laws of Country Q. P and its LLCs comprise a combining unit. T is a combining entity and combining unit. Pursuant to Country Q law, T merges with and into LLC₂ with T shareholders exchanging their T stock for 50% P voting stock and 50% cash.

Result: This transaction should qualify as an “A” reorganization under Treas. Reg. § 1.368-2(b)(1)(ii).

Final Section 368 Regulations

State Law Consolidation

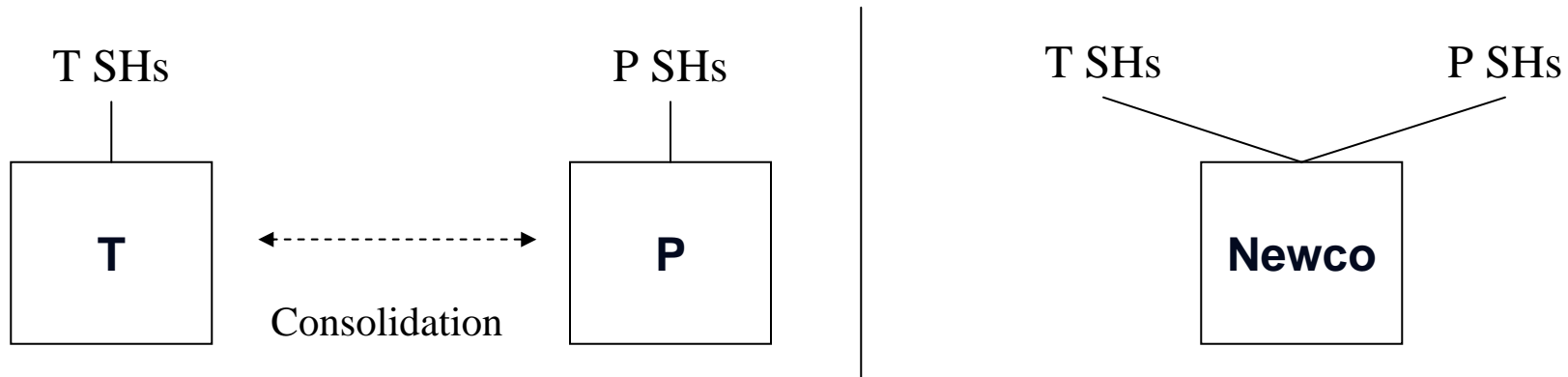

Facts: Under state W law, T and P consolidate. Pursuant to such law, the following events occur at the effective time of the transaction: all of the assets and liabilities of T and P become the assets and liabilities of Newco, an entity that is created in the transaction, and the existence of T and P continues in Newco. In the consolidation, the T and P shareholders exchange their stock of T and P, respectively, for stock of Newco.

Result: Under the final regulations, the consolidation qualifies as an “A” reorganization, because it is a transaction effected pursuant to the statute or statutes necessary to effect the merger or consolidation (i.e., State W consolidation law), all of the assets and liabilities of each member of one or more combining units (i.e., P and T) become the assets and liabilities of one or more members of another combining unit (i.e., Newco). See Treas. Reg. § 1.368-2(b)(1)(ii). The fact that the existence of the consolidating corporations (T and P) continues in Newco under State W law will not prevent the consolidation from qualifying as a statutory merger or consolidation. See Preamble to Treas. Reg. § 1.368-2(b); Treas. Reg. § 1.368-2(b)(1)(iii), Ex. 12.

Final Section 368 Regulations

State Law Consolidation = “F” followed by “A”?

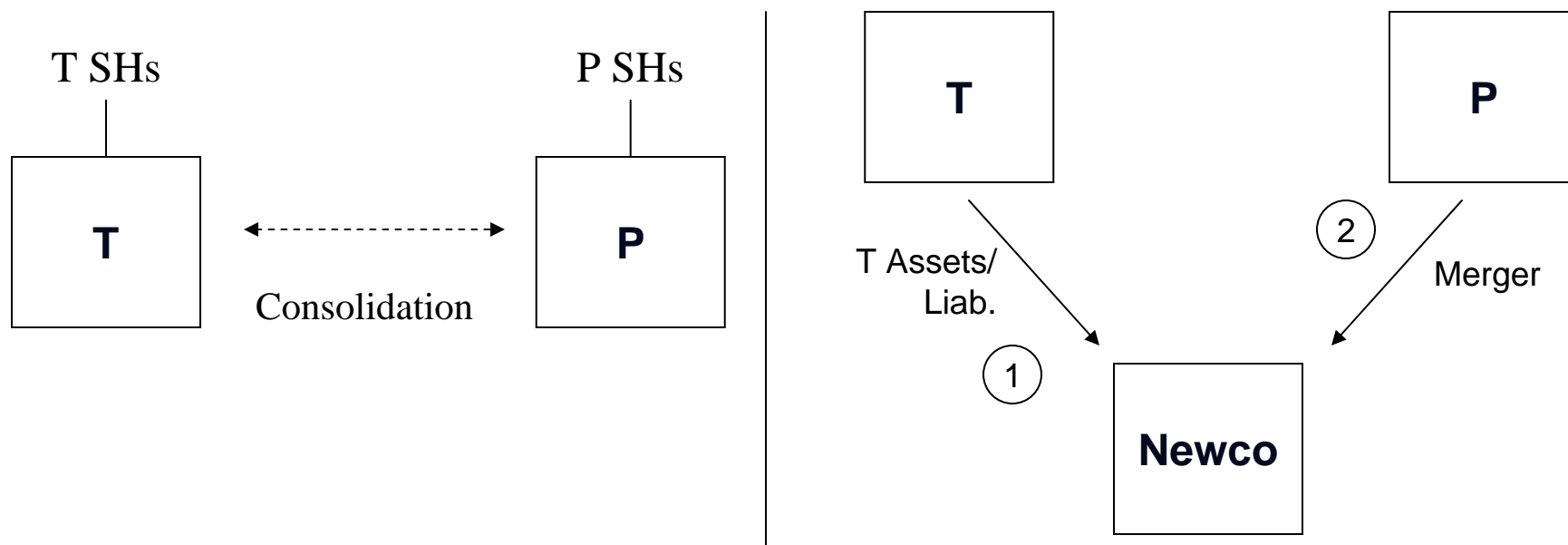

Facts: T and P are state W corporations with operating businesses. Under state W law, T and P consolidate. Pursuant to such law, the following events occur at the effective time of the transaction: all of the assets and liabilities of T and P become the assets and liabilities of Newco, an entity that is created in the transaction, and the existence of T and P continues in Newco. In the consolidation, the T and P shareholders exchange their stock of T and P, respectively, for stock of Newco.

Result: Under the final regulations, the consolidation qualifies as an “A” reorganization. Treas. Reg. § 1.368-2(b)(1)(iii), Ex. 12. However, the IRS and Treasury intend to study whether this consolidation could be treated as an “F” reorganization of T into Newco immediately followed by a merger of P into Newco in an “A” reorganization. See Preamble to Treas. Reg. § 1.368-2(b).

Final Section 368 Regulations

Amalgamation Under Foreign Law

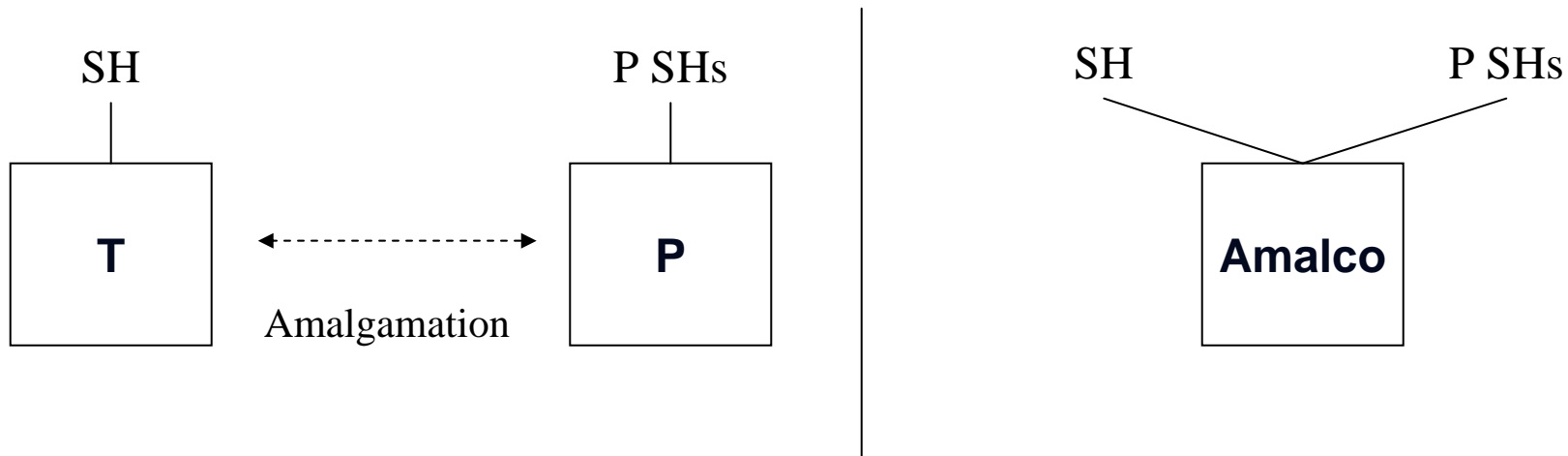

Facts: T, a Country Q Limited Company with a single US shareholder (SH), amalgamates with P, also a Country Q Limited Company, pursuant to the law of Country Q. By operation of law, the assets of T and P become assets of a new entity (“Amalco”), P and T cease their separate existence, and SH and the P shareholders receive shares of Amalco stock as consideration. SH receives 30% of Amalco’s outstanding shares.

Result: Under the final regulations, the amalgamation qualifies as an “A” reorganization, because it is a transaction effected pursuant to the statute or statutes necessary to effect the merger or consolidation (i.e., Country Q amalgamation law), all of the assets and liabilities of each member of one or more combining units (i.e., P and T) become the assets and liabilities of one or more members of another combining unit (i.e., Amalco). See Treas. Reg. § 1.368-2(b). The fact that the existence of the amalgamating corporations (T and P) continues in Amalco under Country Q law will not prevent the amalgamation from qualifying under the final regulations as a statutory merger or consolidation. See Preamble to Treas. Reg. § 1.368-2(b); Treas. Reg. § 1.368-2(b)(1)(iii), Ex. 14.

Final Section 368 Regulations

Foreign Law Amalgamation Using Parent Stock

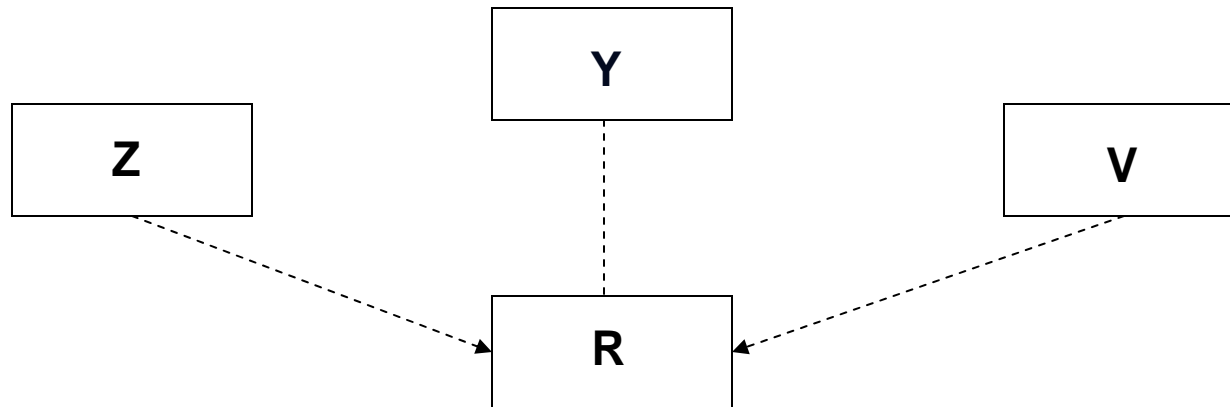

Facts: Z and V are entities organized under the laws of Country Q and classified as corporations for Federal income tax purposes. Y seeks to acquire Z and V. Z and V amalgamate. Pursuant to statutes of Country Q, the following events occur simultaneously: all the assets and liabilities of Z and V become the assets and liabilities of R, an entity that is created in the transaction and that is wholly owned by Y immediately after the transaction, and Z's and V's separate legal existences cease for all purposes. In the transaction, the Z and V shareholders exchange their Z and V stock, respectively, for consideration consisting of 50% Y voting stock and 50% cash.

Result: With respect to each of Z and V, the transaction satisfies the requirements of a statutory merger or consolidation under Treas. Reg. § 1.368-2(b)(1)(ii), because the transaction is effected pursuant to Country Q law and the following events occur simultaneously at the effective time of the transaction: all of the assets and liabilities of Z and V, respectively, each of which is the combining entity of a transferor unit, become the assets and liabilities of R, the combining entity and sole member of the transferee unit, with regard to each of the above transfers, and Z and V each ceases its separate legal existence for all purposes. Because Y is in control of R immediately after the transaction, the Z shareholders and the V shareholders will be treated as receiving stock of a corporation that is in control of R, the combining entity of the transferee unit that is the acquiring corporation for purposes of section 368(a)(2)(D). Accordingly, the transaction qualifies as the statutory merger or consolidation of each of Z and V into R, a corporation controlled by Y, and is a reorganization under section 368(a)(1)(A) by reason of section 368(a)(2)(D). See Treas. Reg. § 1.368-2(b)(1)(iii) ex. 14. The Preamble to Treas. Reg. § 1.368-2(b)(1) provides that Y need not control R immediately before the transaction in order to meet the requirements of section 368(a)(2)(D).

Final Section 368 Regulations

Foreign Law Amalgamation Using Parent Stock

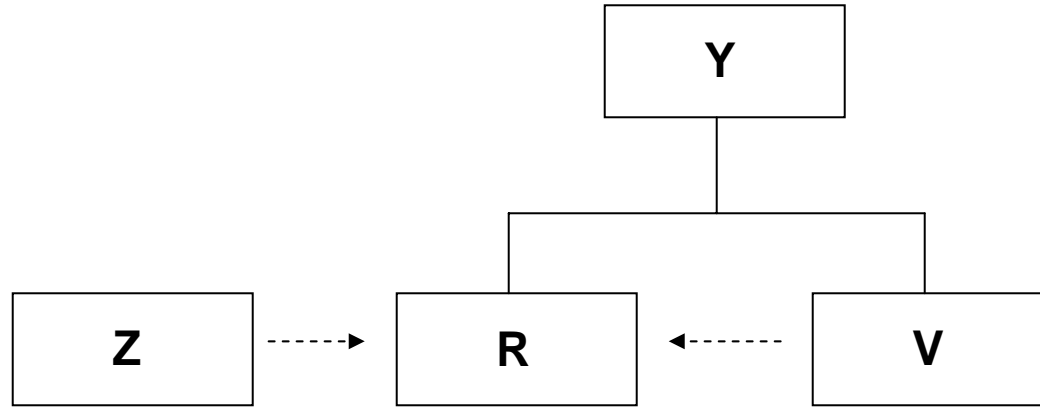

Facts: V is a wholly owned subsidiary of Y; Z and V amalgamate under foreign law. The shareholders of Z receive shares of Y in the transaction.

Analysis: The preamble to the final regulations states, “The IRS and Treasury Department believe that a triangular consolidation or amalgamation should be tested under the reorganization rules as a forward triangular merger of each of the consolidating or amalgamating corporations into a wholly-owned subsidiary of the parent corporation.” Under the final regulations, the transaction is treated as a reorganization under sections 368(a)(1)(A) and (a)(2)(D) with respect to Z.

Is the transaction also treated as a reorganization under sections 368(a)(1)(A) and (a)(2)(D) with respect to V? Could the transaction instead be treated a “D” reorganization with respect to V and an (a)(2)(D) with respect to Z?

What is the impact on Rev. Rul. 84-104 (treating a triangular state law consolidation as a reorganization under sections 368(a)(1)(A) and (a)(2)(E))? Is treatment as a forward triangular merger applicable only where both amalgamating companies are old and cold operating companies?

Final Section 368 Regulations

Foreign Law Amalgamation Using Parent Stock

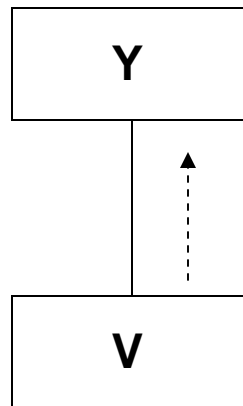

Facts: V is a wholly owned subsidiary of Y; V and Y amalgamate under foreign law.

Analysis: How is an amalgamation treated in the parent subsidiary context ? Is this transaction treated as a section 332 liquidation? See, e.g., PLR 9349020; PLR 9111006; PLR 8135086. Does the treatment of an amalgamation as a merger of each amalgamating company in the triangular amalgamation context have any effect on the parent-subsidary context?

Final Section 368 Regulations

Merger of Corporation into D.E. in Exchange for Interests in the D.E.

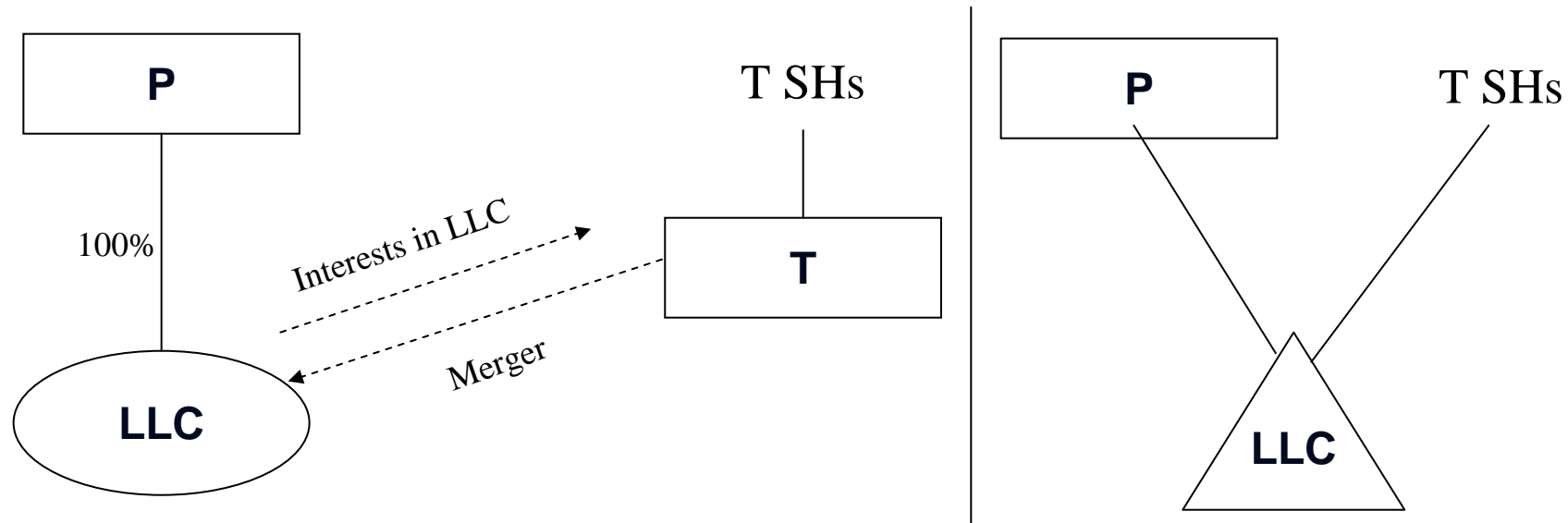

Facts: P and T are domestic corporations and LLC is a domestic limited liability company. LLC is wholly owned by P. LLC is treated as a disregarded entity. T merges into LLC under state statutory merger law, with the T shareholders receiving interests in LLC. After merger, LLC is not disregarded as an entity separate from P and is treated as a partnership for federal income tax purposes.

Result: The transaction does not qualify as a tax-free A reorganization because assets of T do not become assets of a combining unit. LLC cannot be a combining entity as a partnership and, thus, is not part of a combining unit. See Treas. Reg. § 1.368-2(b)(1)(iii), ex. 7.

Note: What if LLC elects to be taxed as a corporation effective at the time of the merger? See Rev. Rul. 76-123, 1976-1 C.B. 94; Rev. Rul. 68-349, 1968-2 C.B. 143; Rev. Rul. 68-357, 1968-2 C.B. 144.

Final Section 368 Regulations

Merger of Corporate Partner Into a Partnership

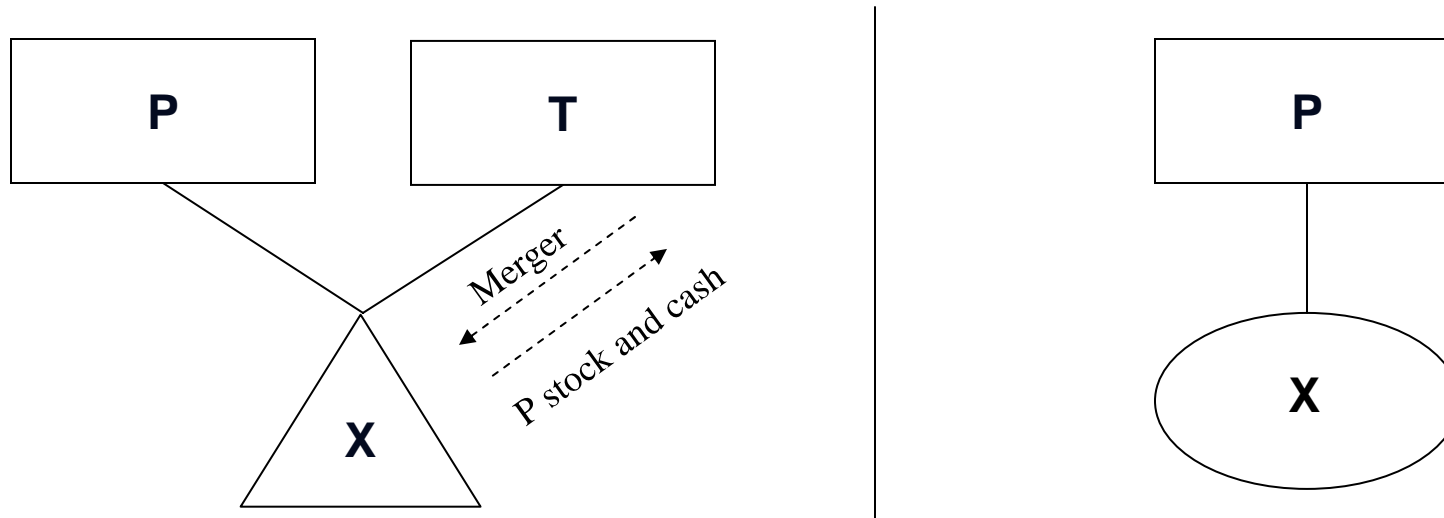

Facts: P and T, both corporations, together own all of the membership interests in X, a limited liability company that is treated as a partnership for federal income tax purposes. Under State W law, T merges into X. Pursuant to such law, the following events occur simultaneously at the time of the transaction: all of the assets and liabilities of T become the assets and liabilities of X, and T ceases its separate legal existence for all purposes. In the merger, the shareholders of T exchange their T stock for consideration consisting of 50% P stock and 50% cash. As a result of the merger, X becomes an entity that is disregarded as an entity separate from P.

Result: Under the final regulations, the transaction satisfies the requirements of a statutory merger or consolidation because the transaction is effected pursuant to State W law and the following events occur simultaneously at the effective time of the transaction: all of the assets and liabilities of T, the combining entity and sole member of the transferor unit, become the assets and liabilities of one or more members of the transferee unit that is comprised of P, the combining entity of the transferee unit, and X, a disregarded entity the assets of which P is treated as owning for tax purposes immediately after the transaction, and T ceases its separate legal existence for all purposes. See Treas. Reg. § 1.368-2(b)(1)(iii), ex. 11. The existence and composition of the transferee unit are determined immediately after (but not immediately before) the merger. See Preamble to Treas. Reg. § 1.368-2(b)(1).

Final Section 368 Regulations

Merger of Corporate Partner Into a Partnership (cont.)

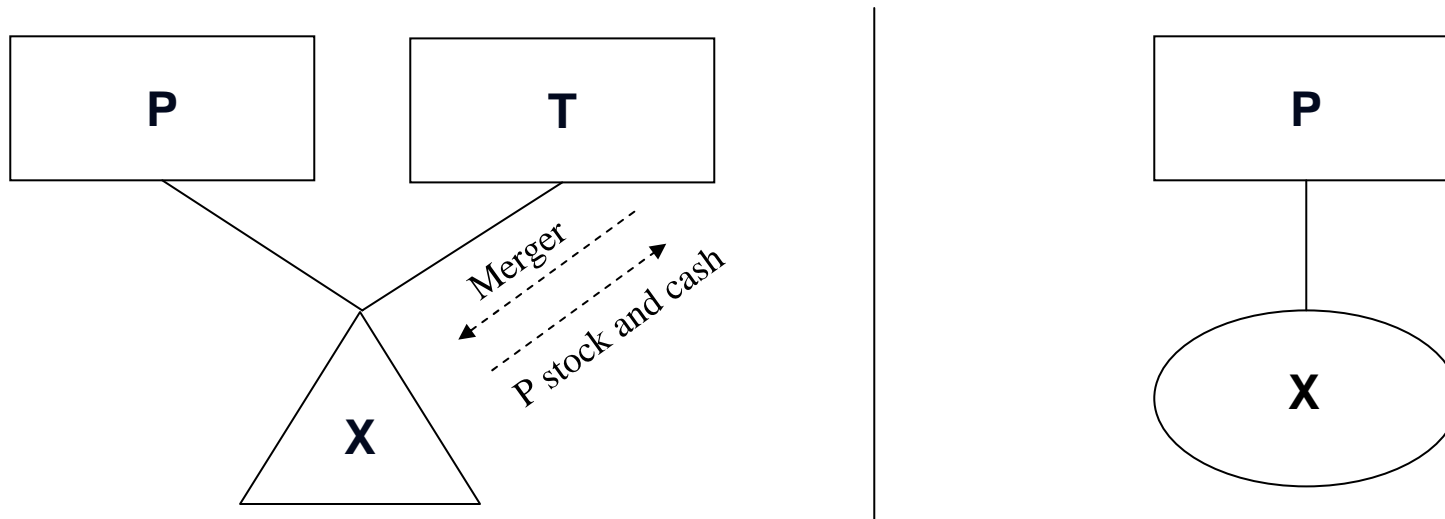

Issues: In this transaction, X terminates as a partnership under section 708(b)(1)(A). The preamble to Treas. Reg. § 1.368-2(b)(1) notes that this transaction “raises questions as to the tax consequences of the transaction to the parties, including whether gain or loss may be recognized under the partnership rules...as a result of the termination of” X. The preamble also inquires whether the principles of Rev. Rul. 99-6 should apply to this transaction.

Final Section 368 Regulations

Merger of Corporate Partner Into a Partnership

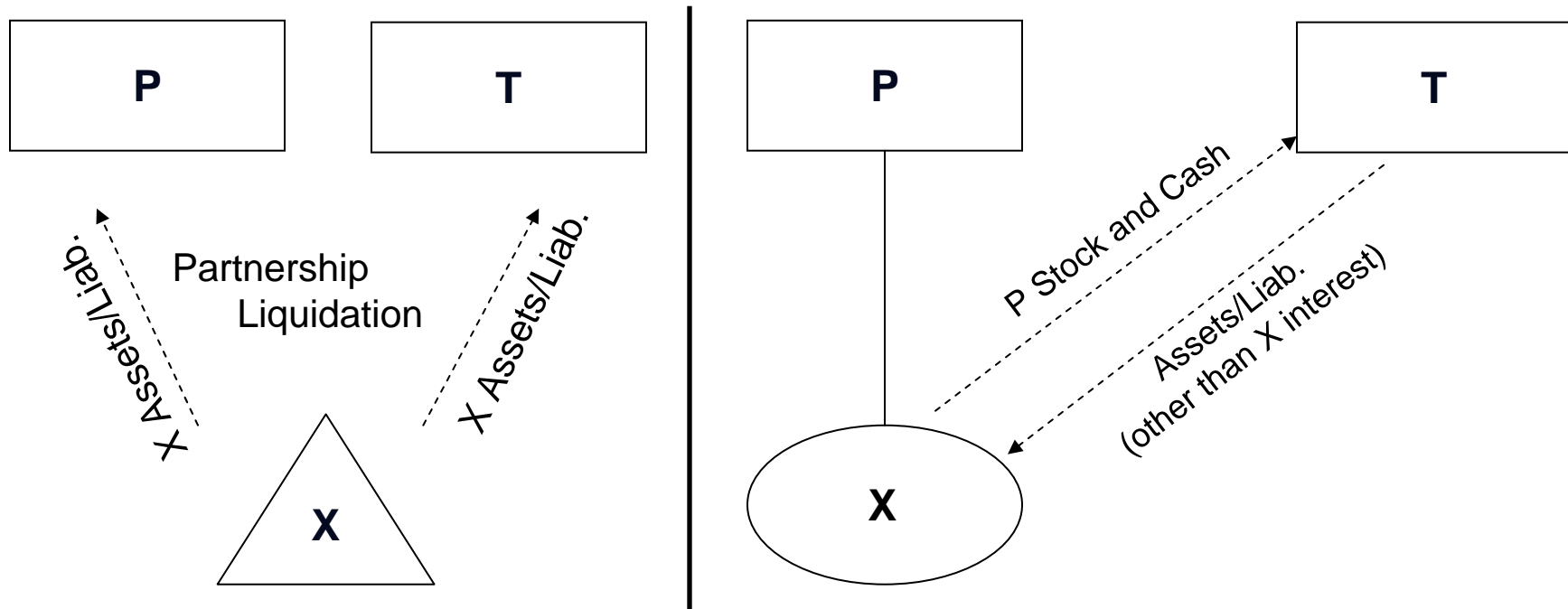

Issues: In this transaction, X terminates as a partnership under section 708(b)(1)(A). The preamble to Treas. Reg. § 1.368-2(b)(1) notes that this transaction “raises questions as to the tax consequences of the transaction to the parties, including whether gain or loss may be recognized under the partnership rules...as a result of the termination of” X. The preamble also inquires whether the principles of Rev. Rul. 99-6 should apply to this transaction.

Possible Approach: In order to read the Code as a whole (i.e., avoiding subchapter C rules from completely overriding subchapter K rules), the following deemed transactions could be viewed as occurring: (i) X liquidates by distributing its assets pro rata to P and T under the rules of subchapter K, and (ii) T transfers all of its remaining assets and liabilities to X (now a disregarded entity) in a qualifying A reorganization.

Final Section 368 Regulations

Merger of Corporate Partner Into Other Partner

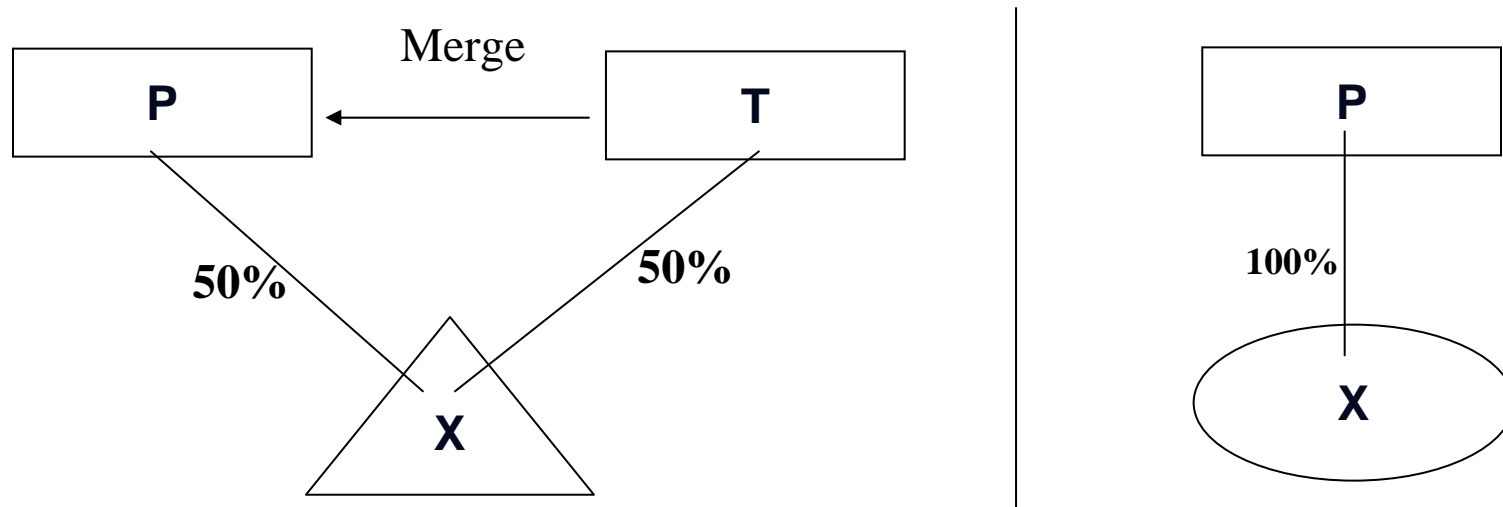

Facts: P and T each own a 50% interest in X. T merges into P in an “A” reorganization. Afterward, P is the sole owner of X, which is disregarded as an entity separate from P.

Results: The partnership terminates under section 708(b)(1)(A) when P acquires T’s interest in X by operation of law. Does Rev. Rul. 99-6 apply to this type of partnership termination? Rev. Rul. 99-6 involved a taxable sale of a partnership interest from T to P. All the authorities cited in Rev. Rul. 99-6 involve taxable sales of partnership interests. See Rev. Rul. 67-65; Rev. Rul. 55-68; McCauslen v. Comm’r, 45 T.C. 588. Accordingly, neither Rev. Rul. 99-6 nor McCauslen appear to apply to these facts. Does it matter? See sections 362(b), 735(b), 1223(2). Treasury and the IRS have requested comments on whether “the principles of Revenue Ruling 99-6” apply to these facts. T.D. 9242 (Jan. 23, 2006).

Final Section 368 Regulations

Step Transaction Issues

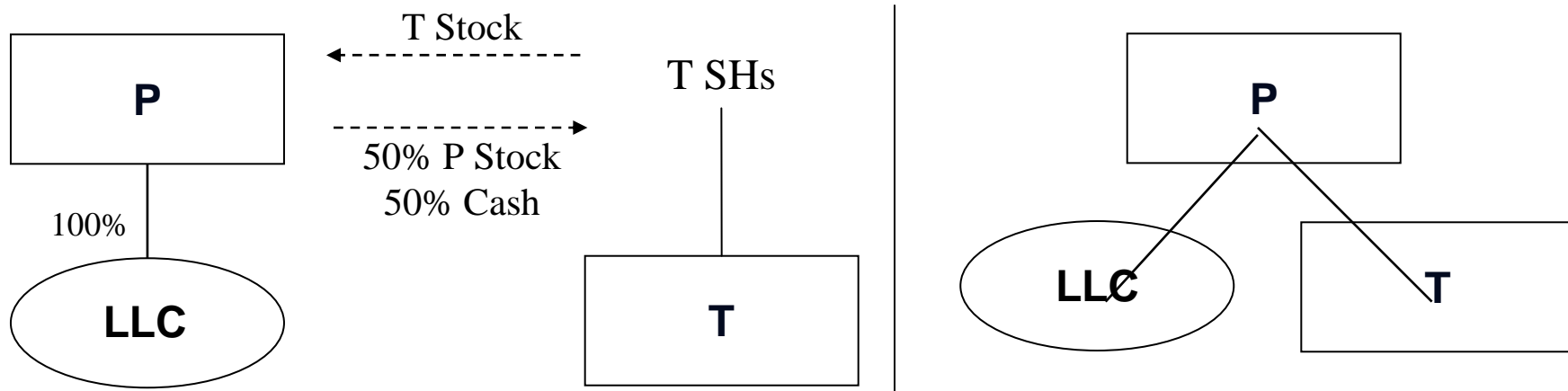

Facts: P and T are domestic corporations. P owns all of the interests in LLC, a domestic limited liability company that is disregarded for federal tax purposes. T's shareholders transfer their T stock to P in exchange for 50% P stock and 50% cash. Immediately after the acquisition, T engages in one of the following alternative transactions.

- (1) T merges into P = A reorganization
- (2) T merges into LLC = A reorganization
- (3) T files a form in Delaware to become an LLC = Not an A reorganization
- (4) T checks the box to be treated as a disregarded entity = Not an A reorganization
- (5) T liquidates into P = Not an A reorganization
- (6) T dissolves = Not an A reorganization if remaining property does not vest in parent upon dissolution

Does the form of the second step determine the characterization of the transaction? Under what circumstances could a state law liquidation be treated as a consolidation treated as an A reorganization?

See King Enterprises, Inc. v. United States, 418 F. 2d 511 (Ct. Cl. 1969); Rev. Rul. 67-274; Rev. Rul. 72-405; Rev. Rul. 2001-46, 2001-2 C.B. 321; Rev. Rul. 90-95, 1990-2 CB 67; P.L.R. 9539018 (June 30, 1995); Preamble to Treas. Reg. § 1.368-2(b)(1).

Final Section 368 Regulations

Revenue Ruling 69-617 Variation

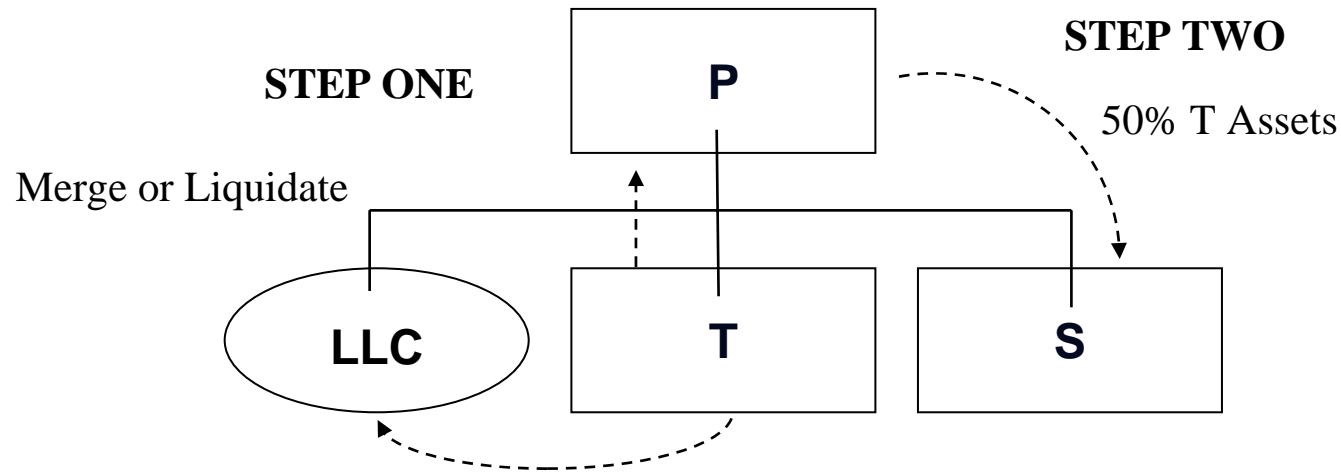

Facts: P, T, and S are domestic corporations. P owns all of the stock of T and S and all of the interests in LLC, a domestic limited liability company that is disregarded for federal tax purposes. T engages in one of the following alternative transactions and immediately thereafter, P contributes half of T's assets to S.

- (1) T merges into P = A reorganization
- (2) T merges into LLC = A reorganization
- (3) T files a form in Delaware to become an LLC = Not an A reorganization
- (4) T checks the box to be treated as a disregarded entity = Not an A reorganization
- (5) T liquidates into P = Not an A reorganization
- (6) T dissolves = Not an A reorganization if remaining property does not vest in parent upon dissolution.

See Rev. Rul. 69-617, 1969-2 CB 57; P.L.R. 9422057 (Mar. 11, 1994); P.L.R. 9222059 (Jun. 13, 1991); P.L.R. 8710067 (Dec. 10, 1986); Treas. Reg. § 1.368-2(d)(4); Preamble to Treas. Reg. § 1.368-2(b)(1).

Final Section 368 Regulations

Acquisition and Check-the-box Election

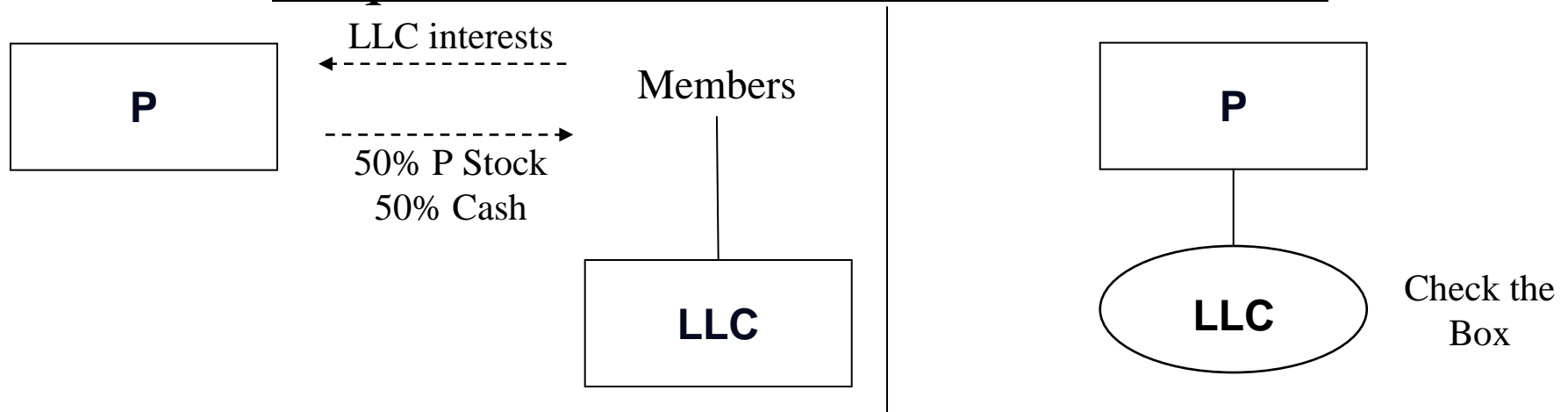

Facts: LLC is treated as a corporation for federal income tax purposes. P acquires the LLC interests from the LLC members in exchange for consideration that consists of 50% voting stock of P and 50% cash. Immediately after the acquisition, LLC checks the box to be treated as a disregarded entity. P’s acquisition of the LLC interests and the election to treat LLC as a disregarded entity are steps in a single integrated acquisition by P of the T assets.

Result: Under the final regulations, the acquisition by P of the assets of LLC does not satisfy the requirements of a statutory merger or consolidation for two reasons. First, LLC, the combining entity of the transferor unit, does not cease its separate legal existence. Although LLC is a disregarded entity, it continues to exist as a juridical entity after the conversion. Second, P does not assume the assets and liabilities of LLC pursuant to statute.

Notes: The IRS and Treasury are continuing to study whether an acquisition followed by an election to be treated as a disregarded entity should be permitted to qualify as a statutory merger or consolidation. However, pending further consideration, the final regulations clarify that such a transaction does not qualify. See Preamble to Treas. Reg. § 1.368-2(b).

Does Rev. Rul. 62-274 require this transaction to be tested as a “C” reorganization?

Does the answer change if the acquisition involves a forward merger of LLC into an existing subsidiary of P? See Rev. Rul. 72-405.

A merger into a pre-existing disregarded entity would be treated as an “A” reorganization. See Treas. Reg. § 1.368-2(b)(1)(iii) ex. 2. Should the analysis be different when a check-the-box election for LLC is made effective immediately after the merger, rather than immediately before?

Final Section 368 Regulations

Acquisition and State Law Conversion of Target into LLC

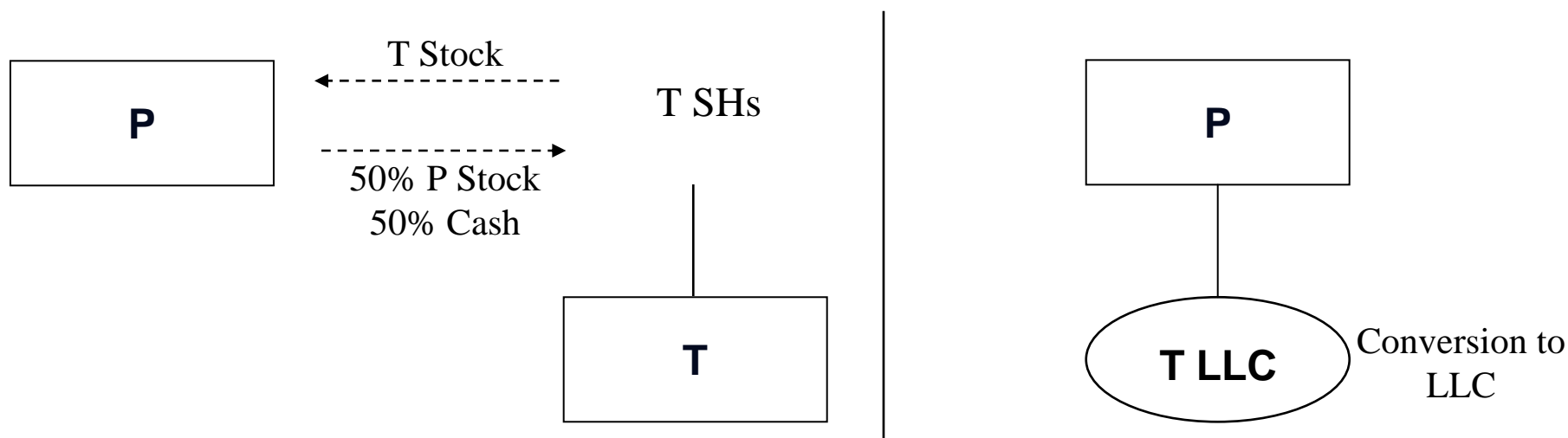

Facts: P acquires the stock of T from the T shareholders in exchange for consideration that consists of 50% voting stock of P and 50% cash. Immediately after the stock acquisition, T files the necessary documents to convert from a corporation to an LLC under State W law. P’s acquisition of the stock of T and the conversion of T to an LLC are steps in a single integrated acquisition by P of the T assets.

Result: Under the final regulations, the acquisition by P of the assets of T does not satisfy the requirements of a statutory merger or consolidation because T, the combining entity of the transferor unit, does not cease its separate legal existence. Although T is a disregarded entity, it continues to exist as a juridical entity after the conversion.

Notes: The IRS and Treasury are continuing to study whether a stock acquisition followed by a conversion of the acquired entity to a disregarded entity should be permitted to qualify as a statutory merger or consolidation. See Preamble to Treas. Reg. § 1.368-2(b); Treas. Reg. § 1.368-2(b)(1)(iii) ex. 9.

Final Section 368 Regulations

Acquisition and State Law Dissolution

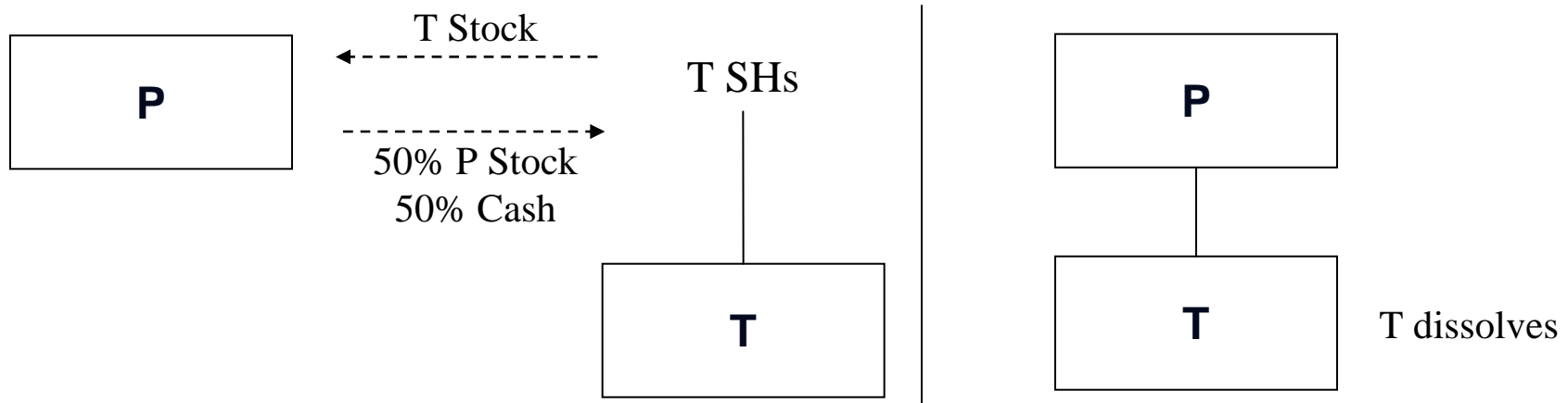

Facts: P acquires the stock of T from the T shareholders in exchange for consideration that consists of 50 percent voting stock of P and 50 percent cash. Immediately after the stock acquisition, T files a certificate of dissolution pursuant to State W law and commences winding up its activities. Under State W dissolution law, ownership and title to T's assets does not automatically vest in P upon dissolution. Instead, T transfers assets to its creditors in satisfaction of its liabilities and transfers its remaining assets to P in the liquidation stage of the dissolution. P's acquisition of the stock of T and the dissolution of T are steps in a single integrated acquisition by P of the assets of T.

Result: The acquisition by P of the assets of T does not qualify as an "A" reorganization because P does not acquire all of the assets of T as a result of T filing the certificate of dissolution or simultaneously with T ceasing its separate legal existence. Instead, P acquires the assets of T by reason of T's transfer of its assets to P. Accordingly, P's acquisition of the assets of T does not qualify as a statutory merger or consolidation. See Treas. Reg. § 1.368-2(b)(1)(iii) ex. 10.

Notes: What if there were no creditors, so all of T's assets are received by P?

What if state dissolution law provided that title to assets automatically vested in P?

What if T sold a portion of its assets to satisfy creditor claims and then dissolved?

See Treas. Reg. § 1.368-2(b)(1)(iii) ex. 8.

Recovery of Basis

Sections 302(d) and 304

Section 304 Transactions

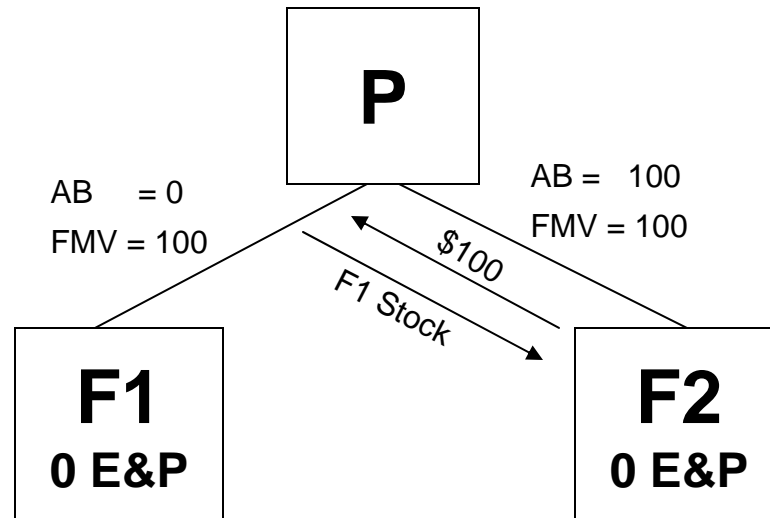

- Under Section 304(a)(1), P is treated as having transferred its F1 stock to F2 in exchange for F2 stock in a Section 351 transaction, and then F2 redeemed the deemed issued stock in a transaction subject to Section 302(d).
- Preamble to TD 9250: P can take into account only the basis of the F2 stock deemed received in exchange for the F1 stock, not the basis in the historic F2 stock.
- The IRS's statements regarding Section 301(c)(2) generally may have stemmed from concerns in the narrow context of Section 304 transactions involving foreign corporations.

Authorities:

T.D. 9250, 2006-11 I.R.B. 588 (March 13, 2006).

Section 302(d) Redemptions

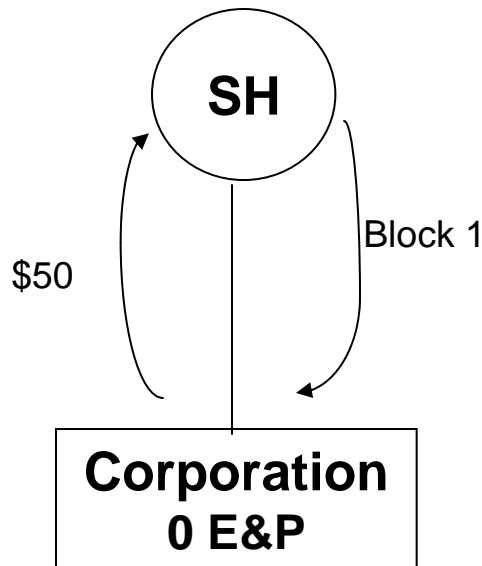

Facts:

	<u>Basis</u>	<u>FMV</u>
Block 1	20	50
Block 2	100	50

- The corporation redeems Block 1 for \$50.
- How much basis is available for Section 301(c)(2) reduction?

Analysis:

<u>Approach</u>	<u>Cash Paid</u>	<u>Available Basis</u>	<u>Section 301(c)(3) Gain</u>	<u>Remaining Basis</u>
Redeemed Shares	50	20 basis in Block 1	30	100 in Block 2
Aggregate Basis	50	120 basis in Block 1 and 2	0	70 in Block 2
All Shares	50	20 basis in Block 1 against half the distribution and 100 basis in Block 2 against half the distribution	5	75 in Block 2
Recap	50	20 basis in Block 1 against half the distribution and 100 basis in Block 2 against half the distribution	5	0 in Block 1 75 in Block 2

Authorities:

New York State Bar Association Tax Section, *Report on Basis Recovery in a Dividend Equivalent Redemption* (June 13, 2006).

What is the Correct Approach?

- In several recent statements, the IRS has indicated that it believes that only the basis of the shares actually redeemed may be recovered (the “Redeemed Shares” approach) and that it is studying the issue. See T.D. 9250; Announcement 2006-30.
- But, the Conference Report relating to the 1984 enactment of Section 1059 stated that the conferees “wish to make clear their intention that if a redemption distribution is treated as a distribution under section 301 rather than a sale or exchange of the redeemed shares under section 302(a), the distribution is treated as made, pro rata, with respect to stock of the shareholder which is not redeemed.” Indeed, Section 1059(e)(1)(A)(iii) applies a Redeemed Shares approach to a specific category of redemptions, implying that the Redeemed Shares approach is not the general rule.

Authorities:

T.D. 9250, 2006-11 I.R.B. 588 (March 13, 2006);
Announcement 2006-30, 2006-19 I.R.B. 879 (May 8, 2006);
H.R. Rep. No. 861, 98th Cong. 2d Sess. (1984);
Treas. Reg. § 1.302-2(c).

Corollary Issues

- Holding period in which block of shares is relevant for purposes of the 61-day holding period requirement under Section 1(h)(11)? Holding period in which block of shares is relevant for purposes of determining whether the shareholder has long-term capital gain under Section 301(c)(3)?
- Does available basis depend on whether the redeemed shares are of the same class as the retained shares?
- If a redemption is treated as a Section 301 distribution because the shareholder constructively owns shares after the redemption, what basis is available to the redeemed shares?
- How much basis is available in a deemed redemption pursuant to Section 304?

Case Law Developments

Black & Decker Transaction

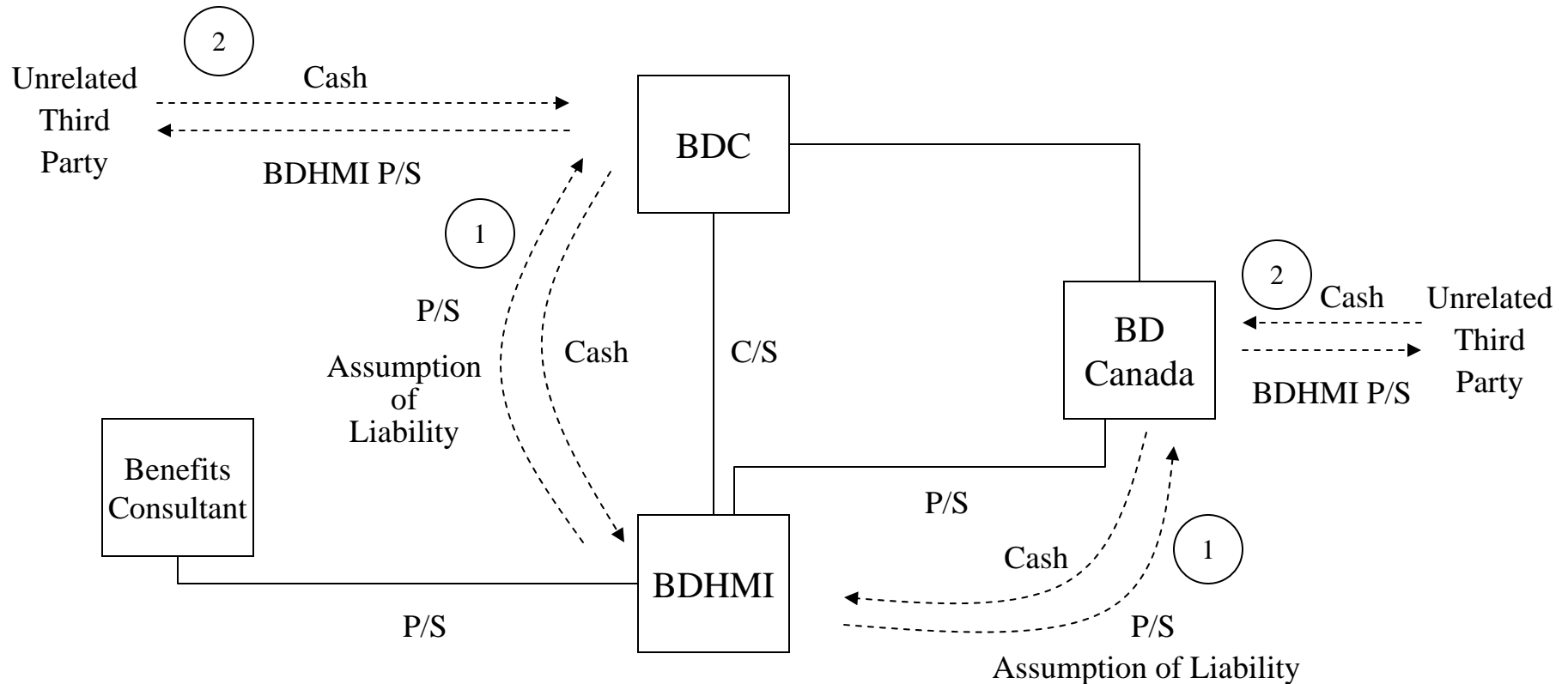

Facts: BDC owned all of the common stock of BDHMI. The preferred stock of BDHMI was owned by a third-party Benefits Consultant and BD Canada, which was a subsidiary of BDC. The following two-step transaction occurred. First, BDC and BD Canada contributed \$561 million in cash to BDHMI in exchange for \$1 million of BDHMI preferred stock and BDHMI's assumption of future health benefits claims against BDC and BD Canada, which the parties valued at \$560 million. Second, BDC and BD Canada sold to the same unrelated third party all of the BDHMI preferred stock received in the exchange 34 days after the exchange for \$1 million. BDC and BD Canada reported a \$560 million capital loss from the sale, the difference between the claimed basis in the preferred stock (\$561 million) and the consideration received in the sale (\$1 million). The Service disallowed the \$560 million capital loss.

Black & Decker

- The Service and the taxpayer filed motions of summary judgment in the District Court of Maryland.
- The District Court denied the Service’s motion for summary judgment, finding that the taxpayer had satisfied the technical requirements under the Code to claim the \$560 million capital loss on the sale of the BDHMI preferred stock. See 2004-2 U.S.T.C. (CCH) ¶ 50,359 (D. Md. 2004).
 - The District Court found that the taxpayer was entitled to claim a high basis in the BDHMI preferred stock because, in the section 351 transfer, the contingent liabilities assumed by BDHMI would give rise to a deduction and, thus, by operation of section 357(c)(3), that assumption of such liabilities would not be treated as a cash transfer by BDHMI to BDC and BD Canada under section 358(d) to reduce the basis in the BDHMI preferred stock received by BDC and BD Canada.
- The District Court granted the taxpayer’s motion summary judgment, rejecting the Service’s argument that the transaction at issue lacked economic substance. See 2004-2 U.S.T.C. (CCH) ¶ 50,390 (D. Md. 2004).
- The District Court relied on the sham transaction doctrine as articulated in *Rice’s Toyota World*, 752 F.2d 89 (4th Cir. 1985), which may disregard a transaction if the court finds that “the taxpayer was motivated by no business purpose other than obtaining tax benefits in entering the transaction, and that the transaction has no economic substance because no probability of profit exists.” The taxpayer had conceded the first prong (i.e., tax avoidance was a motivating factor), but the district court found that the second prong was not satisfied because the transaction had economic substance. In reaching its decision, the district court relied upon the following undisputed facts:
 - BDHMI assumed the responsibility for the management, servicing, and administration of plaintiff’s employee and retiree health plans;
 - BDHMI considered and proposed numerous healthcare cost containment strategies since its inception, many of which have been implemented by Black & Decker;
 - BDHMI has always maintained salaried employees; and
 - BDHMI became responsible for paying the healthcare claims of Black & Decker’s employees and such claims are paid with the corporation’s assets.

Black & Decker

- In *Black & Decker Corp. v. United States*, 436 F.3d 431 (4th Cir. 2006), the 4th Circuit agreed with the lower court's denial of the Service's motion for summary judgment, finding that the transaction satisfied the literal requirements of the Code.
- However, the 4th Circuit remanded the case back to the District Court to determine whether the underlying transaction lacked economic substance.
 - Although the District Court quoted the two-prong test as set out in *Rice's Toyota World*, the Circuit Court found that it misapplied the economic substance prong by focusing on Black and Decker's general business activities rather than "whether a reasonable possibility of profit from the transaction existed apart from tax benefits." (citing *Rice's Toyota World v. Commissioner*, 752 F.2d 89, 94 (4th Cir. 1985))
 - Furthermore, the Circuit Court emphasized the District Court's failure to consider and evaluate the Service's expert witness reports, which would have raised questions about Black and Decker's reasonable expectation of profiting from the transaction. These expert reports, according to the Circuit Court's opinion, created triable issues of fact.
 - Citing to *Hines v. United States*, 912 F.2d 736 (4th Cir. 1990), the 4th Circuit stated that the "ultimate determination of whether an activity is engaged in for profit is to be made...by reference to objective standards." *Id.* at 740.
 - Accordingly, the Circuit Court remanded the economic substance issue to the District Court for trial.

Coltec

- The transaction at issue before the U.S. Court of Federal Claims in *Coltec Industries, Inc. v. United States*, 2004-2 U.S.T.C. (CCH) ¶ 50,402 (Ct. Fed. Cl. 2004) was similar in substance to that at issue in *Black & Decker Corp. v. United States*, 436 F.3d 431 (4th Cir. 2006).
 - Coltec Industries (“Coltec”) transferred contingent asbestos litigation liabilities and an intercompany note to a newly-created subsidiary, formed for the purpose of managing the liabilities, in exchange for common stock in the subsidiary.
 - Coltec then sold the common stock received in the exchange to unrelated third parties. Coltec claimed \$370 million in capital losses from the stock sales.
 - Two years later, Coltec sold additional common stock in the subsidiary to a select group of lawyers involved in defending its asbestos claims to provide these lawyers an additional performance incentive.
- The Court of Federal Claims entered judgment in favor of Coltec, upholding the \$370 million capital loss claimed by Coltec from the contingent liability transaction at issue in this tax refund litigation.
- The Court of Federal Claims relied on the District Court analysis in *Black & Decker* to hold that the operation of the applicable code sections justified a capital loss.
- Moreover, the Court of Federal Claims rejected the government’s argument that the capital loss should nonetheless be disallowed under the economic substance doctrine.
 - The court refused to apply the economic substance doctrine to the transaction because the transaction satisfied the statutory requirements of the Code. The court stated: “[I]t is Congress, not the court, that should determine how the federal tax laws should be used to promote economic welfare.... Where the taxpayer has satisfied all statutory requirements established by Congress, as Coltec did in this case, the use of the ‘economic substance’ doctrine to trump ‘mere compliance with the Code’ would violate the separation of powers.”

Coltec

- On appeal, the Federal Circuit Court of Appeals concluded that although Coltec's claimed capital loss fell within the literal terms of the statute, the transaction that created the high basis in the stock lacked economic substance and, therefore, must be disregarded for tax purposes. *Coltec v. United States*, 2006-2 U.S.T.C. (CCH) ¶ 50,389 (Fed. Cir. 2006).
- The Federal Circuit upheld the Court of Federal Claims' conclusion that Coltec's basis in the stock of its subsidiary should not be reduced by the amount of the contingent asbestos liabilities transferred to the subsidiary under a literal application of the relevant Code provisions.
- On the issue of economic substance, however, the Federal Circuit flatly rejected the Court of Federal Claims' holding that the use of the economic substance doctrine to trump compliance with the Code violates the separation of powers, faulting the court for failing to follow binding precedent of the Supreme Court and the Federal Circuit's predecessor court, the Court of Claims.
- The court further rejected the economic substance test adopted by the 4th Circuit in *Black and Decker*—that a transaction will be disregarded only if it *both* lacks economic substance and is motivated solely by tax avoidance—instead adopting a disjunctive approach to disregard a transaction that *either* lacks economic substance or is motivated solely by tax avoidance.
- In applying the economic substance test, the Federal Circuit focused solely on the transaction giving Coltec the high stock basis (i.e., the assumption of the liabilities in exchange for the note) and concluded that Coltec had not demonstrated any business purpose for that transaction. The court rejected Coltec's claim that it would strengthen its position against potential veil-piercing claims, since it only affected relations among Coltec and its own subsidiaries and had no effect on third parties.
- The Federal Circuit's decision in *Coltec* raises many questions about the scope of the economic substance doctrine and how that doctrine might apply to many other transactions that technically comply with explicit Code provisions.