

PRACTISING LAW INSTITUTE
TAX STRATEGIES FOR CORPORATE ACQUISITIONS,
DISPOSITIONS, SPIN-OFFS, JOINT VENTURES,
FINANCINGS, REORGANIZATIONS AND
RESTRUCTURINGS 2010

June 2011

Recent Developments in the Step Transaction Doctrine

By

Mark J. Silverman
Steptoe & Johnson LLP
Washington, D.C.

Copyright © 2011, by Mark J. Silverman. All Rights Reserved.

TABLE OF CONTENTS

Internal Revenue Service Circular 230 Disclosure: As provided for in Treasury regulations, advice (if any) relating to federal taxes that is contained in this communication (including attachments) is not intended or written to be used, and cannot be used, for the purpose of (1) avoiding penalties under the Internal Revenue Code or (2) promoting, marketing or recommending to another party any plan or arrangement addressed herein.

	<u>Page</u>
A. Introduction	3
1. <u>Binding Commitment Test</u>	3
2. <u>Interdependence Test</u>	4
3. <u>End Results Test</u>	4
B. Examples	5
1. <u>Example 1 -- “Firm and Fixed Plan”: <i>Merrill Lynch</i></u>	5
2. <u>Example 2 – <i>Heinz</i></u>	9
3. <u>Example 3 -- <i>Times Mirror</i></u>	13
4. <u>Example 4 -- PLR 200427011</u>	17
5. <u>Example 5 -- Creeping “B” Reorganization</u>	20
6. <u>Example 6 -- Rev. Rul. 67-274</u>	22
7. <u>Example 7 -- Rev. Rul. 2001-24</u>	23
8. <u>Example 8 -- Rev. Rul. 2002-85</u>	25
9. <u>Example 9 -- Rev. Rul. 2001-25</u>	28
10. <u>Example 10 -- Rev. Rul. 69-617</u>	30
11. <u>Example 11 -- <i>Bausch & Lomb</i> and Treas. Reg. § 1.368-2(d)(4)</u>	32
12. <u>Example 12 -- Asset Push-up After Triangular “C” Reorganization</u>	36
13. <u>Example 13 -- <i>Elkhorn Coal</i></u>	39
14. <u>Example 14 -- Rev. Rul. 2003-79</u>	40
15. <u>Example 15 -- Rev. Rul. 96-29</u>	42
16. <u>Example 16 -- <i>King Enterprises</i></u>	44
17. <u>Example 17 -- <i>Yoc Heating</i></u>	47
18. <u>Example 18 -- Rev. Rul. 90-95</u>	49
19. <u>Example 19 -- Rev. Rul. 2001-26</u>	50
20. <u>Example 20 -- Rev. Rul. 2001-46: Situation 1</u>	52
21. <u>Example 21 -- Rev. Rul. 2001-46: Situation 2</u>	54
22. <u>Example 22 -- Rev. Rul. 2008-25</u>	58
23. <u>Example 23 -- Rev. Rul. 2004-83</u>	60
24. <u>Example 24 -- Section 304 or “D” Reorganization</u>	61
25. <u>Example 25 -- Rev. Rul. 70-140</u>	63
26. <u>Example 26 -- Rev. Rul. 2003-51</u>	64
27. <u>Example 27 -- Assumption of Liabilities in Triangular “C” Reorganizations</u>	66
28. <u>Example 28 -- “Cause To Be Directed” Transfer</u>	70
29. <u>Example 29 -- Sale of All of QSub Stock: Rev. Rul. 70-140</u>	73
30. <u>Example 30 -- Sale of Portion of QSub Stock</u>	74
31. <u>Example 31 -- Sale of All Membership Interests in LLC</u>	75
32. <u>Example 32 -- Sale of Portion of Membership Interests in LLC</u>	76
33. <u>Example 33 -- Revenue Ruling 98-27</u>	80
34. <u>Example 34 – <i>Schering Plough</i></u>	84
35. <u>Example 35 – <i>Fidelity International</i></u>	89

Recent Development in the Step Transaction Doctrine: Issues and Examples¹

A. Introduction

In general, whether two transactions should be “stepped together” will depend upon the facts and circumstances of the transaction. Courts have developed a number of approaches for dealing with step transaction issues. Most prevalent are the binding commitment test, the interdependence test, and the end result test. *See McDonald's Restaurants of Illinois, Inc. v. Commissioner*, 688 F.2d 520 (7th Cir. 1982). *See also* FSA 199929013 (Apr. 19, 1999) (applying all three tests in determining whether the continuity of interest requirement under section 355 was satisfied). *Cf. True v. United States*, 190 F.3d 1165 (10th Cir. 1999) (noting that a transaction needs to satisfy only one of the tests to apply the step transaction doctrine). *See also Andantech, L.L.C. v. Commissioner*, T.C. Memo. 2002-97 (2002) (citing *True* and holding that partnership in sale-leaseback transaction should be disregarded under both the interdependence and end result tests).

1. Binding Commitment Test

Under the binding commitment test, a series of transactions will be stepped together only if at the time that the first step is commenced there is a binding legal commitment to undertake the subsequent step(s). *See, e.g., Commissioner v. Gordon*, 391 U.S. 83 (1968); *see also* FSA 200117020 (Jan. 24, 2001) (applying the binding commitment test to a subsidiary’s transfer of parent stock to the parent’s employees), FSA 200126001 (Oct. 8, 1999) (applying the binding commitment test to disregard the existence of a transitory corporation in a leveraged buyout transaction). This test is the narrowest of the three tests, and may be easily avoided without substantial business risks in transactions where the parties share the same goal of tax-free treatment, or are under common control.

¹ Mr. Silverman would like to acknowledge the contributions of Alexis MacIvor of Steptoe & Johnson LLP.

2. Interdependence Test

Under the interdependence test, a series of transactions will be stepped together if the steps are so interdependent that the legal relations created by one transaction would have been fruitless without a completion of the series. *See, e.g., King Enterprises, Inc. v. United States*, 418 F.2d 511 (Ct. Cl. 1969); Rev. Rul. 2001-26, 2001-1 CB 1297; FSA 200221046 (Feb. 19, 2002) (applying interdependence test to integrate a multi-step transfer of a domestic corporation's transfer of its foreign subsidiaries to its foreign parent corporation thereby subjecting the transfer to section 367(a)); *Falconwood Corporation v. United States*, 422 F.3d 1339 (Fed. Cir. 2005). This test is similar to the end result test discussed below, in that it focuses on the subjective intent of the parties. However, if any independent purpose is served by an intermediate step it may be sufficient to prevent the application of the step transaction doctrine under the interdependence test where it would not be under the end result test.

3. End Results Test

Under the end result test, a series of transactions will be stepped together whenever the evidence shows that the parties' intent at the outset was to achieve the particular result, and that the separate steps were all entered into as means of achieving that result. *See, e.g., Kuper v. Commissioner*, 533 F.2d 152 (5th Cir. 1976). This test would result in application of the step transaction doctrine under almost any transaction where the same result could have been achieved in a more direct manner. *See also Del Commercial Properties, Inc. v. Commissioner*, 251 F.3d 210 (D.C. Cir. 2001) (“[A] particular step is disregarded for tax purposes if the taxpayer could have achieved its objective more directly, but instead included the step for no other purpose than to avoid U.S. taxes.”); FSA 200122007 (Feb. 13, 2001) (noting that courts are seldom rigid in applying the end result test and that courts will look at the intent of the parties and the time interval between steps).

B. Examples

1. Example 1 -- “Firm and Fixed Plan”: *Merrill Lynch*

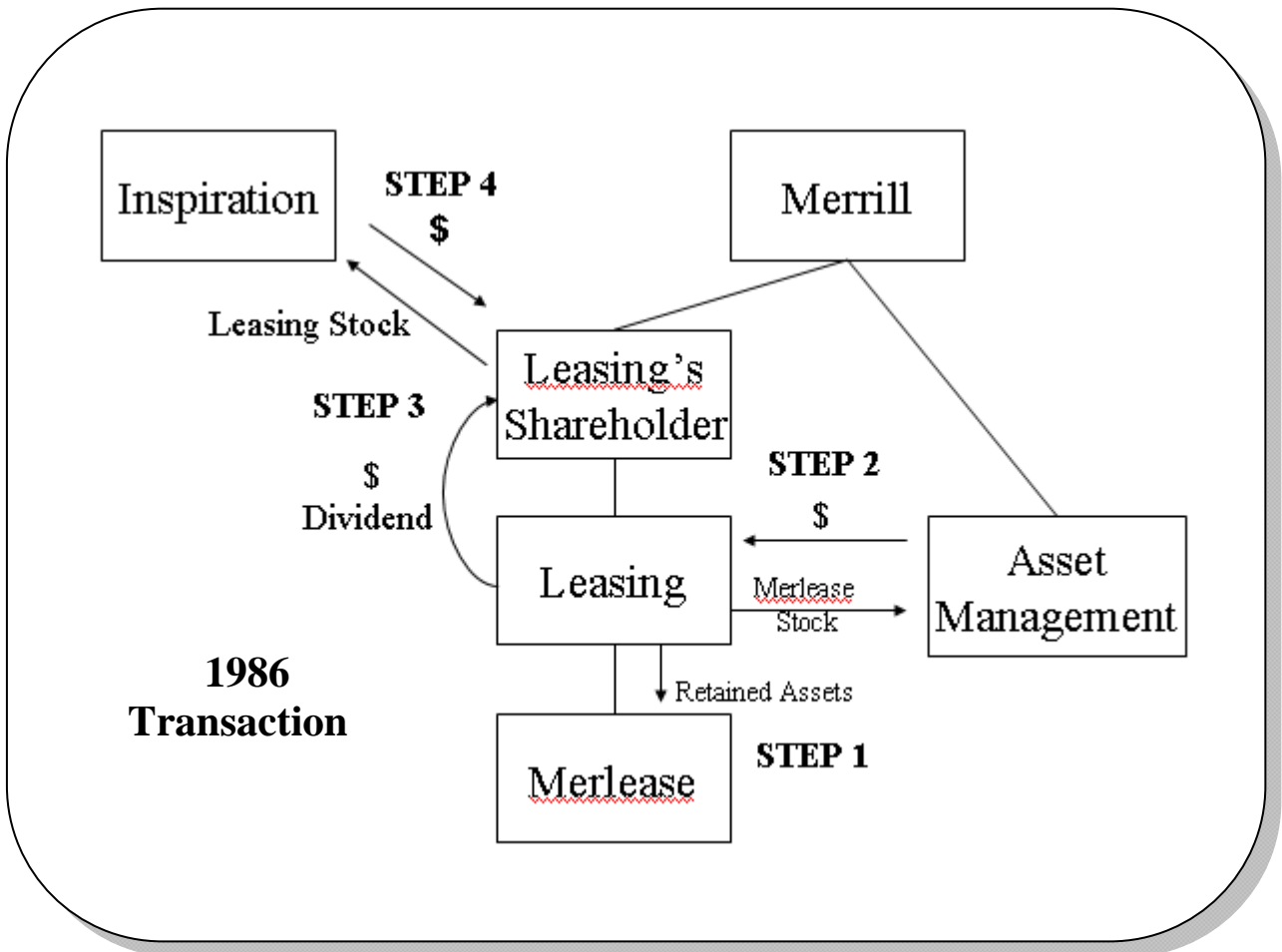

- a. Facts: In *Merrill Lynch & Co., Inc. & Subsidiaries v. Commissioner*, 120 T.C. 12 (2003), Merrill Lynch & Company, Inc. (“Merrill”) was the parent of a consolidated group. Merlease Leasing Corp. (“Merlease”), Merrill Lynch Leasing, Inc. (“Leasing”), Merrill Lynch Capital Resources (“Leasing’s Shareholder”), and Merrill Lynch Asset Management, Inc. (“Asset Management”) were subsidiaries of Merrill and members of Merrill’s consolidated group. Leasing owned all of the stock of Merlease.

In 1986, Leasing sold its Merlease stock to Asset Management in a cross-chain stock sale (the “1986 Transaction”) involving the following steps:

- (1) Leasing contributed certain retained assets to Merlease that Merrill did not want to sell to Inspiration.

- (2) Leasing sold Merlease cross-chain to a sister subsidiary, Asset Management, in a section 304 transaction.
- (3) Leasing distributed the gross sale proceeds to Leasing's Shareholder as a dividend.

Following the completion of step (3), Leasing's Shareholder sold Leasing to Inspiration, an unrelated third party.

Merrill took the position that Leasing's cross-chain stock sale was properly characterized as a dividend under the rules of section 304(a)(1). Section 304(a) required a cross-chain stock sale to be treated as a redemption of stock subject to the rules of sections 302 and 301. As a result, Merrill took the position that the cross-chain stock sale should be evaluated under section 302 immediately after the completion of the sale. Immediately after the completion of the cross-chain stock sale, Leasing constructively owned, under section 318, a number of Merlease shares that prevented the cross-chain stock sale from qualifying as a sale or exchange under section 302(b). Therefore, Merrill concluded that the cross-chain stock sale resulted in a dividend to Leasing.

Under the consolidated return regulations in effect at the time, the dividend arising from the cross-chain stock sale increased the earnings and profits of Leasing. As a result of this increase in Leasing's earnings and profits, Leasing's shareholder (also a member of the Merrill consolidated group) increased its basis in its Leasing shares prior to an anticipated sale of Leasing to an unrelated third party. Treas. Reg. § 1.1502-33; Treas. Reg. § 1.1502-32. Thus, when the Merrill consolidated group sold Leasing to Inspiration, an unrelated third party, the seller was able to recognize a loss on the sale.

In 1987, Merrill completed a similar transaction and took the same position with respect to that transaction ("the 1987 transaction").

- b. Issue: Should the cross-chain sales be treated as dividends or sales or exchanges?
 - (1) The Service denied the loss arising from the sale of Leasing in the 1986 transaction. The Service agreed that the cross-chain stock sale should be treated as a redemption under section 304(a). However, the Service contended that the redemption created by the cross-chain stock sale must be combined with the subsequent sale of Leasing to a non-member when determining if the redemption was a sale or exchange or a dividend under section 302. According to the Service, the cross-chain stock sale and the subsequent

sale of Leasing to a non-member were steps of a fixed, firm plan undertaken to dispose of Leasing to a non-member. Thus, the cross-chain stock sale could only be evaluated under section 302 in conjunction with the sale of Leasing to the non-member. When the cross-chain stock sale's status under section 302(b) was evaluated in this manner, the deemed redemption arising from the cross-chain stock sale was a sale or exchange under section 302(b)(3) because the cross-chain stock sale and subsequent sale of Leasing resulted in the complete termination of Leasing's actual and constructive ownership interest in Merlease.

- (2) The Tax Court agreed with the Service. Judge Marvel noted that a "firm and fixed plan does not exist for purposes of section 302 when there is only a 'vague anticipation' that a particular step in an alleged plan will occur." However, Judge Marvel believed that, in Merrill's case, "the facts establish the existence of much more than a vague anticipation that the sale of Leasing would occur." Judge Marvel noted:

The principal, and most compelling, evidence on which we rely is the formal presentation of the plan to Merrill Parent's board of directors, which took place on July 28, 1986, only 4 days *after* the cross-chain sale of [stock]. The formal presentation included the distribution of a written summary and slides illustrating the details of the plan to dispose of petitioner's proprietary lease business culminating in the sale of [Leasing]. The written summary laid out each step of the plan. Among the steps identified were (1) the cross-chain sale of [stock], which the summary acknowledged had already occurred ... and (3) the imminent sale of [Leasing] to [an unrelated third party]. The written summary described the tax benefits of the plan, which were predicated on an increase in ... basis in [Leasing] under the consolidated return regulations for the proceeds of the cross-chain sale. The written summary confirmed that the plan included the sale of [Leasing] and unequivocally identified [unrelated third party] as the purchaser.

In light of these facts, according to the court, "a firm and fixed plan to dispose of Leasing existed on the date of the cross-chain sale." Therefore, for purposes of determining if the cross-chain sale should be treated as a dividend or a sale or exchange, the Tax Court held that the cross-chain stock sale and the subsequent sale of Leasing to a non-member must be considered a single transaction. As a

single transaction, the cross-chain stock sale and sale of Leasing constituted a complete termination of Leasing's interest in Merlease, and, therefore, a sale or exchange under section 302 that did not increase the selling group member's basis in its Leasing shares.

- (3) The Tax Court ruled that the cross-chain sale, dividend, and sale of MLL to Inspiration were steps in a plan to terminate MLL's ownership of Merlease and the section 304 redemption was therefore subject to sale or exchange treatment because it represented a complete termination of MLL's interest in Merlease under section 302(b)(3). The Court concluded that the cross-chain sale and sale of MLL to Inspiration represented a "firm and fixed" plan to terminate MLL's interest in Merlease for purposes of determining whether the section 304 redemption should be treated as a sale or exchange or a dividend. *Merrill Lynch v. Commissioner*, 120 T.C. 12 (2003). The Tax Court reached a similar conclusion with respect to the 1987 transaction.
- (4) On appeal, the Second Circuit did not address the 1986 transaction. The court held that in the 1987 transaction, Merrill had a firm and fixed plan to sell the subsidiary at the time the cross-chain sales were executed. The court remanded the case to consider whether the section 318 attribution rules should apply to the integrated transactions to determine if the cross-chain sales were, in fact, constructive distributions. Merrill had not made this argument at the Tax Court level. *See Merrill Lynch v. Commissioner*, 386 F.3d 464 (2nd Cir. 2004).

2. Example 2 – Heinz

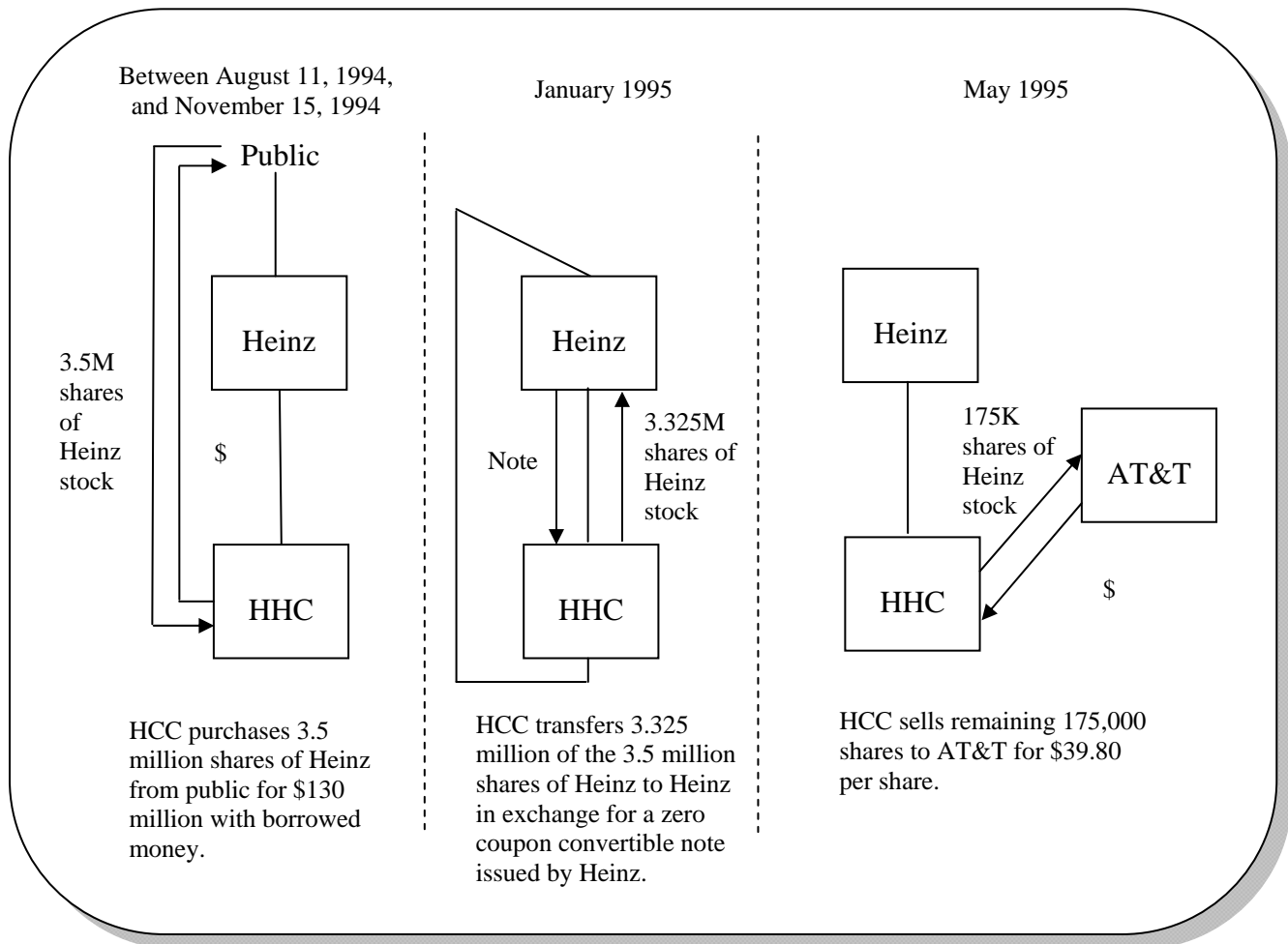

- a. Facts: In *H. J. Heinz Company and Subsidiaries v. United States*, 76 Fed. Cl. 570 (2007), the Court of Federal Claims rejected taxpayers’ claim for refund arising out of an alleged redemption transaction.
- (1) Between August 11, 1994, and November 15, 1994, H.J. Heinz Credit Company (“HCC”), a subsidiary of the H.J. Heinz Company (“Heinz”), purchased 3.5 million shares of Heinz common stock in the public market for \$130 million. HCC financed these purchases by borrowing from the Morgan Guaranty Trust Company of New York.
 - (2) In January of 1995, HCC transferred 3.325 million of the 3.5 million shares to Heinz in exchange for a zero coupon convertible note (“Note”) issued by Heinz.
 - (3) In May of 1995, HCC sold the remaining 175,000 shares to AT&T Investment Management Corp. (“AT&T”), an

unrelated party, for a discounted rate of \$39.80 per share, or \$6,966,120, in cash. As a result of this sale, HCC realized a capital loss, which the Heinz consolidated group claimed and carried back to 1994, 1993, and 1992.

- b. Issue: Whether Heinz may deduct HCC's capital loss of \$124 million from its May 1995 sale of the 175,000 shares of Heinz stock to AT&T.
- (1) Heinz asserted that, under section 317(b), the January 1995 sale of stock to Heinz was a redemption that should be taxed as a section 302(d) dividend. Accordingly, HCC's basis in the redeemed stock should be added to its basis in the 175,000 shares that it retained, and HCC recognized a capital loss when it sold the 175,000 shares to AT&T.
 - (2) The Service disallowed Heinz's claimed capital loss arguing that (i) the January 1995 sale of stock to Heinz did not qualify as a redemption under section 317(b), (ii) the transaction lacked economic substance and had no bona fide business purpose other than to produce tax benefits (sham transaction doctrine), and (iii) the transaction should be viewed as a direct purchase of the 3.325 million shares by Heinz under the step transaction doctrine.
 - (3) Section 317(b): The court held that, setting aside other substance-over form considerations, it appears preliminarily that HCC possessed the burdens and benefits associated with the Heinz stock and that the redemption qualified under section 317(b).
 - (4) Sham: The court held that the transaction was a sham. The court stated that it "will not don blinders to the realities of the transaction before it. Stripped of its veneer, the acquisition by HCC of the Heinz stock had one purpose, and one purpose alone — producing capital losses that could be carried back to wipe out prior capital gains. There was no other genuine business purpose. As such, under the prevailing standard, the transaction in question must be viewed as a sham — a transaction imbued with no significant tax-independent considerations, but rather characterized, at least in terms of HCC's participation, solely by tax-avoidance features."
 - (5) Step Transaction Doctrine: The court also held that capital loss should be denied under both the end result test and the interdependence test of the step transaction doctrine.

- a) In applying the end result formulation of the step transaction doctrine, the court concluded that Heinz intended from the outset to redeem its stock which HCC held.
- i) The court pointed to correspondence between the taxpayer and Goldman Sachs & Co., showing that HCC hired Goldman Sachs to design the Note, which Heinz used to effectuate the redemption, before HCC was authorized to buy its first share of Heinz stock.
 - ii) Moreover, Mr. John C. Crowe, Vice President for Tax of Heinz, admitted that “the primary purpose [of the transaction] was to put the company in the position of being able to realize a tax benefit from the possible future sale of the shares.”
 - iii) Thus, the court concluded that HCC’s acquisition of Heinz stock and the subsequent redemption of that stock were “really component parts of a single transaction intended from the outset to be taken for the purpose of reaching the ultimate result.” *Falconwood*, 422 F.3d at 1350 (quoting *King Enterprises*, 418 F.2d at 516).
- b) Analyzing the transaction under the interdependence test, the court noted the similarity between the interdependence test and the business purpose doctrine and concluded that the purchase by HCC of Heinz stock lacked any non-tax business purpose. The court concluded that HCC’s purchase was made neither for investment purposes nor for state tax considerations, as alleged by the taxpayers. The court also held that the main purpose of the stock repurchase program – which was to fulfill Heinz’s need for treasury stock – could not be accomplished as long as the Heinz stock resided in the HCC treasury.
- c) Therefore, applying either the end result or interdependence tests, the court concluded that HCC’s ownership of the Heinz stock was to be

ignored, with Heinz being viewed as having acquired that stock from the public market.

3. Example 3 -- Times Mirror

a. Basic Capitalization Transactions

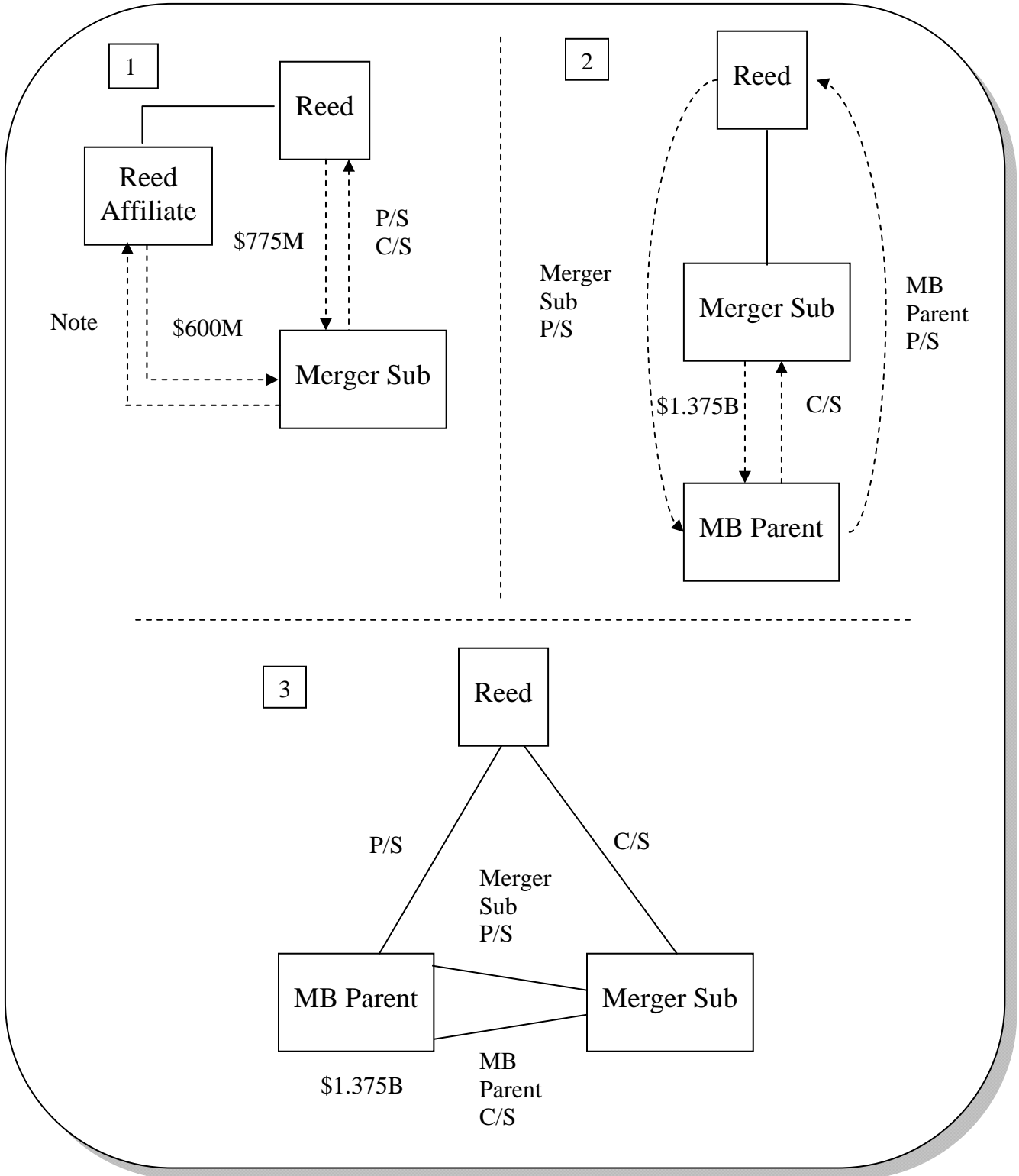

b. Merger and LLC Formation

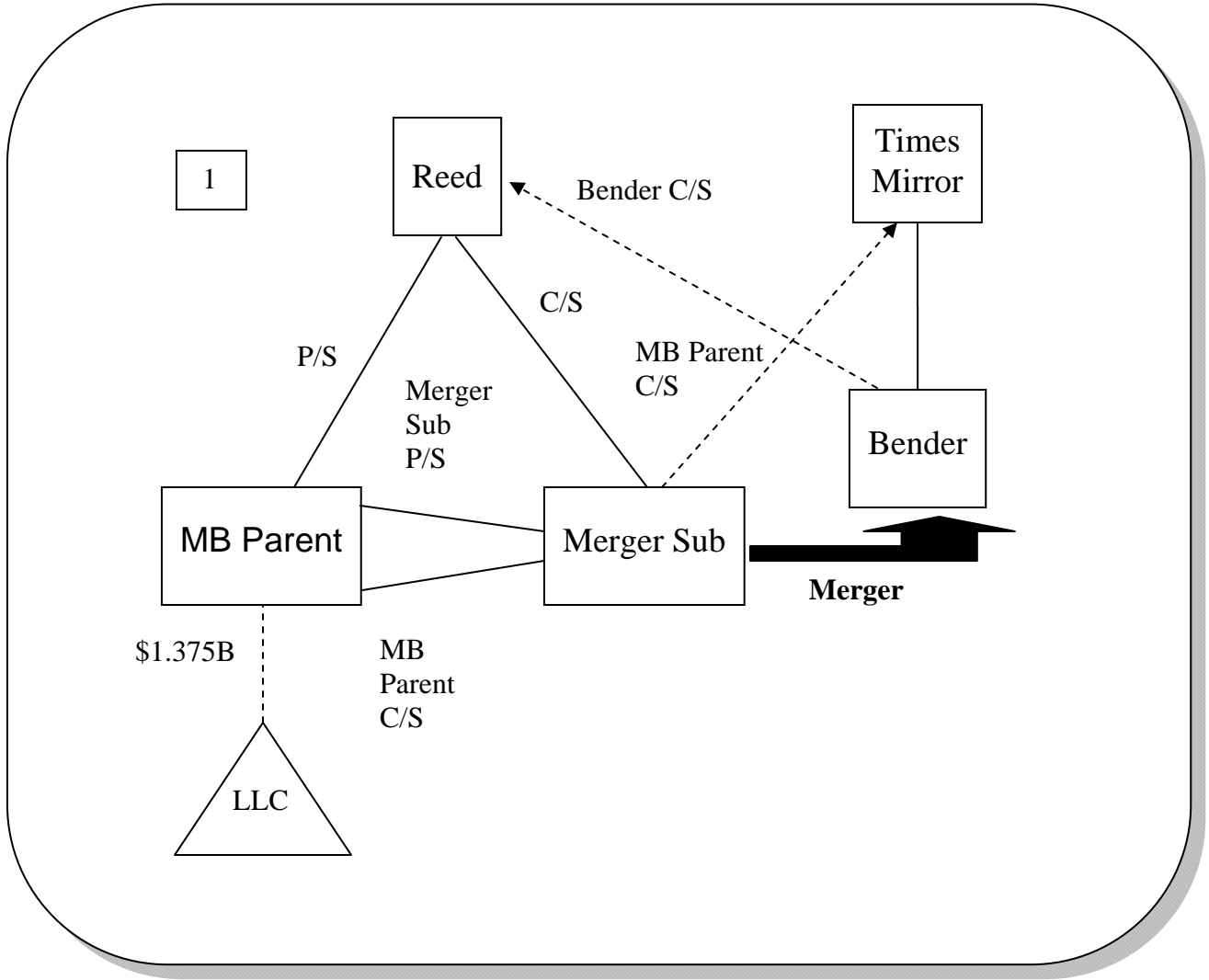

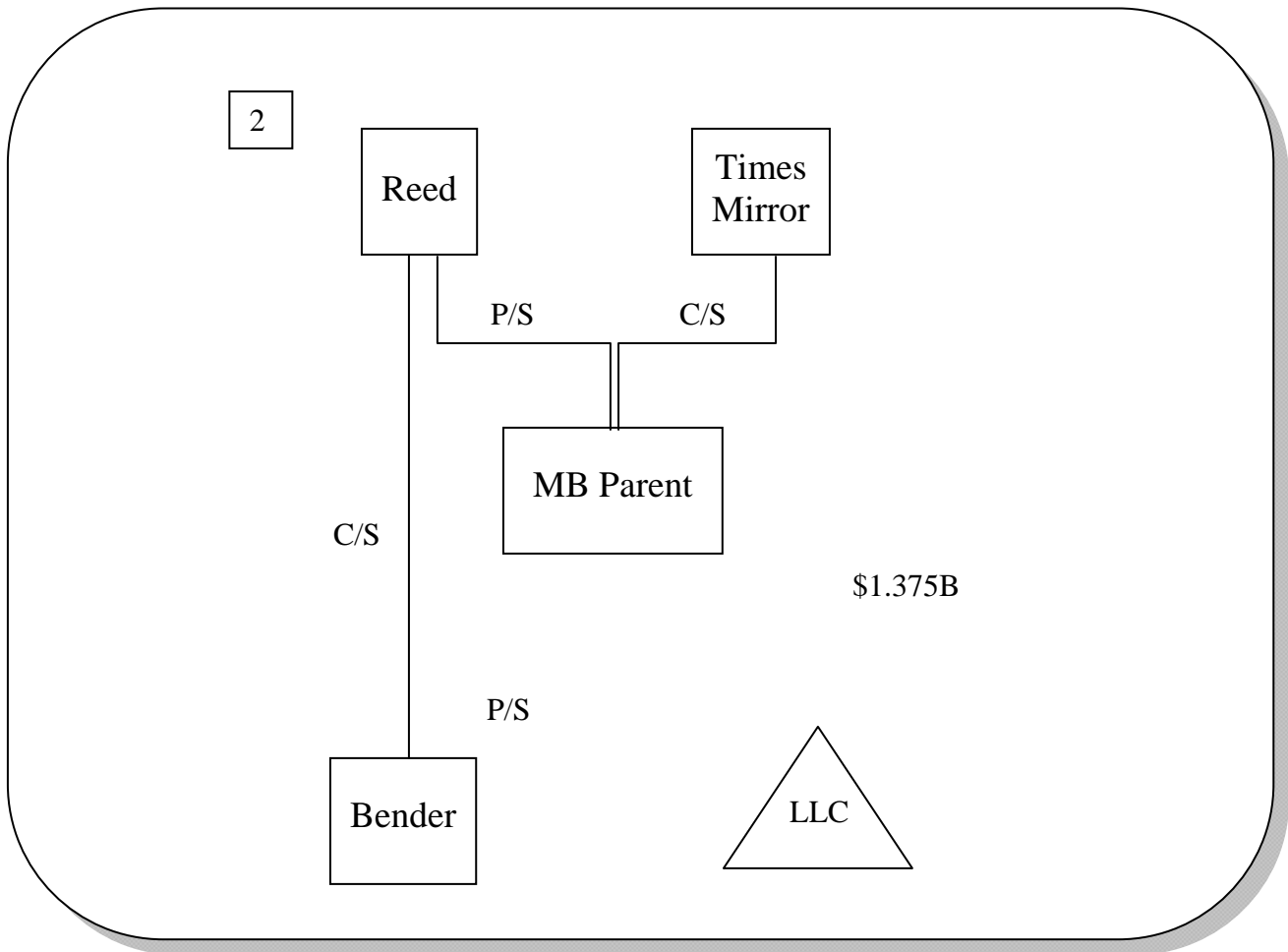

- c. Facts: In *Tribune Company v. Commissioner*, 125 T.C. 110 (2005), the Times Mirror Co., Inc., (“Times Mirror”) was engaged in the legal publishing business but, due to consolidation within the industry, decided that it should divest itself of its wholly owned subsidiary Matthew Bender & Co., Inc (“Bender”). Reed Elsevier (“Reed”), the purchaser, contributed \$775M to Merger Sub in exchange for the preferred stock (“P/S”) and common stock (“C/S”) of Merger Sub. The P/S and C/S of Merger Sub constituted 80 percent and 20 percent of the voting power in Merger Sub, respectively. Merger Sub borrowed \$600M from Luxembourg affiliate of Reed. Reed then contributed its P/S of Merger Sub to MB Parent, a special purpose corporation, in exchange for the P/S of MB Parent, which also constituted 80 percent of the voting power in MB Parent. Merger Sub contributed \$1.375B to MB Parent in exchange for the C/S of MB Parent, which constitutes 20 percent of the voting power in MB Parent.

Prior to the merger, MB Parent formed a limited liability company (“LLC”). The parties used this LLC as a vehicle for the sale of Bender legal publishing subsidiary. Merger Sub merged into Bender and Times Mirror exchanged its Bender stock for the C/S

of MB Parent in a transaction designed to be tax-free under section 368(a)(1)(A) by reason of section 368(a)(2)(E) (i.e., a reverse subsidiary merger).

Times Mirror transferred its Bender stock to MB Parent in exchange for MB Parent's common stock; that stock possessed 20 percent of the voting power of all MB Parent's outstanding stock. Reed received the remaining voting rights via its preferred stock holdings. Immediately after the merger, Times Mirror became the manager of LLC pursuant to the LLC agreement and, upon Times Mirror becoming manager, MB Parent contributed the \$1.375 billion (initially from Reed) to the LLC pursuant to the merger agreement.

- d. Issue: Whether the transaction qualified as a tax-free reorganization under either §368(a)(1)(A) and (2)(E) or section 368(a)(1)(B)?

The Tax Court held that Times Mirror's divestiture of Bender did not qualify as a tax-free reverse triangular merger because it did not meet the "control for voting stock" requirement of section 368(a)(2)(E). That provision requires that the former shareholders of the acquired corporation must exchange a controlling amount of stock (within the meaning of section 368(c)) in the acquired corporation for voting stock of the controlling corporation. *See* Reg. § 1.368-2(j)(3)(i). Section 368(c) defines "control" as "the ownership of stock possessing at least 80 percent of the total combined voting power of all classes of stock entitled to vote and at least 80 percent of the total number of shares of all other classes of stock of the corporation."

Because Times Mirror received more than just "qualified stock" as consideration for its stock in Bender, the Tax Court concluded there was no reorganization under §368(a)(2)(E). The consideration included both the voting common stock issued by MB Parent and the right to control the LLC's cash, which had been deposited by MB Parent. The court noted that the "management authority" secured by TMC with respect to the LLC's cash had "far more value" than the MB Parent stock received. Therefore it was clear that MB Parent had conveyed much less than 80 percent of the aggregate consideration by transferring its stock.

Relying upon progeny of *Gregory v. Helvering*, 293 U.S. 465 (1935), the Tax Court held that "(1) the MB Parent common stock cannot be isolated and treated as the sole consideration transferred to [Times Mirror] for its divestiture of Bender and (2) the common stock of MB Parent, objectively, had a value less than \$1.1 billion and less than 80 percent of the \$1.375 billion paid by Reed."

4. Example 4 -- PLR 200427011

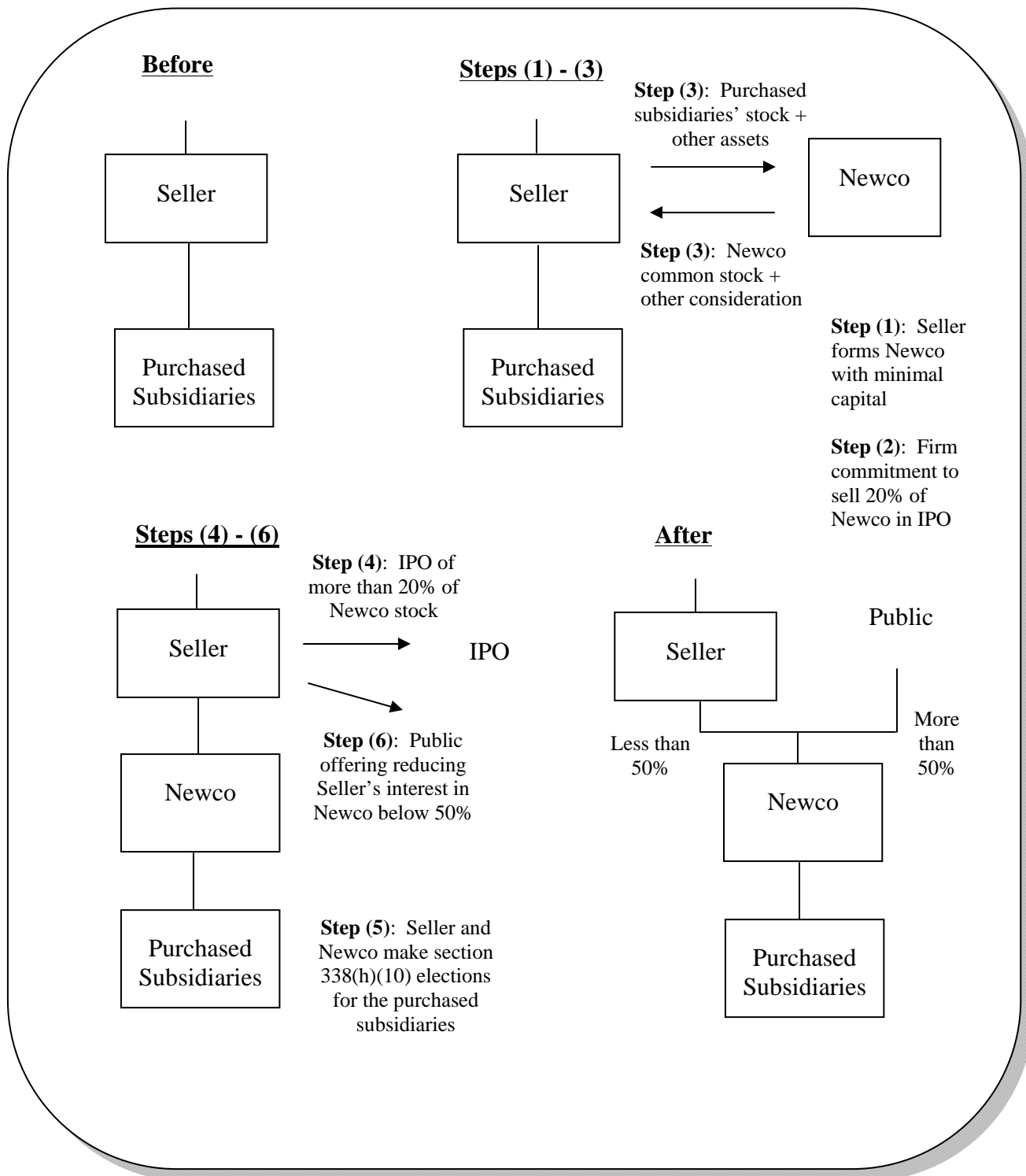

- a. Facts: Parent was a publicly traded corporation that is the common parent of a group of corporations filing a consolidated return. Seller, an indirect subsidiary, was a holding company for a group of corporations (the “purchased subs”) which operated in the financial services and insurance industry. Parent wanted to reduce its investment in the financial services and insurance business. Accordingly, it adopted a plan of divestiture involving the following steps:
- (1) Seller will form Newco with a minimal amount of capital;
 - (2) Seller will enter into a firm commitment to sell more than 20 percent of the Newco common stock and substantially all of the convertible debt instruments of Newco in an IPO;
 - (3) Seller will transfer the purchased subs in exchange for 100 percent of Newco’s common stock, 100 percent of the convertible debt instruments, Newco’s assumption of certain Seller liabilities, and additional non-stock consideration;
 - (4) Seller will sell more than 20 percent of Newco common stock and substantially all of the convertible debt instruments in an IPO pursuant to the firm commitment described in (2), above;
 - (5) Newco and Parent will make timely elections under section 338(h)(10) in respect of certain purchased subs; and
 - (6) Within a certain number of months, Seller will undertake one or more additional public offerings, reducing its interest in Newco to less than 50 percent.
- b. Issues: Are Parent and Newco entitled to make section 338(h)(10) elections with respect to the purchased subs?
- (1) An election under section 338(h)(10) may be made only if the acquisition of the purchased subs by Newco constitutes a qualified stock purchase (a “QSP”).
 - a) A QSP is defined as any transaction or series of transactions in which stock (meeting the requirements of section 1504(a)(2)) of a corporation is acquired by another corporation by “purchase” during the “12-month acquisition period.” Section 338(d)(3).
 - b) In general, a “purchase” is defined as any acquisition of stock, but only if:

- i) The basis of the stock in the hands of the purchasing corporation is not determined in whole or in part by reference to the adjusted basis of the selling corporation in such stock;
 - ii) The stock is not acquired in an exchange to which section 351, 354, 355, or 355 applies;
 - iii) The stock is not acquired from a person the ownership of whose stock, under section 318(a), would be attributed to the person acquiring such stock. *See* section 338(h)(3).

- (2) It would appear that the acquisition of the purchased sub stock by Newco does not satisfy requirements (i) and (iii). If steps (2) through (6) of the transaction are not integrated, it would appear that the transaction is subject to the rules of section 304, because Seller would be in “control” of Newco immediately after the transfer of the purchased sub stock. Thus, the transfer of the stock of the purchased subs to Newco would be treated as a contribution to Newco’s capital, and Newco’s basis in the stock of the purchased subs would be determined by reference to Seller’s basis in such shares. Moreover, immediately after the transfer, Seller would own more than 50% of Newco’s shares. Therefore, Newco would be treated as acquiring the stock of the purchased subs from a person (Seller), the ownership of whose stock, under section 318(a)(3)(C), would be attributed to Newco.

- (3) The Service, however, ruled that Newco’s acquisition of the purchased subs from Seller were QSPs within the meaning of section 338(d)(3), thus making Parent and Newco eligible to make section 338(h)(10) elections for the purchased subs.
 - a) In reaching this conclusion, the Service integrated steps (2) through (6).
 - b) As a result, upon the completion of the integrated transaction, Seller is treated as owning less than 50 percent of Newco’s outstanding stock. Accordingly, the transfer of the Purchased Subsidiaries’ stock to Newco is not subject to section 304 (because Seller is not in “control” of Newco following the completion of the integrated transaction) and the attribution rules of section 318.

- c) Therefore, each acquisition of stock of a purchased sub by Newco constitutes a purchase under section 338(h)(3).

5. Example 5 -- Creeping “B” Reorganization

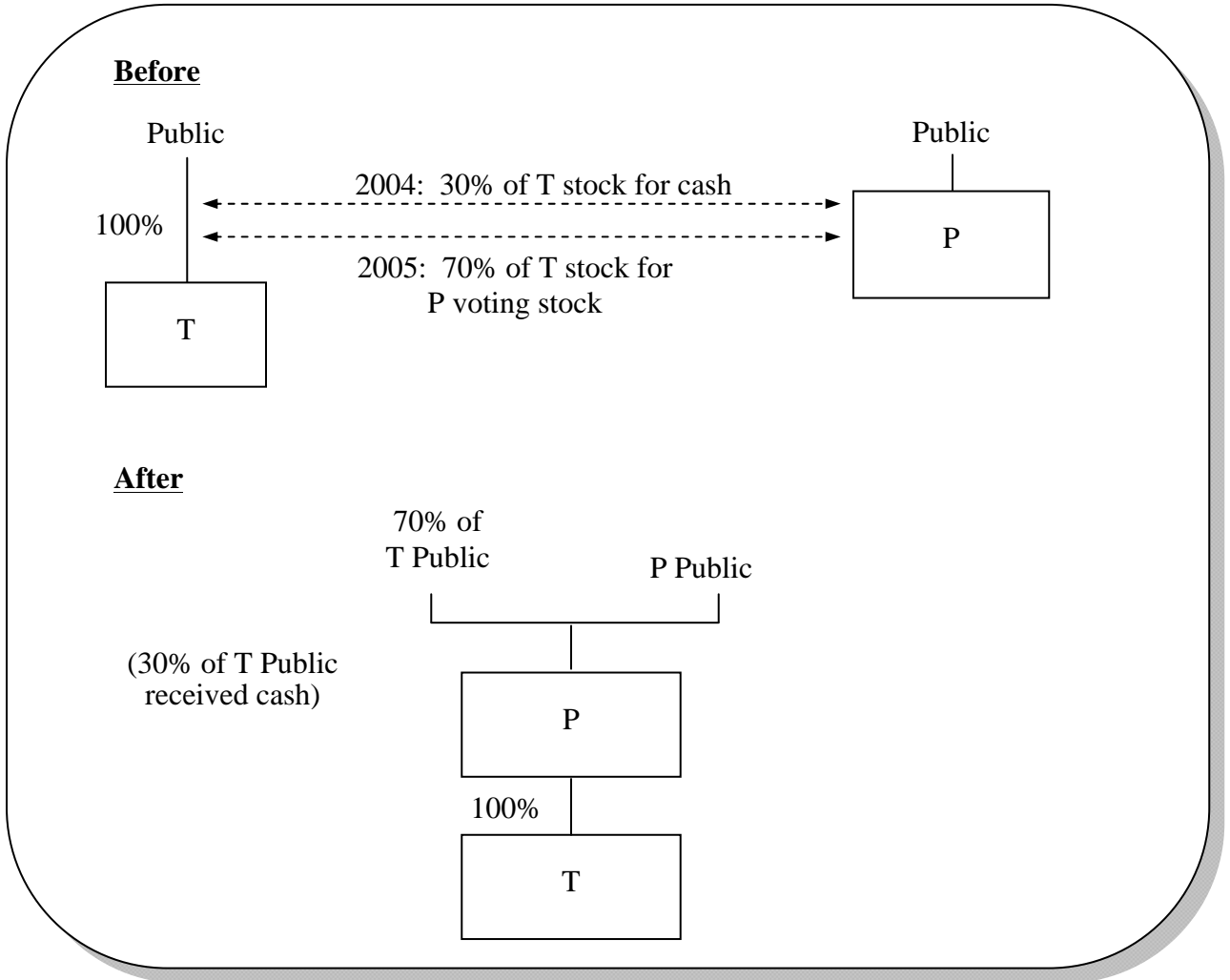

- a. Facts: In 2004, corporation P purchases 30 percent of the stock of corporation T for cash. In 2005, P offers to exchange P voting common stock for the remaining 70 percent of T stock.

b. Issues:

- (1) Must the T shareholders who exchange stock for stock in 2005 recognize gain?

If the two separate steps in the transaction are recognized as independent transactions, then the 2005 transaction should qualify as a “B” reorganization. Although P acquired only 70 percent of the T stock in the exchange, the exchange

was solely in exchange for voting stock (so long as the 2004 transaction can be ignored), and P was in control of T within the meaning of section 368(c) immediately after the exchange. Thus, the two statutory requirements of a “B” reorganization would be met. *But see American Potash & Chem. Co. v. United States*, 399 F.2d 194 (Ct. Cl. 1968).

- (2) If prior to the 2004 exchange, P sells its 30 percent of the T stock to an unrelated third party and then offers to exchange P common stock for T stock the transaction may be able to qualify as a “B” reorganization, provided that at least 80 percent of the T shareholders accept the offer. Rev. Rul. 72-354, 1972-2 C.B. 216.
 - a) However, if there is a tacit agreement between P and the party purchasing the 30 percent interest in T that the exchange offer will be accepted, the Internal Revenue Service may argue that P's attempt to “purge” its pre-existing ownership should fail. *See Chapman v. Commissioner*, 618 F.2d 856 (1st Cir. 1980); *Heverly v. Commissioner*, 621 F.2d 1227 (3rd Cir. 1980).
 - b) Query whether this result is correct. Note that if P sells the 30 percent interest in T for cash and then reacquires the same T stock using P stock, P's cash position is the same as if the T stock had originally been acquired for P stock.

6. Example 6 -- Rev. Rul. 67-274

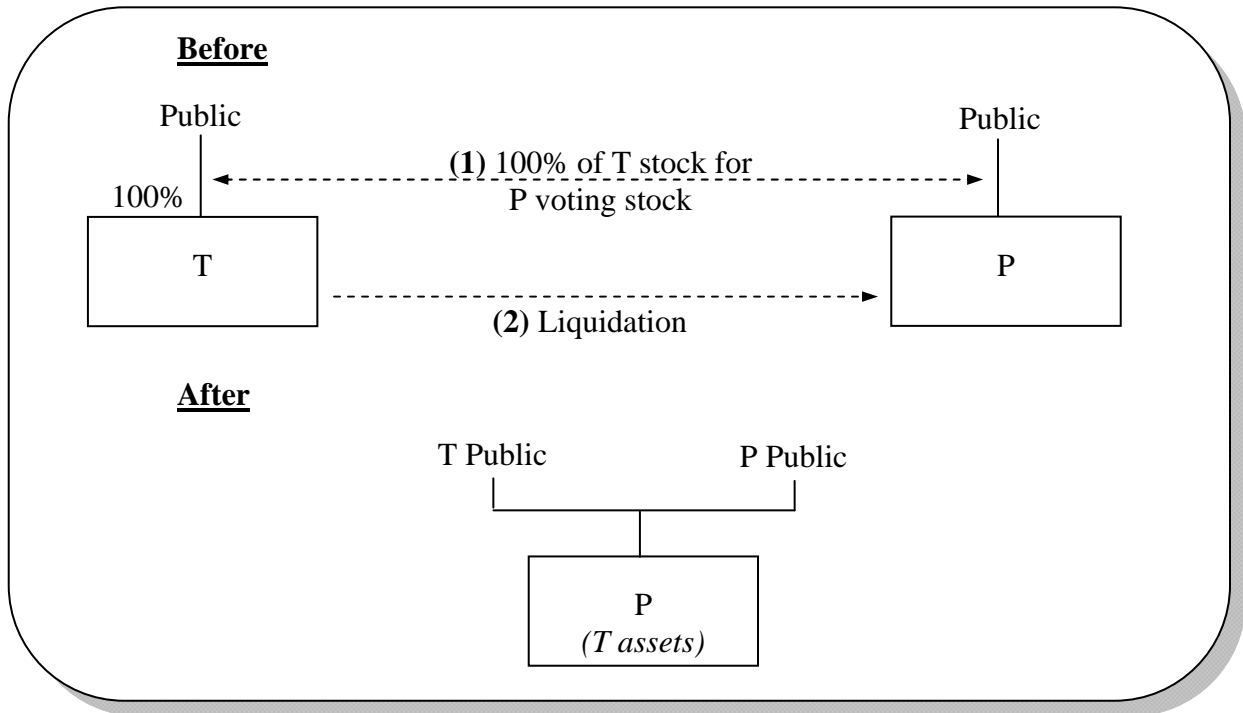

- a. Facts: The shareholders of T exchange all of their T stock for voting stock of P. Immediately following the exchange, and as part of the overall plan, P causes T to liquidate.
- b. Issues: The Service ruled that this transaction should not be treated as a “B” reorganization followed by a liquidation, but instead as a “C” reorganization. Rev. Rul. 67-274, 1967-2 C.B. 141. The rationale for this ruling is that when the transaction is viewed as a whole, P has acquired the assets of T in exchange for voting stock. See also Rev. Rul. 2001-46 2001-2 C.B. 321, discussed *infra*.

7. Example 7 -- Rev. Rul. 2001-24

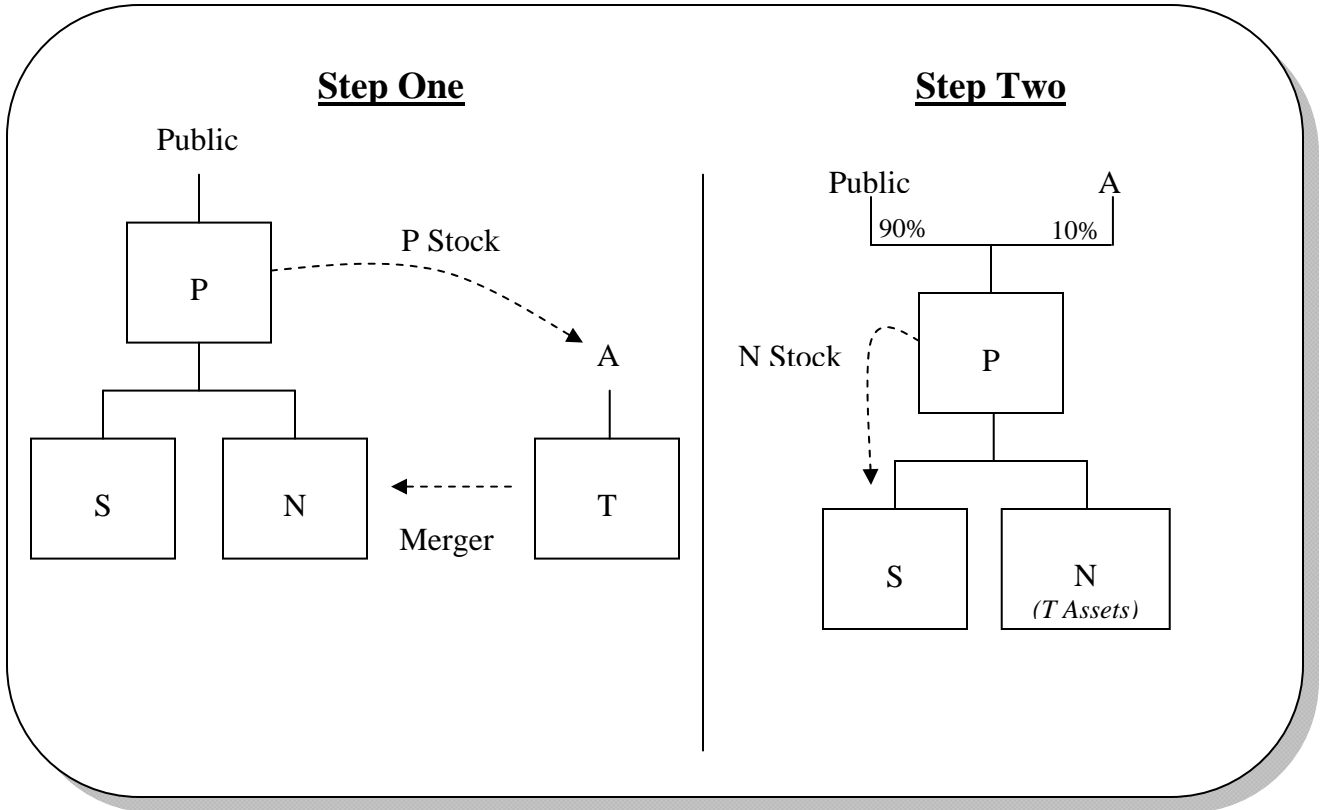

- a. Facts: P owns 100 percent of the stock of S. P wants to acquire T, a corporation owned 100 percent by individual A, and operate it as a subsidiary of S, but wants to make the acquisition using P stock. P forms N, a wholly-owned subsidiary, and T is merged into N, with A receiving 10 percent of the stock of P in the transaction. P then contributes stock of N to S, P's pre-existing wholly owned subsidiary.
- b. Issues:
- (1) The merger of T into N for P stock is a transaction described in section 368(a)(2)(D).
 - (2) Section 368(a)(2)(C) permits the drop-down of acquired assets in an "A", "C" or "G" reorganization, and the drop-down of acquired stock in a "B" reorganization. However, nothing in the statute or regulations directly addresses the drop-down of the stock of a surviving corporation in a section 368(a)(2)(D) triangular merger.
 - (3) Notice that the net effect of this transaction is the acquisition of assets by N in exchange for stock of P, which ends up as its grandparent. If that structure were

undertaken directly, the transaction would not qualify as a reorganization under section 368.

- (4) However, the Service ruled that this merger is a valid reorganization. Rev. Rul. 2001-24, 2001-1 C.B. 1290. *See also* PLRs 9117069 (Nov. 2, 1990) and 9406021 (Nov. 15, 1993).
 - a) Nearly the same result could be reached through a triangular "B" reorganization followed by a dropdown of the acquired stock, which is explicitly permitted by the statute.
 - b) A dropdown of target stock acquired in a reverse triangular reorganization under section 368(a)(2)(E) is specifically contemplated by the regulations. *See* Reg. § 1.368-2(j)(4).
- (5) On Oct. 25, 2007, the Service and Treasury issued final regulations providing that a transaction otherwise qualifying as a reorganization under section 368(a) will not be disqualified as a result of the transfer or successive transfers of assets or stock, provided that the COBE requirement is satisfied and the transfers qualify as distributions or other transfers. Treas. Reg. 1.368-2(k).

8. Example 8 -- Rev. Rul. 2002-85

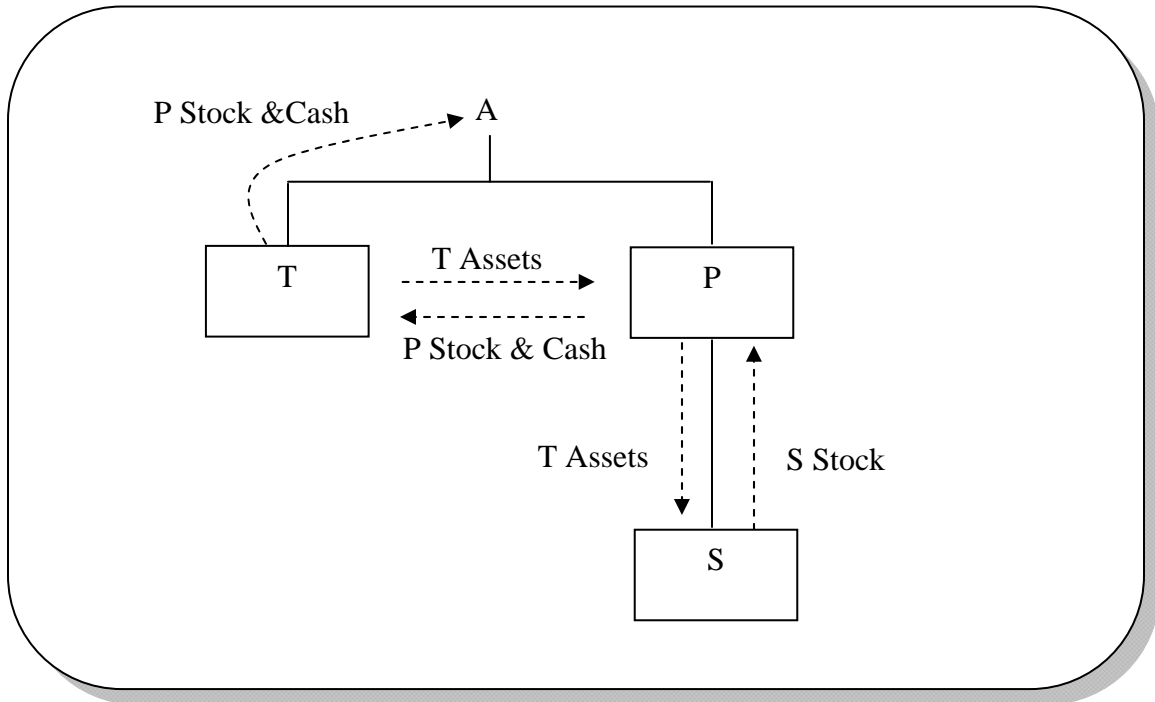

a. Facts: A, an individual, owns 100 percent of T, a state X corporation. A also owns 100 percent of P, a state Y corporation. First, pursuant to plan of reorganization, T transfers all of its assets to P in exchange for consideration consisting of 70 percent P voting stock and 30 percent cash. Second, T liquidates, distributing the P voting stock and cash to A. Third, P transfers all of the T assets to S, a preexisting, wholly owned subsidiary of P, in exchange for S stock.

b. Issues:

(1) Section 368(a)(2)(C) permits the drop-down of acquired assets in an "A", "C" or "G" reorganization, and the drop-down of acquired stock in a "B" reorganization. However, nothing in the statute or regulations directly addresses the drop-down of assets in a "D" reorganization.

(2) In Rev. Rul. 2002-85, 2002-2 C.B. 986, the Service ruled that the merger of T into P qualified as a "D" reorganization even though P did not retain the assets of T.

a) The Service noted that in Rev. Rul. 2001-24, 2001-C.B. 1290, it had ruled that the drop-down of stock of a surviving corporation in a section 368(a)(2)(D) triangular merger was not prohibited by section

368(a)(2)(C) even though section 368(a)(2)(C) did not explicitly allow the drop-down of surviving corporation stock following a section 368(a)(2)(D) triangular merger. In Rev. Rul. 2001-24 the Service had stated that the language of section 368(a)(2)(C) was permissive, rather than restrictive or exclusive and therefore did not prevent the Service from finding that a triangular merger followed by the drop-down of surviving corporation stock to a subsidiary of the acquiror following the transaction was a valid section 368(a)(2)(D) reorganization.

- b) The Service applied the same rationale to the facts of Rev. Rul. 2002-85. The Service stated that sections 368(a)(2)(A) and 368(a)(2)(C) were permissive, not restrictive or exclusive, statutes. Thus, such statutes did not prevent the Service from ruling that a transaction qualified as a “D” reorganization where all of the requirements for a “D” reorganization were otherwise met, but the acquiring corporation dropped acquired assets down to a controlled subsidiary.
- c) Accordingly, the Service stated that an acquiring corporation's transfer of assets to a controlled subsidiary following a transaction that otherwise qualifies as a “D” reorganization will not cause the transaction to no longer qualify as a “D” reorganization, provided that the following requirements are met:
 - i) The original transferee is treated as acquiring substantially all of the assets of the target corporation;
 - ii) The transaction satisfies the Continuity of Business Enterprise requirement and does not fail under the remote continuity principle of *Groman v. Commissioner*, 302 U.S. 82 (1937) and *Helvering v. Bashford*, 302 U.S. 454 (1938); and
 - iii) The transfer of acquired assets to the controlled subsidiary does not prevent the original transferee from being a party to the reorganization.

- iv) In addition, the Service stated that it was considering amending regulations under sections 368 to reflect the principles of Rev. Rul. 2002-85. Presumably, the Service was referring to Treas. Reg. § 1.368-2(k).
- (3) Note that if the Service had stepped together T's transfer of its assets to P and P's drop-down of T's assets to S, the transfer of assets to P by T would have been disregarded as a transitory step. Accordingly, the transaction would have been treated as a direct transfer of T assets to S.
- a) A direct transfer of assets to S by T would not have qualified as a "D" reorganization since section 368(a) does not provide for triangular "D" reorganizations.
 - b) The stepped together transaction also would not have qualified as a "C" reorganization since the amount of boot (the cash) received by T would have exceeded the amount of boot allowed under section 368(a)(1)(C).
 - c) The stepped together transaction may have satisfied the requirements of sections 368(a)(1)(A) and 368(a)(1)(D), provided that it was a statutory merger.
- (4) On Oct. 25, 2007, the Service and Treasury issued final regulations providing that a transaction otherwise qualifying as a reorganization under section 368(a) will not be disqualified as a result of the transfer or successive transfers of assets or stock, provided that the COBE requirement is satisfied and the transfers qualify as distributions or other transfers. Treas. Reg. 1.368-2(k).

9. Example 9 -- Rev. Rul. 2001-25

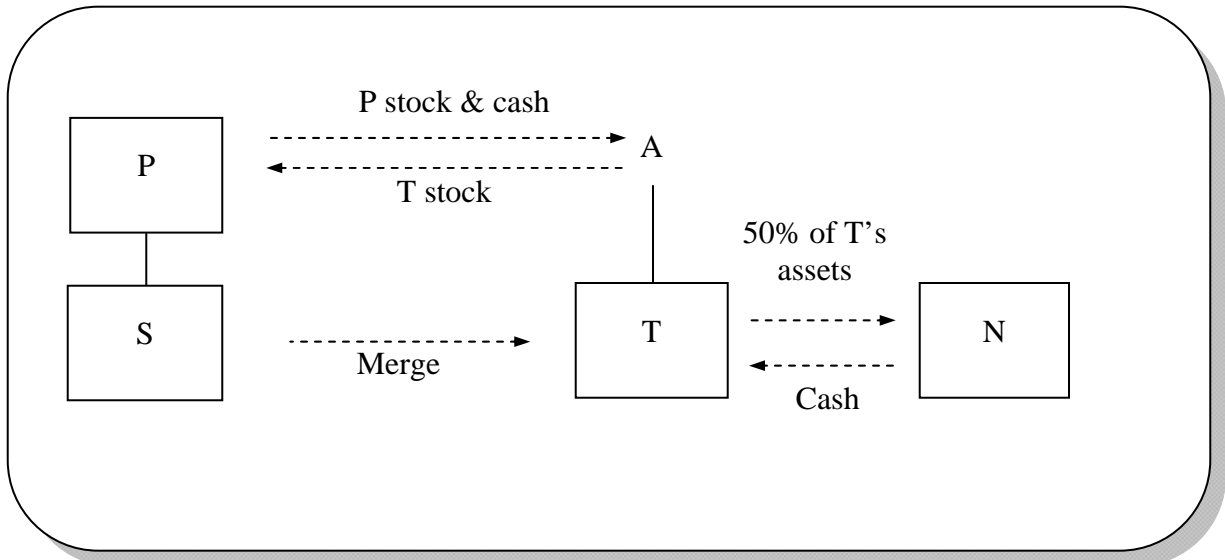

a. Facts: P and T are manufacturing corporations organized under the laws of State A. S, P's newly formed wholly owned subsidiary, merges into T in a statutory merger under the laws of state A. In the merger, P exchanges its voting stock for 90% of the T stock and tenders cash for the remaining 10% of T stock. As part of the merger plan, T sells 50% of its operating assets to X, an unrelated corporation, for cash. T retains the sales proceeds.

b. Issues:

(1) In the case of a reverse subsidiary merger, the surviving subsidiary must hold substantially all the assets of the merged subsidiary and its own assets after the transaction. See section 368(a)(2)(E).

a) Prior to Rev. Rul. 2001-25, 2001-1 C.B. 1291, the Service had indicated that the distribution of acquired assets that caused the surviving subsidiary to hold less than "substantially all" of such assets may disqualify the transaction as a reorganization. See PLRs 9238009 (Mar. 13, 1992), 9025080 (Mar. 28, 1990). See also FSA 199945006 (July 23, 1999) (stating that the assets distributed after a reverse triangular merger pursuant to plan of reorganization will reduce amount of assets treated as held by target after the merger for purposes of determining whether the surviving subsidiary has

held “substantially all” of its own assets and of the merged corporation).

- i) Presumably, this view was based on the requirement that the surviving subsidiary “hold” as opposed to “acquire” substantially all the assets.
 - ii) Yet, the dropdown of stock of the surviving subsidiary or the acquired assets to a controlled subsidiary does not violate this requirement. *See* Treas. Reg. §§ 1.368-2(j)(4), 1.368-1(d).
- b) In Rev. Rul. 2001-25, 2001-1 C.B. 1291, the Service took the view that there was no difference between “acquires” and “holds.”
- i) Specifically the Service stated: “The ‘holds’ requirement of § 368(a)(2)(E) does not impose requirements on the surviving corporation before and after merger that would not have applied had such corporation transferred its properties to another corporation in a reorganization under section § 368(a)(1)(C) or a reorganization under §§ 368(a)(1)(A) and 368(a)(2)(D).” The Service explained that the Code uses the term “holds” rather than “acquisition” because a surviving corporation does not have to “acquire” its own assets.
 - ii) The Service reasoned that because T held the sales proceeds and its other operating assets after the sale, it satisfied the requirement under section 368(a)(2)(E) that the surviving corporation hold substantially all of its properties after the transaction.
- (2) What if instead of selling 50% of its assets, T distributed less than substantially all of its assets to P? Under Prop. Treas. Reg. § 1.368-2(k), the merger of S into T is not disqualified by the transfer of less than substantially all T assets from T to P.

10. Example 10 -- Rev. Rul. 69-617

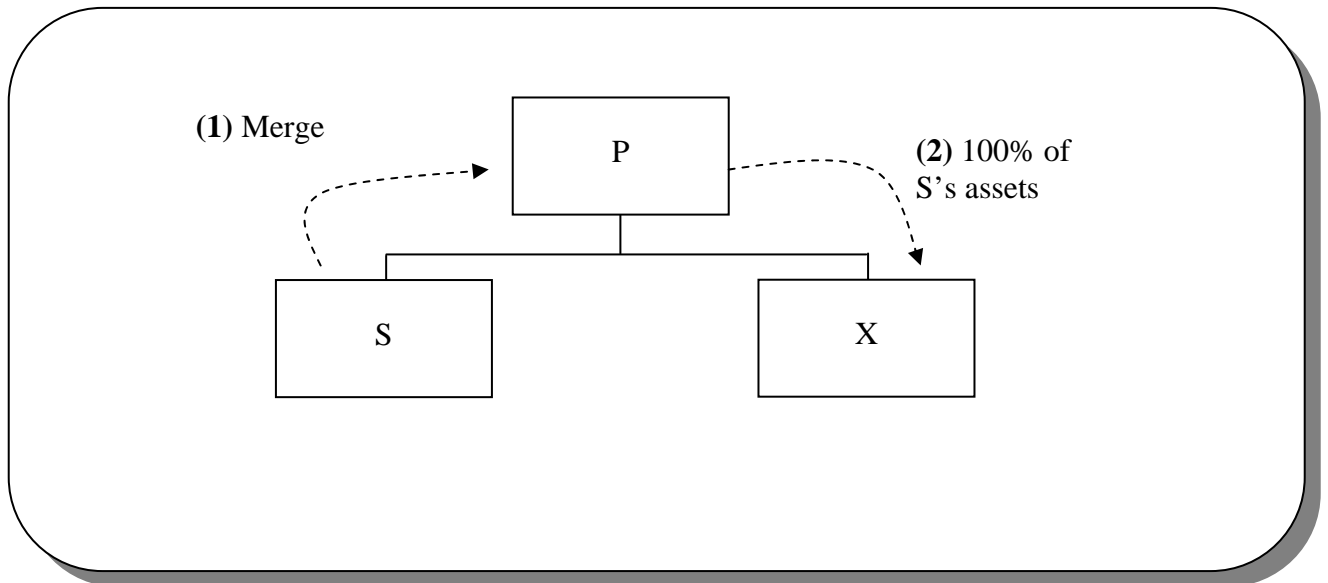

- a. Facts: P owns all of the stock of S and X. P wishes to move S to the X chain. S merges into P pursuant to state law. P then transfers all of the assets received from S to X.
- b. Issues: The Service has ruled that the merger of S into P does not qualify as a liquidation under section 332 because P contributes S's assets to X immediately after the liquidation of S. Thus, this transaction appears to raise "liquidation/reincorporation" issues. Nevertheless, in Rev. Rul. 69-617, 1969-2 C.B. 57, the Service concluded that the merger of S into P followed by the contribution of S's assets to X qualifies as a merger under section 368(a)(1)(A) followed by a tax-free drop-down of assets under section 368(a)(2)(C).

c. Variation -- P transfers less than all of S's Assets to X:

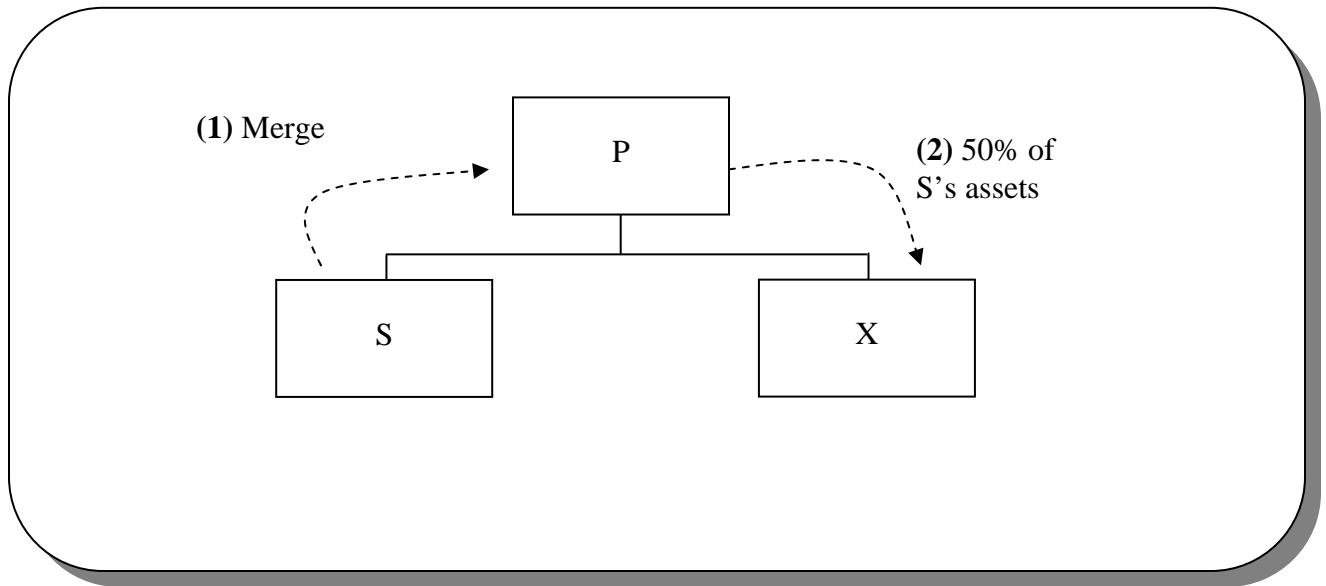

- (1) Facts: Same facts as above except that P contributes 50 percent (rather than 100 percent) of S's assets to X.
- (2) Issues: The Service, relying on Rev. Rul. 69-617, has treated this transaction as a merger under section 368(a)(1)(A) followed by a tax-free drop-down of assets under section 368(a)(2)(C). *See, e.g.*, P.L.R. 9222059 (June 13, 1991); P.L.R. 9422057 (Mar. 11, 1994); P.L.R. 8710067 (Dec. 10, 1986).

11. Example 11 -- Bausch & Lomb and Treas. Reg. § 1.368-2(d)(4)

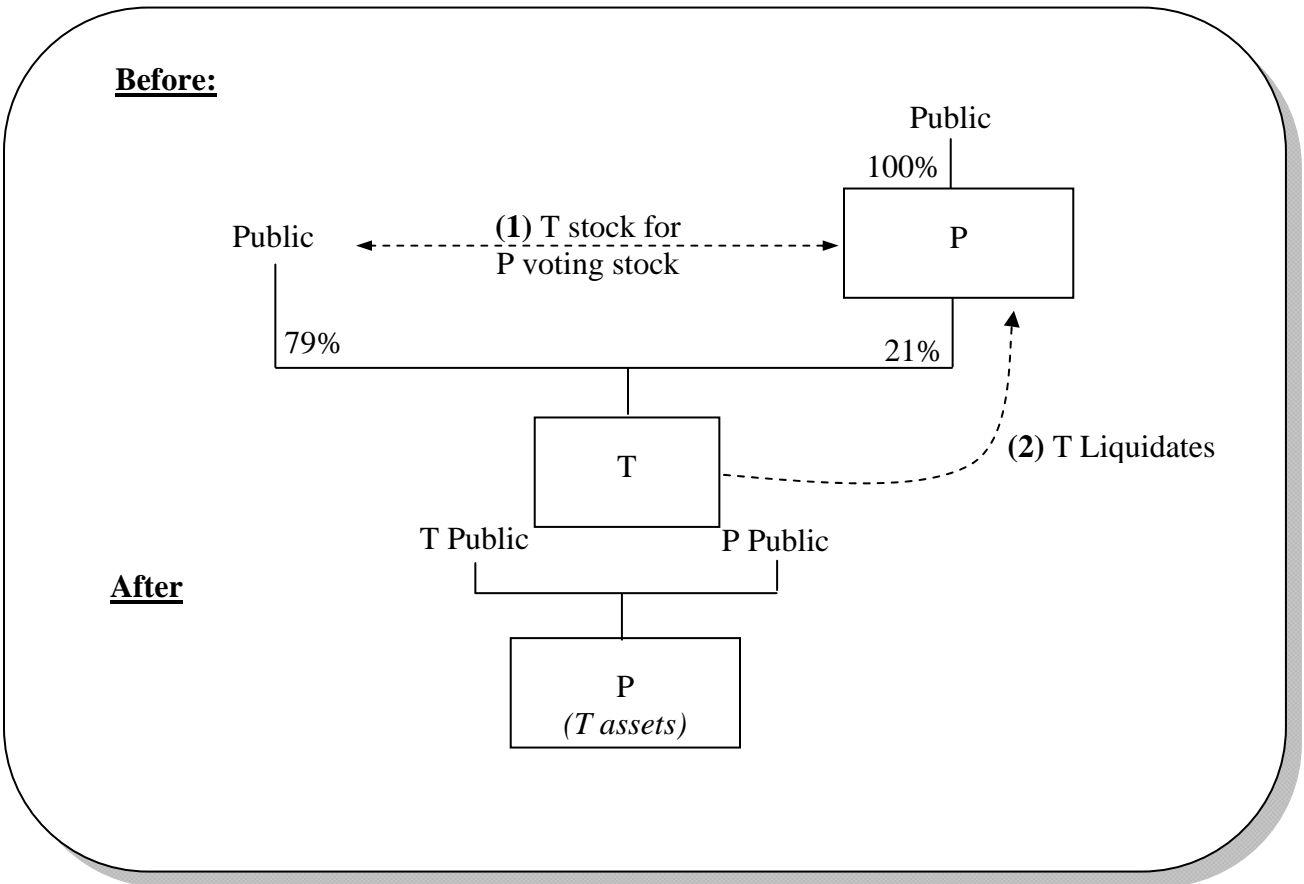

- a. Facts: Same facts as Example 6, except that prior to the transaction, P owned 21 percent of the stock of T.
- b. Issues:
- (1) The recharacterization required by Rev. Rul. 67-274 could transform a tax-free transaction into a taxable transaction under these facts. However, on May 18, 2000, the Service issued final regulations that allow this transaction to qualify as a tax-free reorganization. See T.D. 8885, 2000-1 C.B. 1260; Treas. Reg. § 1.368-2(d)(4). The final regulations reverse the Service’s long-standing position that the “solely for voting stock” requirement of section 368(a)(1)(C) would not be met under these facts. The Service’s former position was upheld in *Bausch & Lomb Optical Co. v. Commissioner*, 267 F.2d 75 (2d Cir. 1959), cert. denied, 361 U.S. 835 (1959). The Second Circuit held in *Bausch & Lomb* that the transaction did not qualify as a “C” reorganization because P was not viewed as acquiring T’s assets solely for P voting stock. Instead a portion of the assets were deemed to be acquired in exchange for the T

stock already owned by P. As a result, the transaction was treated as a taxable liquidation with gain being recognized by T, P, and the shareholders of T.

- (2) Under the final regulations, an acquiring corporation's preexisting ownership of a target corporation's stock generally will not prevent the "solely for voting stock" requirement from being satisfied.
 - (a) In order for section 368(a)(1)(C) to apply, the sum of (i) the money or other property that is distributed to the shareholders of the target corporation other than the acquiring corporation and to the creditors of the target corporation, and (ii) the assumption of all the liabilities of the target corporation (including liabilities to which the properties of the target corporation are subject), cannot exceed 20 percent of the value of all of the properties of the target corporation. *See* section 368(a)(2)(B); Treas. Reg. § 1.368-2(d)(4).
 - (b) The final regulations also provide that if, in connection with a potential "C" reorganization, the acquiring corporation acquires the target corporation's stock for consideration other than its own voting stock or its parent's voting stock, such consideration will be treated as money or other property exchanged by the acquiring corporation for the target corporation's assets. Accordingly, the requirements of section 368(a)(1)(C) will not be satisfied unless the transaction can qualify under the boot relaxation rule of section 368(a)(2)(B), taking into account such money or other property.
 - (c) The Preamble also states that the Service and the Treasury Department may reconsider Rev. Rul. 69-294, 1969-1 C.B. 110, in light of the final regulations. Rev. Rul. 69-294 applied the *Bausch & Lomb* doctrine to disqualify an attempted section 368(a)(1)(B) reorganization that followed a tax-free section 332 liquidation.
 - i) In the ruling, X owned all the stock of Y and Y owned 80% of the stock of Z. Y completely liquidated into X. As planned, X then acquired the remaining 20% of the stock of Z in exchange for X voting stock.

- c. The Service ruled that X did not acquire Z through a “B” reorganization. The Service reasoned that X really acquired 80% of the stock of Z in exchange for surrendering Y stock back to Y in liquidation. Thus, X did not acquire 80% stock of Z by exchanging its own stock, and consequently failed the solely for voting stock requirement of section 368(a)(1)(B).
- d. Variation -- S Liquidates Into P:

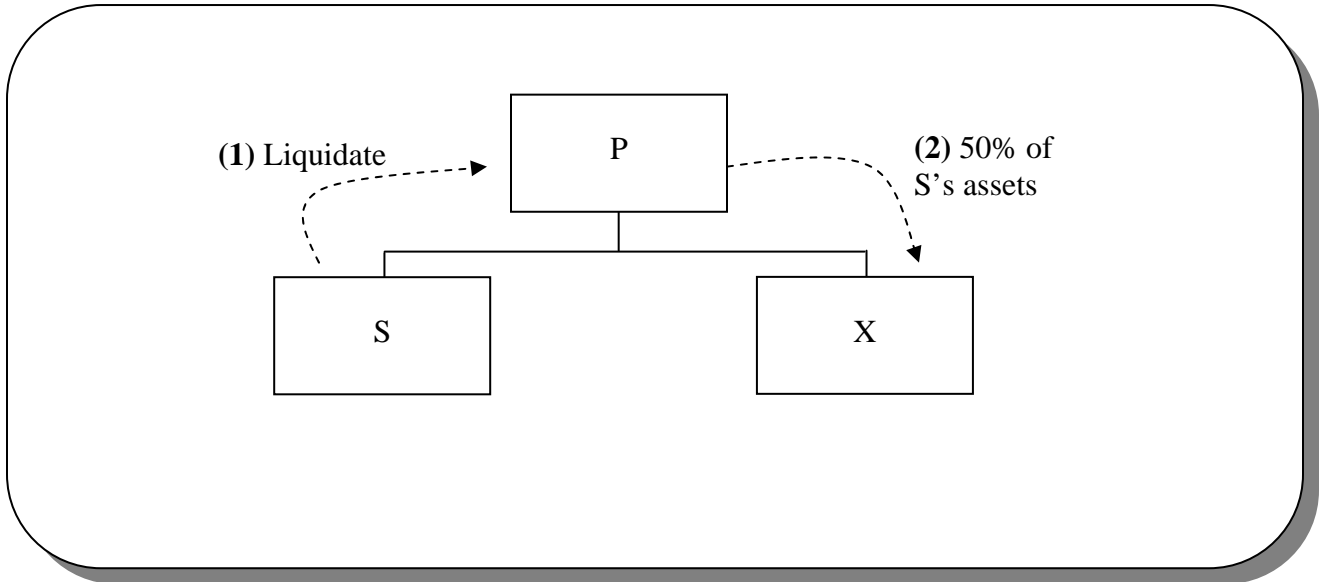

- (1) Same facts as above except that S liquidates, distributing all of its assets to P. P then transfers some of the assets received from S to X.
- (2) Issues: This transaction appears to constitute an upstream “C” reorganization followed by a drop of assets under Section 368(a)(2)(C). See Treas. Reg. § 1.368-2(d)(4) (the “*Bausch & Lomb* Regulations”) *supra*. The *Bausch & Lomb* Regulations provide that “prior ownership of stock of the target corporation by an acquiring corporation will not by itself prevent the solely for voting sock requirement [of section 368(a)(1)(C)] . . . from being satisfied.” Treas. Reg. § 1.368-2(d)(4).

e. Variation -- S Merges Into an LLC and P Contributes S's Assets to Three Different Subsidiaries

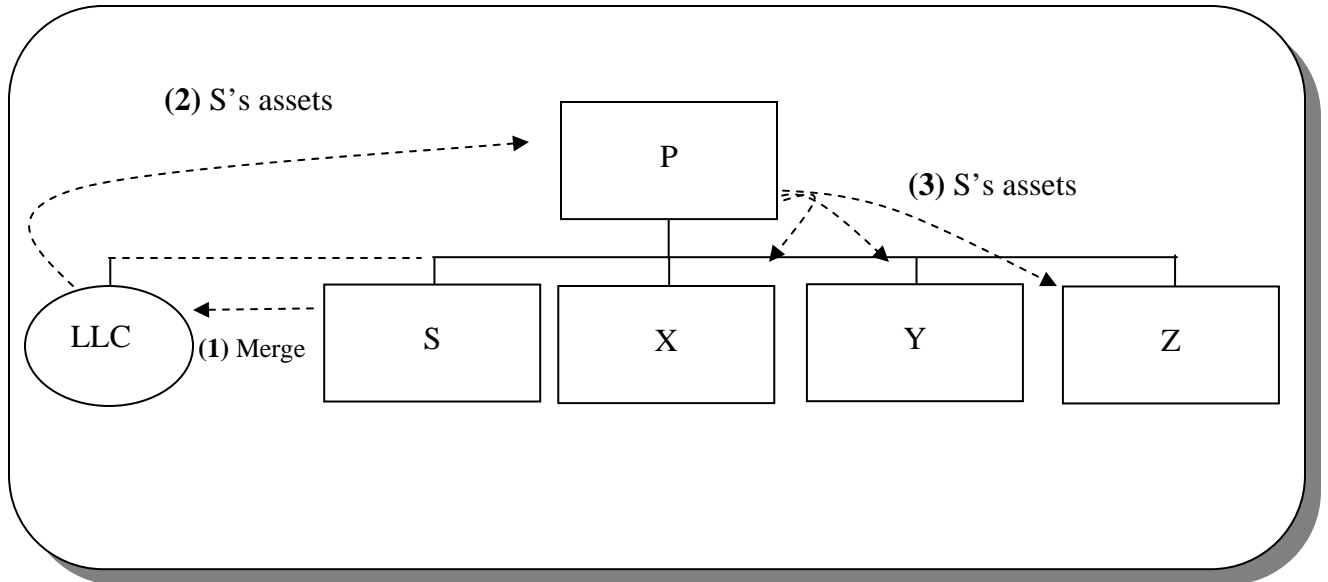

- (1) Facts: P owns all the stock of S, X, Y, and Z. S merges into LLC, an entity newly formed by P (or S converts to an LLC under state law pursuant to a state conversion statute). LLC then distributes all of S's assets to P, which contributes them to X, Y, and Z (or LLC transfers those assets directly to X, Y, and Z).
- (2) Issues: This transaction appears to constitute an upstream "C" reorganization followed by a drop of assets under Section 368(a)(2)(C). See the *Bausch & Lomb* Regulations.

12. Example 12 -- Asset Push-up After Triangular “C” Reorganization

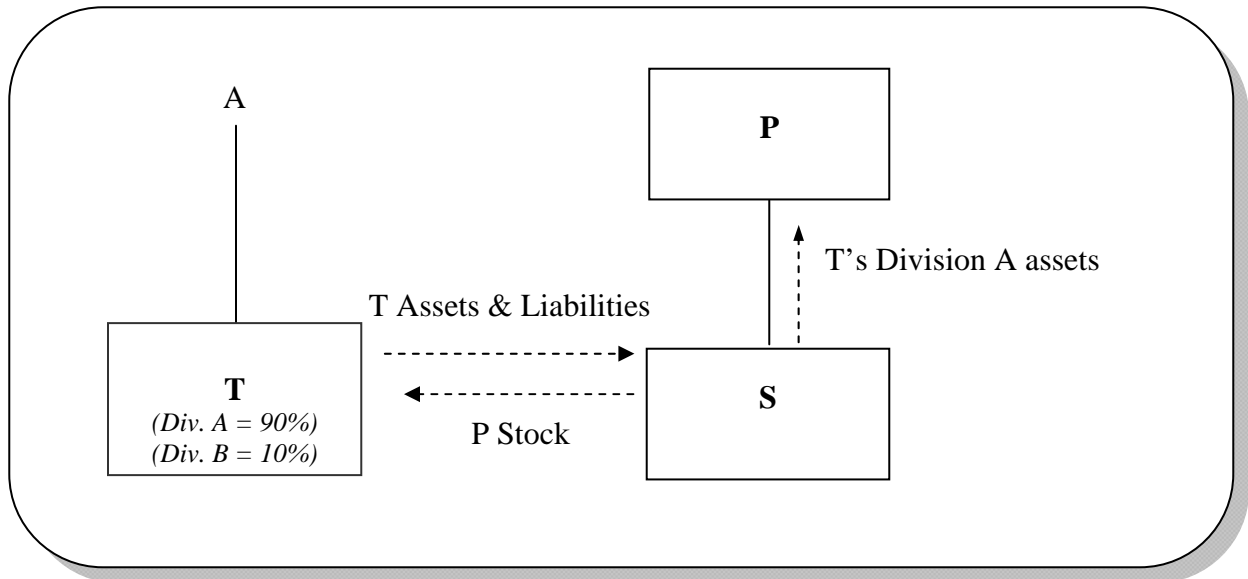

a. Facts: T corporation operates two divisions, Division A (which represents 90% of the value of T's assets) and Division B (which represents 10% of the value of T's assets). Pursuant to a plan to acquire T, (i) P forms S; (ii) T transfers all of its assets to S in exchange solely for voting common stock of P; (iii) S assumes T's liabilities; (iv) T liquidates, distributing P stock to its shareholders; and (v) pursuant to the plan of reorganization, S distributes the Division A assets to P.

b. Issues: Does the distribution of acquired assets affect the initial acquisition?

(1) Under the COBE regulations, in the context of triangular “C” reorganizations, the corporation in control of the acquiring corporation is treated as the “issuing” corporation. Treas. Reg. § 1.368-1(b). Thus, P is the issuing corporation, and the COBE requirement is satisfied as P holds the Division A assets directly and is treated as holding all the assets of S (*i.e.*, the Division B assets). *See* Reg. § 1.368-1(d)(4).

a) Prior to the issuance of the COBE regulations in 1998, it was unclear whether the COBE requirement was satisfied under the above facts. However, the Service had indicated that in the case of pure holding company structures, the business of operating subsidiaries could be attributed to the holding company. *See* Rev. Rul. 85-197, 1985-2

C.B. 120 and Rev. Rul. 85-198, 1985-2 C.B. 120; *see also* PLR 9406005 (Nov. 9, 1993).

- b) Accordingly, the fact that a portion of the business is subsequently conducted directly by the holding company rather than indirectly would not threaten business continuity on these facts.
- (2) It is unclear whether the “solely for voting stock” requirement is met. On similar facts, the Service has ruled that P rather than S will be treated as the “acquiring corporation,” in accordance with the substance of the transaction. *See* G.C.M. 37905 (Mar. 29, 1979); *but see* G.C.M. 36111 (Dec. 18, 1974).
- a) If P is treated as the “acquiring corporation,” liabilities assumed by S will be taken into account for purposes of determining whether the acquisition is solely in exchange for voting stock. *See* section 368(a)(1)(C). Therefore, the transaction may fail to qualify as a “C” reorganization.
 - b) By contrast, where assets are transferred by the acquiring corporation to a subsidiary, the Service respects the form chosen by the taxpayer, based on the statutory language in section 368(a)(2)(C). *See also* G.C.M. 39102 (Dec. 21, 1983).
 - c) Presumably, if P is in substance the “acquiring corporation” and P assumes the Division A liabilities, these liabilities would not be taken into account as boot. However, the transaction may nevertheless fail to qualify as a “C” reorganization if the Division B liabilities assumed by S constitute more than 20 percent of the gross value of the assets acquired (or if P does not assume the Division A liabilities). *See* section 368(a)(2)(B).
 - d) In the case of a forward triangular merger, the acquiring corporation must acquire “substantially all” of the assets of the target. *See* section 368(a)(2)(D).
 - i) It could be argued that, as a result of the distribution of Division A assets to P, S’s transitory acquisition of “substantially all” the assets should be disregarded.

- ii) Nevertheless, the Service has ruled that, subject to other applicable limitations such as the COBE requirement, this transaction qualifies as a reorganization under section 368(a)(2)(D). *See* G.C.M. 36111 (Dec. 18, 1974)(the substantially all requirement looks only to what is transferred by the transferor rather than what is retained by the transferee). *See also* PLR 8747038 (Aug. 25, 1987) (permitting assets acquired in an (a)(2)(D) reorganization to be distributed among members of the acquiring consolidated group.) *Compare Helvering v. Elkhorn Coal*, 95 F.2d 732 (4th Cir. 1937) (where the transferor rather than the transferee distributed property and the transaction was disqualified).
- iii) Similar flexibility exists with respect to the assumption of liabilities. *See* Treas. Reg. § 1.368-2(b)(2) (parent may assume liabilities of target in an “(a)(2)(D)” merger); Rev. Rul. 73-257, 1973-1 C.B. 189 (parent and acquiring subsidiary may both assume such liabilities).

13. Example 13 -- Elkhorn Coal

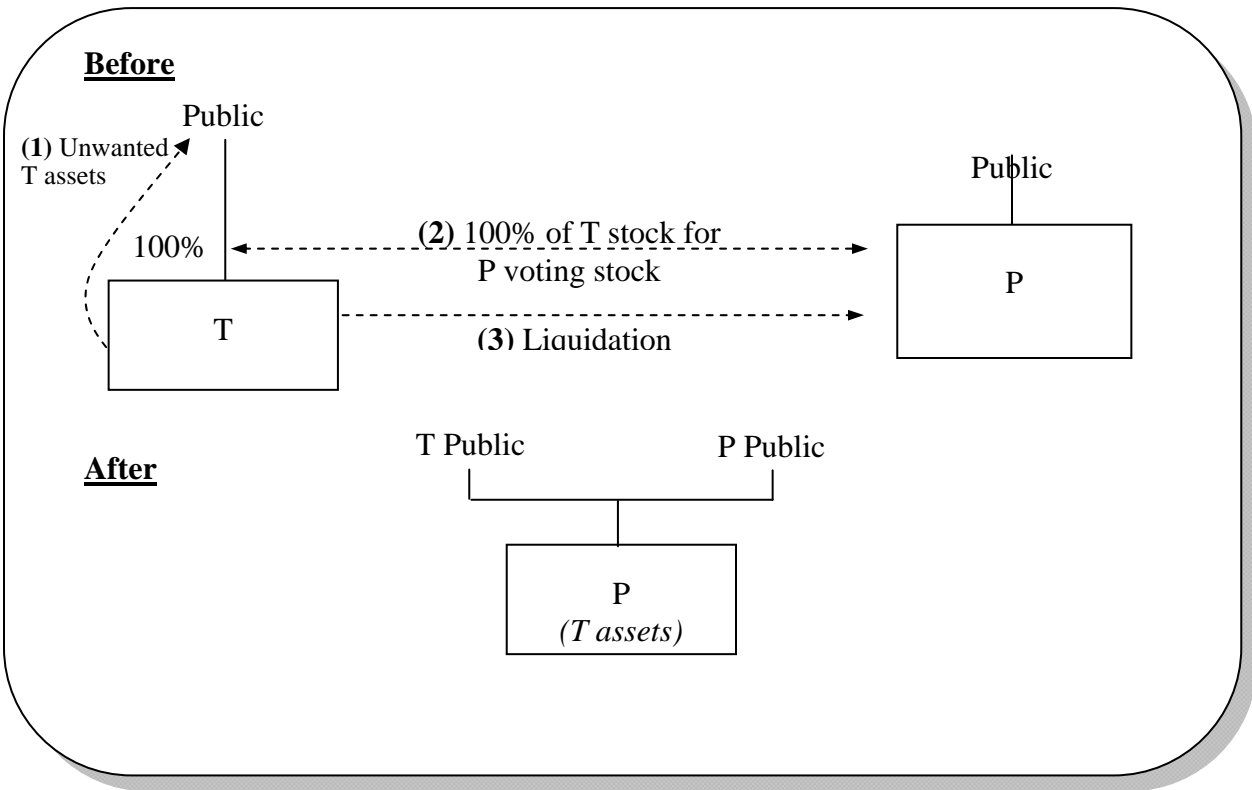

- a. Facts: The shareholders of T agree to exchange all of their T stock for voting stock of P. Prior to the acquisition by P, T distributes unwanted assets to its shareholders in a tax-free transaction under section 355. Immediately following the exchange, and as part of the overall plan, P causes T to liquidate.
- b. Issues: If the transaction is tested as a “C” reorganization under Rev. Rul. 67-274, it would likely fail since P would not be acquiring “substantially all” of T's assets. *Helvering v. Elkhorn Coal Co.*, 95 F.2d 732 (4th Cir. 1937), *cert. denied*, 305 U.S. 605 (1938).

14. Example 14 -- Rev. Rul. 2003-79

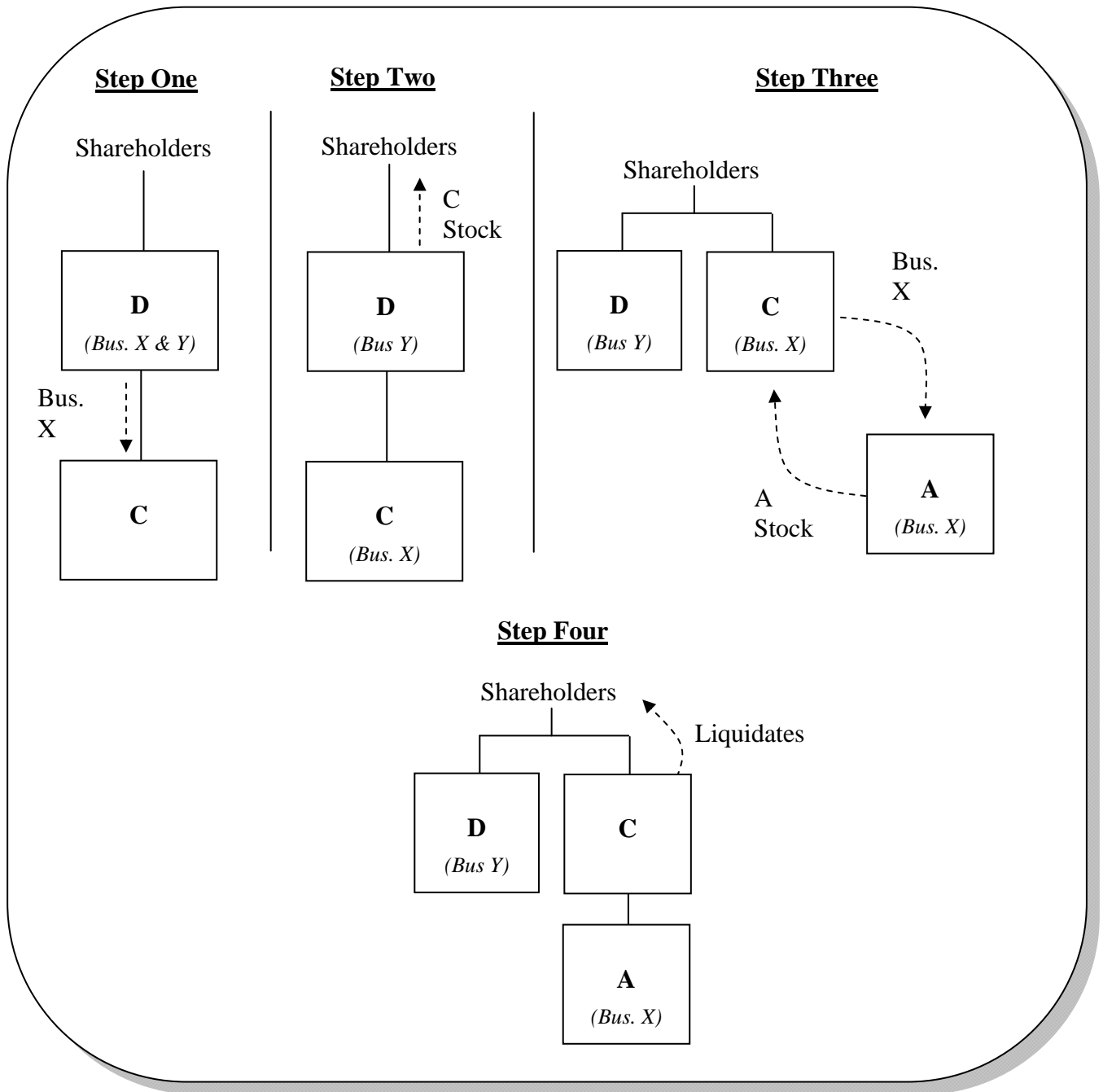

- a. Facts. D directly conducts Businesses X and Y. A conducts Business X and wishes to acquire D's Business X, but not D's Business Y. To accomplish the acquisition, D and A undertake the following steps: (1) D transfers its Business X assets to C, a newly formed corporation, in exchange for 100 percent of the stock of C, (2) D distributes the C stock to D's shareholders, (3) A acquires all the assets of C in exchange solely for voting stock of A, and (4) C liquidates.

b. Issues:

- (1) Apart from the question of whether the acquisition of C's assets by A will satisfy the requirement of section 368(a)(1)(C) that the acquiring corporation acquire substantially all of the properties of the acquired corporation, steps (1) and (2) together meet all the requirements of section 368(a)(1)(D), step (2) meets all the requirements of section 355(a), and steps (3) and (4) together meet all the requirements of section 368(a)(1)(C).
- (2) In Rev. Rul. 2003-79, 2003-2 C.B. 80, the Service ruled that the acquisition of C's assets by A satisfied the substantially all requirement of section 368(a)(1)(C).
- (3) The Service noted that Congress amended section 368(a)(2)(H) in 1998 to provide that "the fact that the shareholders of the distributing corporation dispose of part or all of the distributed stock, or the fact that corporation whose stock was distributed issues additional stock, shall not be taken into account."
- (4) In the Service's view, this amendment evidenced the intention of Congress that a corporation formed in connection with a distribution that qualifies under section 355 will be respected as a separate corporation for purposes of determining (i) whether the corporation was a controlled corporation immediately before the distribution and (ii) whether a pre-distribution transfer of property to the controlled corporation satisfies the requirements of section 368(a)(1)(D) or section 351, even if a post-distribution restructuring causes the controlled corporation to cease to exist.
- (5) As a result, the Service stated that in determining whether an acquiring corporation has acquired substantially all of the properties of a newly formed controlled corporation, reference should be made solely to the properties held by the controlled corporation immediately following the distributing corporation's transfer of properties to it, rather than to the properties held by the distributing corporation immediately before the formation of the controlled corporation.
- (6) The Service, citing *Elkhorn Coal*, acknowledged that if D had distributed Business Y to its shareholders and A had acquired the remaining assets of D from D in a purported "C" reorganization, A would not have been treated as

acquiring substantially all of the assets of D under section 368(a)(1)(C).

15. Example 15 -- Rev. Rul. 96-29

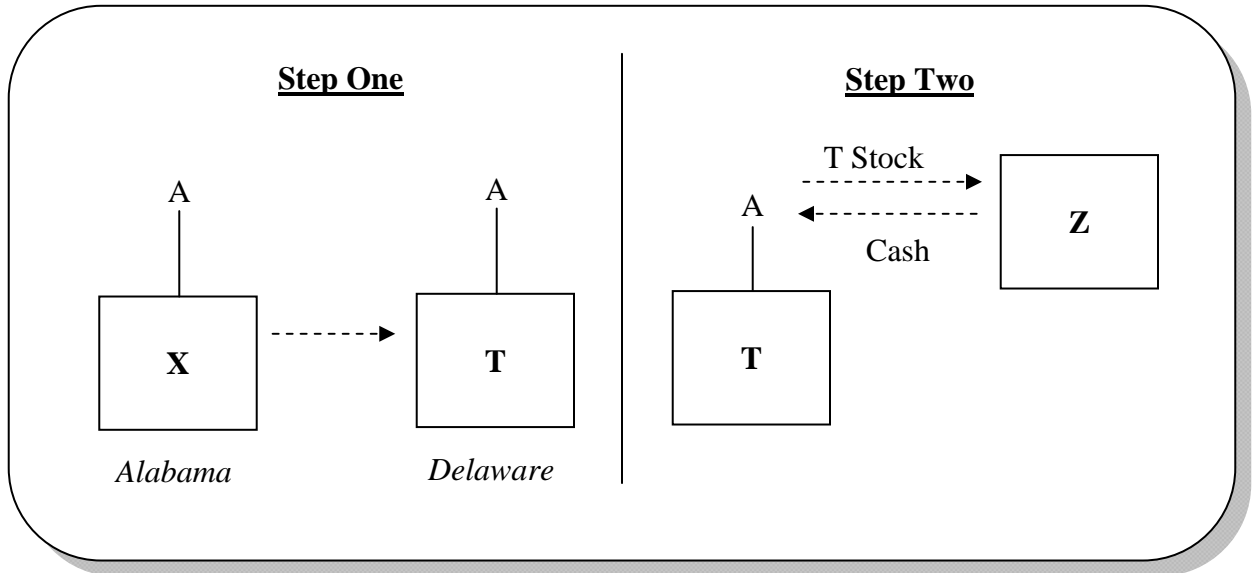

a. Facts: A is the sole shareholder of X, an Alabama corporation. X changes its state of incorporation from Alabama to Delaware and its name from X to T in a reorganization intended to qualify under section 368(a)(1)(F). Immediately after the reorganization, A sells 100% of the T stock to Z for cash.

b. Issues:

(1) The Service has long ruled that an “F” reorganization would not lose its status even if occurring as part of an overall plan involving subsequent tax-free restructurings. *See, e.g.,* Rev. Rul. 96-29; Rev. Rul. 69-516, 1969-2 C.B. 56.

(2) If the transaction subsequent to an “F” reorganization is taxable, the subsequent transaction and the “F” reorganization may be stepped together. For example, if the subsequent transaction is a sale of shares, the “F” reorganization may not satisfy the “continuity of interest” (“COI”) requirement applicable to reorganizations under section 368(a)(1)(F).

a) The COI rules provide that section 368 applies only where a substantial part of the value of the proprietary interests in the target corporation is

preserved. A proprietary interest in the target corporation is preserved if it is exchanged for a proprietary interest in the issuing corporation, it is exchanged by the acquiring corporation for a direct interest in the target corporation enterprise, or it otherwise continues as a proprietary interest in the target corporation. See Treas. Reg. § 1.368-1(e)(1). Conversely, the regulations provide that a proprietary interest is not preserved in the target corporation where, in connection with a potential reorganization, a person “related” to the issuer acquires, with consideration other than issuer stock, stock of the target or stock of the issuer furnished in exchange for the target stock in the reorganization. Treas. Reg. § 1.368-1(e)(2).

- b) In general, the issuer corporation is “related” to the target corporation if both corporations are members of an affiliated group (i.e., a common parent owns at least 80% of the vote and value of both corporations). Treas. Reg. § 1.368-1(e)(3)(i)(A). Moreover, a corporation will be treated as related to another corporation if such relationship exists immediately before or immediately after the acquisition of the stock involved. Treas. Reg. § 1.368-1(e)(3)(ii)(A). The Service has indicated in informal discussions that, in its view, the COI requirement has not been satisfied where an otherwise valid “F” reorganization is immediately followed by a taxable sale of shares in the entity resulting from the “F” reorganization.
- (3) This result does not seem consistent with the policy underlying the COI regulations, which were designed to liberalize the COI requirement by looking only to the consideration furnished to the target shareholders in the reorganization. In addition, Rev. Rul. 96-29 supports respecting the “F” reorganization and subsequent disposition of T shares as separate transactions. Finally, in at least one letter ruling, the Service has respected a sale of assets following an “F” reorganization. See P.L.R. 200129024 (April 20, 2001).
 - (4) On August 12, 2004, the Service and Treasury issued proposed regulations stating that the application of the COI requirements to a “F” reorganization is not required to protect the policies underlying the reorganization provisions. See Prop. Treas. Reg. § 1.368-2(m)(2). This

portion of the proposed regulations was issued as a final regulation on Feb. 25, 2005. See Treas. Reg. § 1.368-1(b), T.D. 9182, 70 Fed. Reg. 9219-9220 (Feb. 25, 2005). In addition, the proposed regulations provide that related events that precede or follow a transaction or series of transactions that constitutes a “mere change in corporate form” will not cause that transaction or series of transactions to fail to qualify as a “F” reorganization. Prop. Treas. Reg. § 1.368-2(m)(3)(ii).

16. Example 16 -- King Enterprises

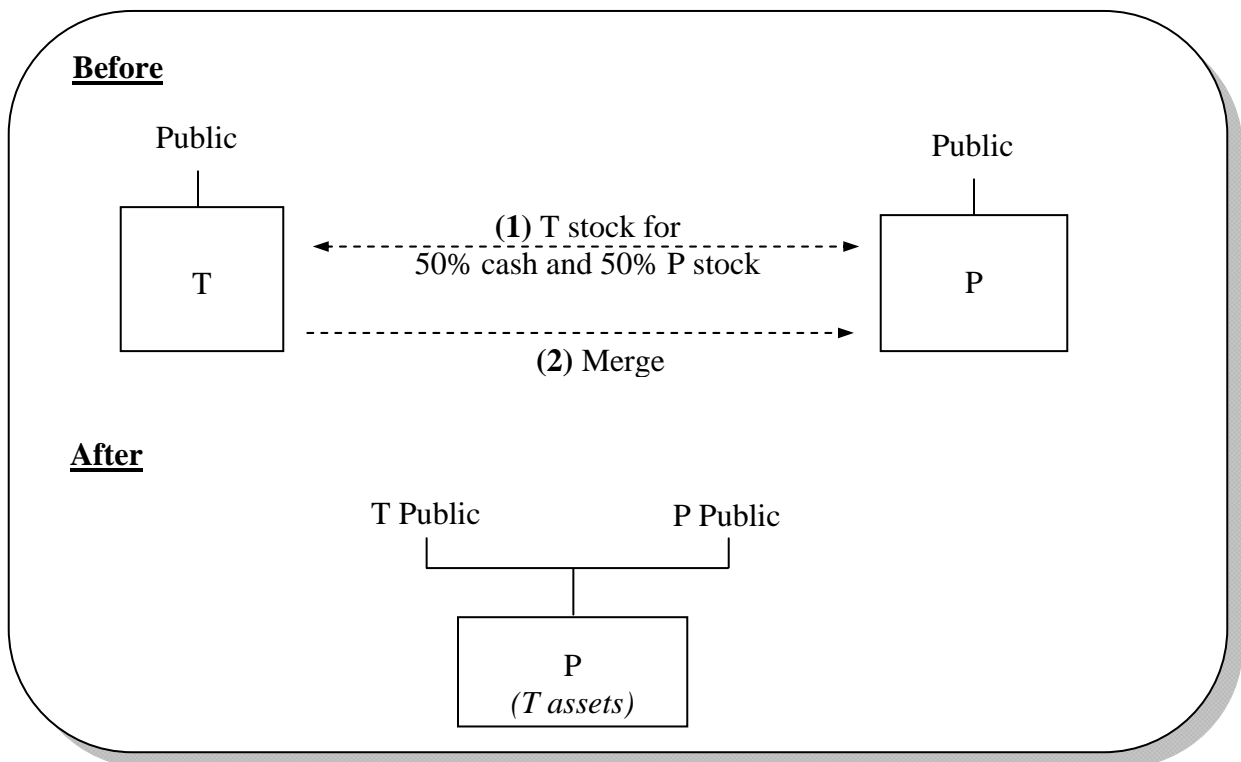

- a. Facts: Same facts as Example 6, except that the consideration used is 50 percent stock and 50 percent boot, and instead of being liquidated, T merges upstream into P.
- b. Issues: The transaction could continue to qualify as an “A” reorganization if T is merged into P. See *King Enterprises, Inc. v. United States*, 418 F.2d 511 (Ct. Cl. 1969).
 - (1) Prior to the issuance of Rev. Rul. 2001-26 and Rev. Rul. 2001-46 (discussed *infra.*), commentators questioned whether *King Enterprises* had any validity following the 1982 amendments to section 338. See Boris I. Bittker & James S. Eustice, *Federal Income Taxation of*

Corporations and Shareholders, ¶ 12.63[2][a] (6th ed. 1994).

- (2) However, with the issuance of these rulings, the Service seems firmly committed to the step transaction principles of *King Enterprises*. See also Brief for the Government, on appeal from the decision of the U.S. Tax Court in *Seagram Corp. v. Commissioner*, 104 T.C. 75 (1995) (citing *King Enterprises* with approval).
 - (3) Assume the same facts, except that P sells T's assets to X, an unrelated third party immediately after the merger of T into P. If treated as an integrated transaction under the rule of the *King Enterprises* case, this transaction will not qualify as a reorganization under section 368(a). It fails the continuity of business requirement because P is not continuing T's business or using T's assets following the merger. Query whether, as a failed reorganization, the steps of this transaction should be integrated under the rule of the *King Enterprises* case or treated as a stock sale followed by a liquidation and sale of assets by P to X. Presumably, because P's purchase of T stock constitutes a qualified stock purchase, the transaction should be treated as a purchase of T stock by P, followed by a separate liquidation of T and sale of T assets to X under the rule of Rev. Rul. 90-95, discussed *infra*.
- c. Variation: Same facts as above, except that P sells T's assets to X, an unrelated party immediately after the merger of T into P. Query whether the step transaction doctrine would apply to combine this additional step with the purchase of T shares and merger of T into P.

d. Variation -- P.L.R. 200114040:

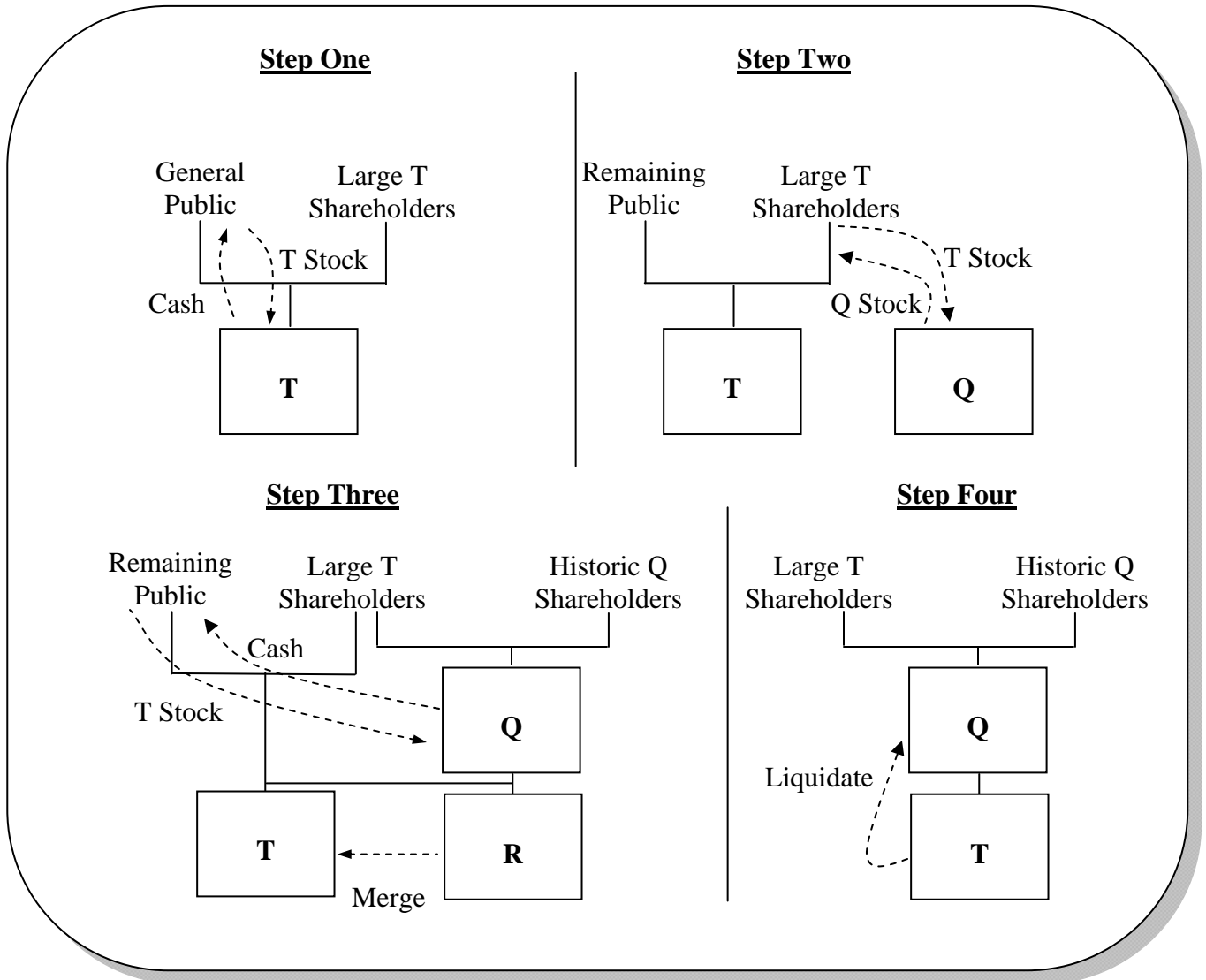

- (1) Facts: T makes a tender offer to all of its shareholder to acquire T stock to increase the percentage ownership of T's largest shareholders. T's largest shareholders contribute T stock to Q solely in exchange for A stock. Q forms wholly-owned subsidiary R that merges into T, with T surviving the merger. All of T's remaining shareholders except A receive cash for T stock as part of the merger. Q makes a Subchapter S election and a QSub election for T, resulting in a deemed liquidation of T.

(2) Issues:

- a) In P.L.R. 200141040 (July 17, 2001), the Service ruled that the four steps described above would be collapsed and treated as the transfer by T of “substantially all” of its assets to Q in exchange for Q stock and the assumption by Q of T’s liabilities, followed by the liquidation of T.
- b) The combined steps qualified as a reorganization under section 368(a)(1)(D).

17. Example 17 -- Yoc Heating

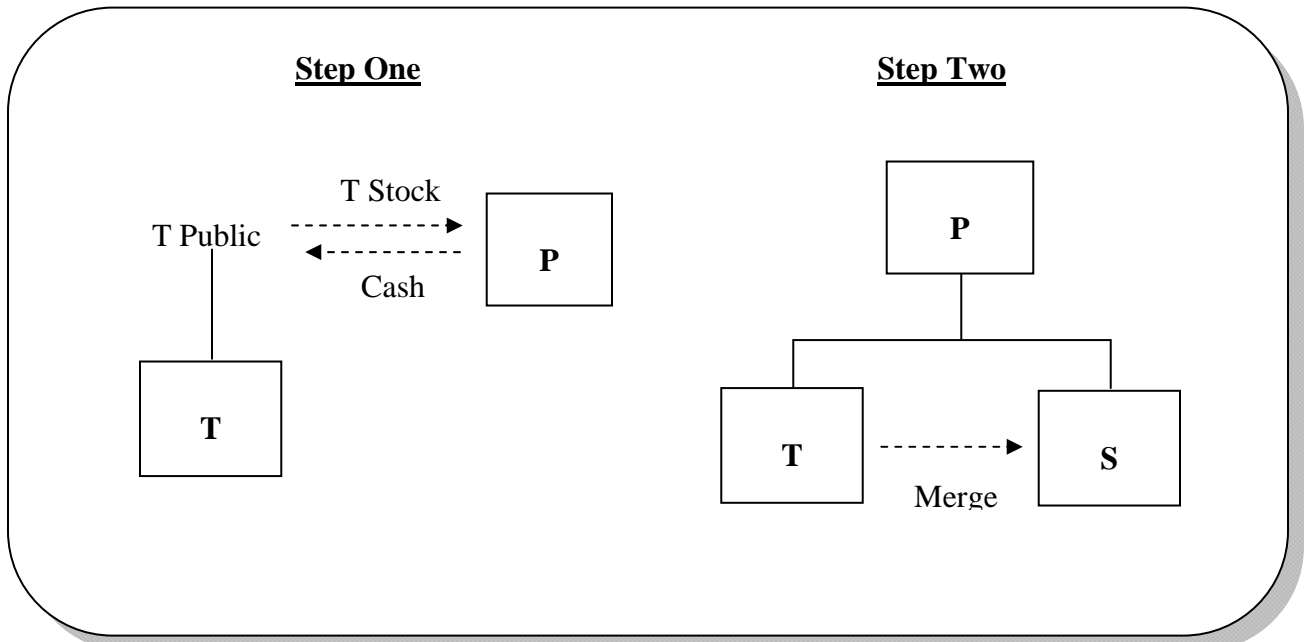

- a. Facts: P purchases 100 percent of the T stock for cash. Immediately following the stock purchase, P causes T to merge into S, a wholly-owned subsidiary of P.

b. Issues:

- (1) In *Yoc Heating Corp. v. Commissioner*, 61 T.C. 168 (1973), the Tax Court held that this transaction failed to qualify as a reorganization because, applying the step transaction doctrine, historic shareholder continuity is not present.
- (2) The Service has rejected the holding of *Yoc Heating* and has issued final regulations that treat the COI requirement

as satisfied in this case where the acquisition of T stock constitutes a qualified stock purchase under section 338, which eliminates the taint of the change in ownership for COI purposes. *See* Treas. Reg. § 1.338-3(d)(2). (On February 12, 2001, the Service issued T.D. 8940, 2001-1 C.B. 1016, supplanting the existing body of temporary section 338 regulations with a new set of final regulations. The new final regulations are in general very similar to the temporary regulations that the Service had issued on January 7, 2000.) *See also* Treas. Reg. § 1.368-1(e)(6), ex. 2 (stating that if P does not acquire the T stock in a qualified stock purchase, the transaction fails the COI requirement). However, these regulations do not extend tax-free treatment to any minority shareholders. *Cf. Kass v. Commissioner*, 60 T.C. 218 (1973), *aff'd*, 491 F.2d 749 (3d Cir. 1974).

- (3) As this example and the preceding examples illustrate, there appears to be a fundamental difference in the Service's treatment of multi-step acquisitions depending on whether the initial acquisition is a qualified stock purchase, or a tax-free reorganization. As noted in Rev. Rul. 2001-46, if the application of the step transaction doctrine to a qualified stock purchase and a subsequent merger or liquidation would allow P to receive a cost basis in the T assets under section 1012 without a section 338 election, the Service will not apply the step transaction doctrine. However, if the application of the step transaction doctrine would result in a tax-free reorganization and no cost-basis in the T assets, the Service will apply the step transaction doctrine.
- (4) The Service's approach in Rev. Rul. 2001-26, discussed *infra*, and Rev. Rul. 2001-46 is appropriate. In general, step transaction principles should apply to determine the nature of the transaction. After the application of these principles, then more specific rules, such as Rev. Rul. 90-95, should be applied (assuming the recharacterized transaction permits such application).

18. Example 18 -- Rev. Rul. 90-95

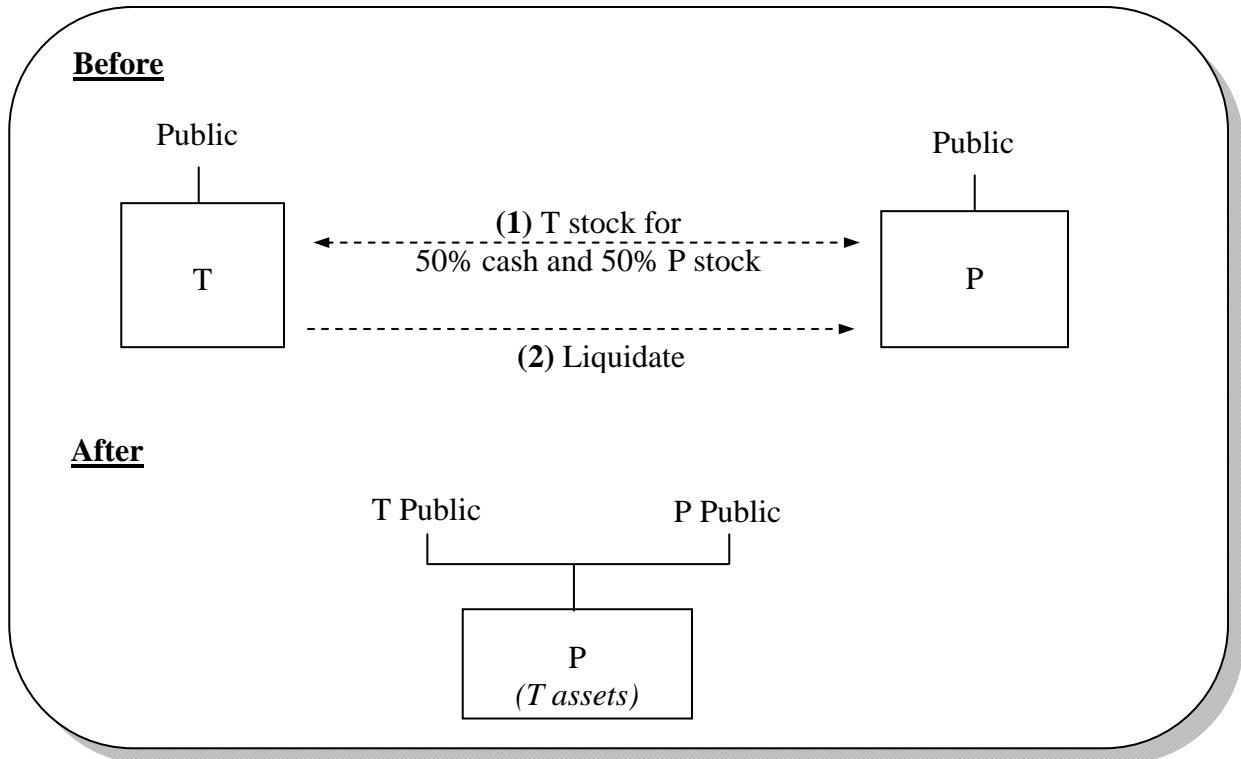

- a. Facts: Same facts as Example 6, except that the T shareholders receive a mixture of 50% cash and 50% P stock in exchange for their T stock.
- b. Issues:
- (1) Clearly the use of cash consideration will cause the transaction to fail as either a “B” or a “C” reorganization.
 - (2) Will the step transaction doctrine apply?
 - a) Under the theory of Rev. Rul. 67-274, the transaction would be viewed as a direct asset acquisition of T's assets for cash, resulting in a stepped-up basis in T's assets.
 - b) However, Rev. Rul. 90-95, 1990-2 C.B. 67, treats a qualified stock purchase, within the meaning of section 338, followed by a liquidation as two separate transactions, reversing the holding of *Kimbell-Diamond Milling Co. v. Commissioner*, 14 T.C. 74, *aff'd per curiam*, 187 F.2d 718 (5th Cir. 1951), *cert. denied*, 342 U.S. 827 (1951). The

rejection of the step transaction doctrine in Rev. Rul. 90-95 was necessary to protect the integrity of section 338 (*i.e.*, the application of the step transaction doctrine under the facts of Rev. Rul. 90-95 would allow P to receive a cost basis in the T assets under section 1012 without a section 338 election).

19. Example 19 -- Rev. Rul. 2001-26

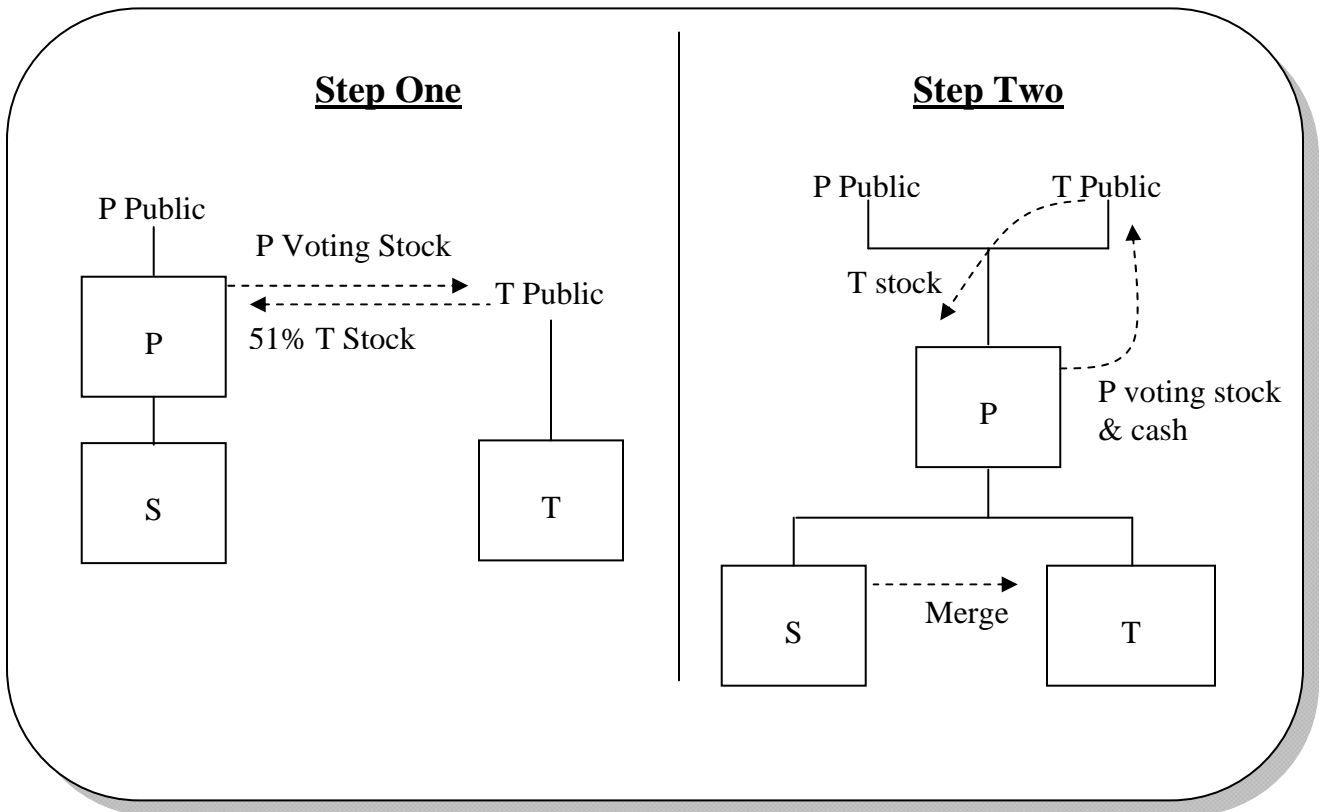

- a. Facts: P and T are widely held manufacturing corporations organized under the laws of state A. T has only voting common stock outstanding, none of which is owned by P. P seeks to acquire all of T's outstanding stock. For valid business reasons, the acquisition will be effected by a tender offer for at least 51% of T's stock, to be acquired solely for P voting stock, followed by a merger of S, P's newly formed wholly owned subsidiary, into T. Pursuant to the tender offer, P acquires 51% of T's stock from T's shareholders for P voting stock. P then forms S, which merges into T in a statutory merger under the laws of state A. In the merger, P's S stock is converted into T stock and each of the T shareholders holding the remaining 49 percent of the outstanding T stock exchanges its shares of T stock for a combination of

consideration, two-thirds of which is P voting stock and one-third of which is cash.

b. Issues: Assuming (i) that the tender offer and merger are treated as an integrated acquisition by P of all of the T stock, and (ii) that all non-statutory requirements under sections 368(a)(1)(A) and 368(a)(2)(E), and all statutory requirements under section 368(a)(2)(E) (other than the requirement that P acquire control of T in exchange for its voting stock) are satisfied, the Service ruled in Rev. Rul. 2001-26, 2001-1 C.B. 1297, that the entire two-step transaction constitutes a tax-free reorganization under sections 368(a)(1)(A) and 368(a)(2)(E). Overall, 83% of the consideration received by T's shareholders for their T stock consisted of P voting stock [$51\% + (2/3 \times 49\%) = 83\%$]. Thus, P satisfied the statutory rule under section 368(a)(2)(E) that required P to acquire control of T (*i.e.*, 80% of T's stock) in exchange for P voting stock.

- (1) The Service's ruling is based on the holding in *King Enterprises* that where a merger is the intended result of a pre-merger stock acquisition, the acquiring corporation's acquisition of the target corporation qualifies as an "A" reorganization. The Service reasoned in Rev. Rul. 2001-26 that because the tender offer is integrated with the statutory merger, *i.e.*, the merger is the intended result of the tender offer, the tender offer is treated as part of the subsequent statutory merger for purposes of the reorganization provisions.
- (2) Assume the same facts, except that S initiates the tender offer for T stock and, in the tender offer, acquires 51% of the T stock for P stock provided by P? Under these facts, the Service ruled that the result would be the same, *i.e.*, that because the merger is the intended result of the tender offer, the tender offer is treated as part of the subsequent statutory merger for purposes of the reorganization provisions, and the transaction constitutes a tax-free reorganization under sections 368(a)(1)(A) and 368(a)(2)(E).

20. Example 20 -- Rev. Rul. 2001-46: Situation 1

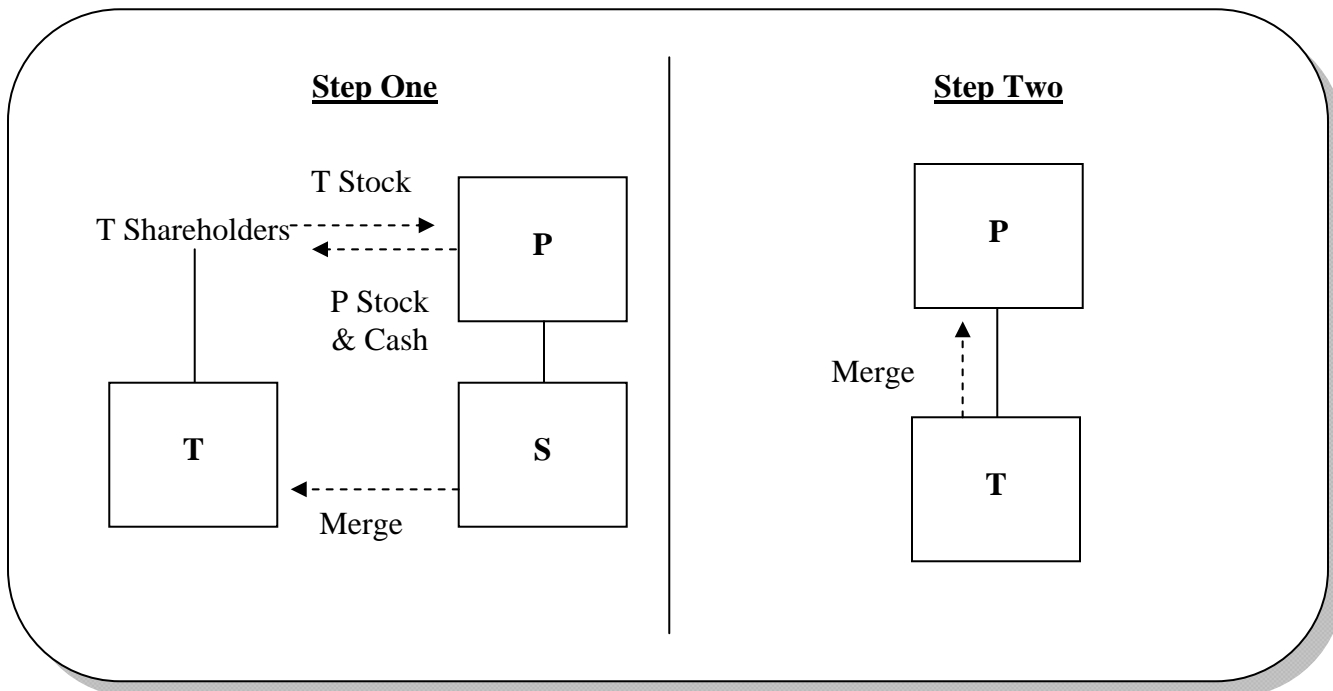

- a. Facts: Pursuant to an integrated plan, P acquires all the stock of T in a reverse subsidiary merger of P's newly formed wholly owned subsidiary, S, into T, with T's shareholders exchanging their stock for consideration of 70% P voting stock and 30% cash. Immediately thereafter, T merges upstream into P.
- b. Issues:
- (1) Will the rationale of Rev. Rul. 67-274 apply to step the two mergers together, or will the rationale of Rev. Rul. 90-95 apply and treat the mergers as independent transactions?
 - (2) In Rev. Rul. 2001-46, 2001-2 C.B. 321, the Service limited the application of Rev. Rul. 90-95 under these facts. The Service ruled that, because the transaction would be treated as a statutory merger of T into P under section 368(a)(1)(A) if the step transaction doctrine applied (and thus P would not receive a cost basis in T's assets under section 1012), the analysis in Rev. Rul. 90-95 is not necessary. Thus, the step transaction doctrine applies, and the transaction should be treated as a merger of T directly into P under section 368(a)(1)(A).
 - (3) Presumably, if the stepped-together transactions in Rev. Rul. 2001-46 had failed to qualify as a reorganization, the rule of Rev. Rul. 90-95 would have applied.

- (4) Assume the same facts as Example 19, except that T is a member of a consolidated group in which it is not the parent. P acquires T's stock for 50 percent P stock and 50 percent cash. P's and T's shareholders agree to make a section 338(h)(10) election. Following the stock purchase, T is merged into P under state corporate law. Query whether Rev. Rul. 2001-46 requires that the section 338(h)(10) election must be ignored and that P must be treated as acquiring T's assets in a reorganization qualifying under section 368(a)(1)(A). Rev. Rul. 2001-46 states that the Service and Treasury are considering whether to issue regulations that would allow taxpayers to make a joint section 338(h)(10) election in circumstances similar to these facts.
- (5) On July 5, 2006, the Service issued final regulations that would permit a taxpayer to turn off the step transaction doctrine and to make a section 338(h)(10) election in the transaction described above. *See* Treas. Reg. § 1.338-3(c)(1)(i), (2) and Treas. Reg. § 1.338(h)(10)-1(e) Ex. 12 & 13.
- a) In general, the regulations provide that the step transaction doctrine will not be applied if a taxpayer makes a valid section 338(h)(1) election with respect to a step in a multi-step transaction, even if the transaction would otherwise qualify as a reorganization, if the step, standing alone, is a qualified stock purchase. *See* Treas. Reg. § 1.338(h)(10)-1(c)(2).
- b) This rule would apply to the transaction above regardless of whether, under the step transaction doctrine, the acquisition of T stock and subsequent merger or liquidation of T in P qualifies as a reorganization under section 368(a). *Id.*
- c) However, if taxpayers do not make a section 338(h)(10) election, Rev. Rul. 2001-46 will continue to apply so as to recharacterize the transaction as a reorganization under section 368(a). *See* Treas. Reg. § 1.338(h)(10)-1(e) ex. 11.
- d) These regulations are effective for stock acquisitions occurring on or after July 5, 2006.

21. Example 21 -- Rev. Rul. 2001-46: Situation 2

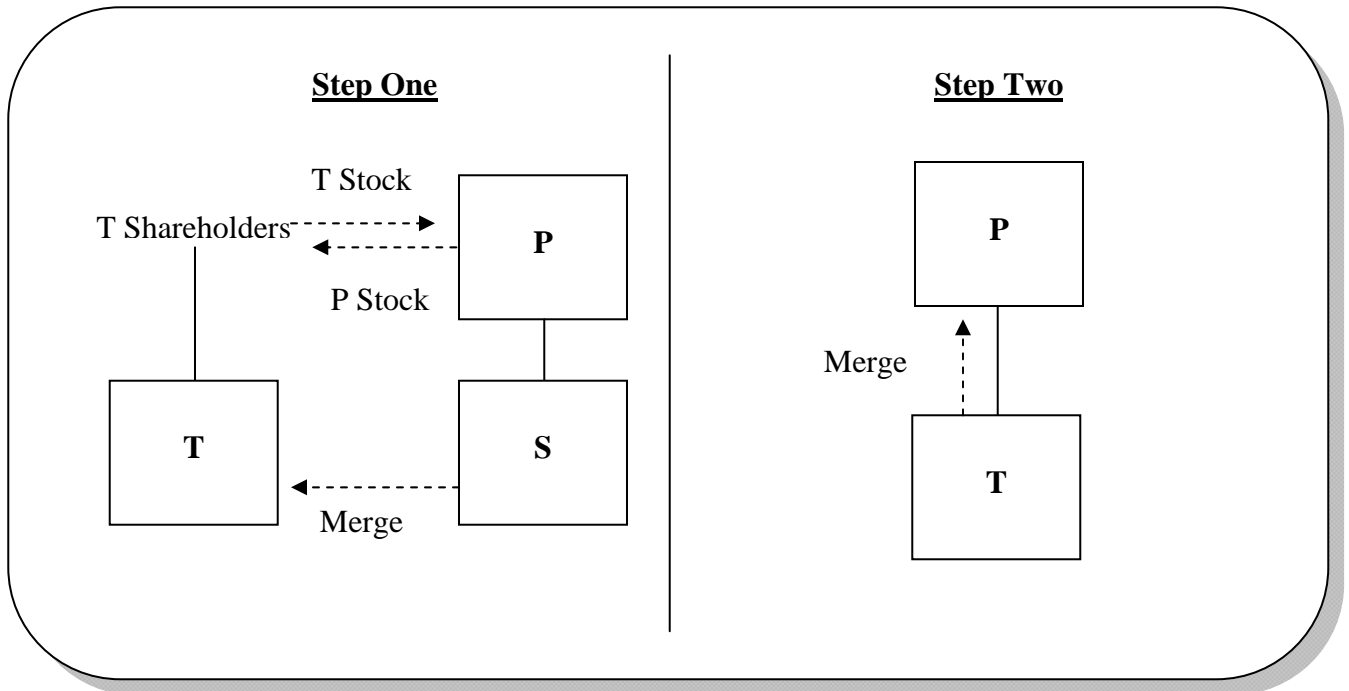

a. Facts: Same facts as Example 20, except that the T shareholders receive solely P stock in exchange for their T stock, so that the merger of S into T, if viewed independently of the upstream merger of T into P, would qualify as a reorganization under section 368(a)(1)(A) by reason of section 368(a)(2)(E).

b. Issues:

- (1) Under these facts, one could argue that the combined steps 1 and 2 should be treated as an “A” reorganization.
- (2) Rev. Rul. 2001-46 rules that step transaction principles apply to treat this transaction as a merger of T directly into P under section 368(a)(1)(A).
- (3) Note that taxpayers cannot change this result under the new section 338 regulations described in Example 20, above, because, standing alone, P’s acquisition of T does not constitute a qualified stock purchase.
- (4) In addition this treatment was accorded in PLR 9109055 (Dec. 5, 1990) and PLR 8947057 (Aug. 31, 1989) (stock for stock exchange followed by an upstream merger is an “A” reorganization “provided the merger of [target] with and into [acquiror] qualifies as a statutory merger under applicable state law”). *See also* PLR 200213019 (Dec. 21,

2001) (assuming step transaction doctrine applies, reverse subsidiary merger followed by upstream merger is an “A” reorganization), PLR 200203058 (Oct. 22, 2001) (same), PLR 200145039 (Aug. 13, 2001) (same), PLR 200140068 (July 10, 2001) (same), PLR 200140011 (June 7, 2001) (same), PLR 200121010 (Feb. 7, 2001) (same) PLR 200109037 (Dec. 4, 2000) (same), 200021032 (Feb. 23, 2000) (same), PLR 200021031 (Feb. 23, 2000) (same), PLR 199945030 (Aug. 13, 1999) (same), PLR 199924038 (Mar. 22, 1999) (same), PLR 9840004 (July 9, 1998) (same), PLR 9836032 (June 10, 1998) (same), and PLR 9539018 (June 30, 1995) (same). In an anomalous ruling, the Service reach a different result in PLR 8925087 (Mar. 30, 1989), where a stock for stock exchange after which the acquiror “will liquidate Target by means of a short form merger” was held to be a “C” reorganization.

c. Variation

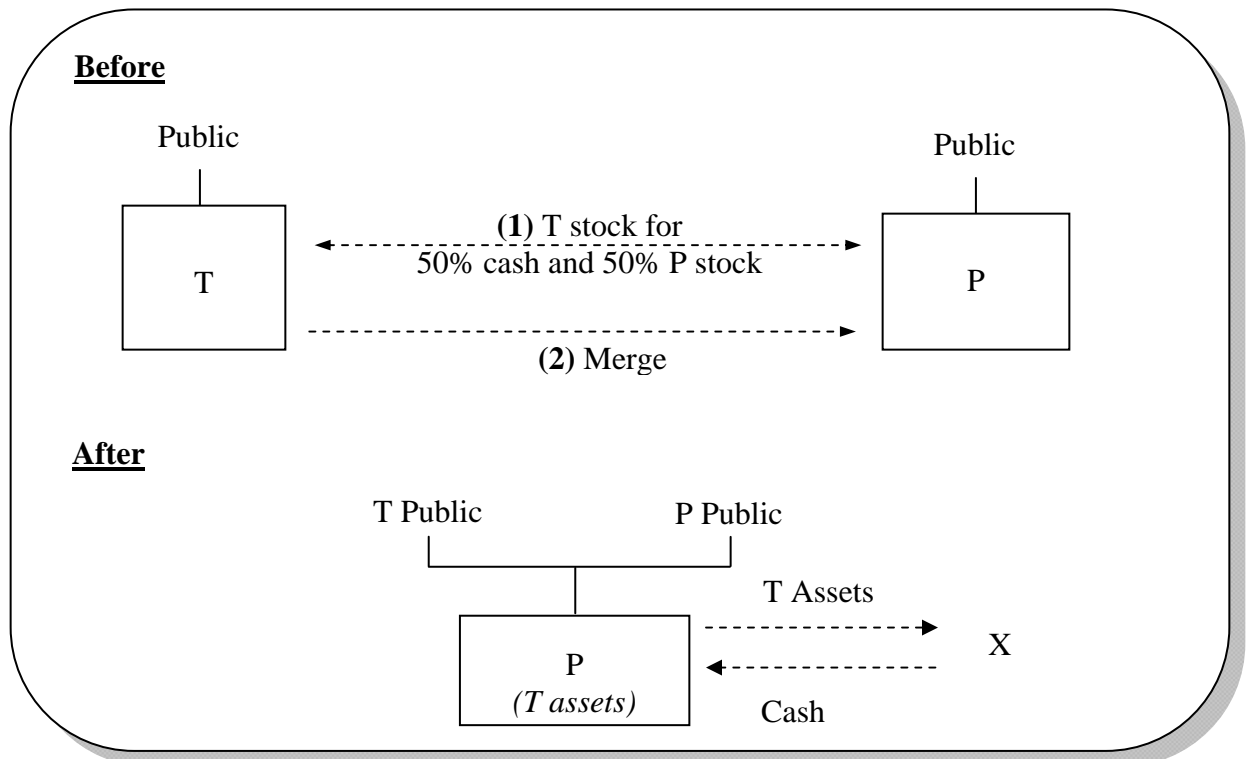

- (1) Facts: The shareholders of T exchange all of their T stock for consideration consisting of 50% P voting stock and 50% cash. Immediately following the exchange, and as part of the overall plan, P causes T to merge upstream into P. Immediately after the merger, P sells T’s assets to X, an unrelated third party.

(2) Issues:

- a) Does the step transaction doctrine apply to this transaction?
- b) What is the result of this transaction for Federal income tax purposes?

d. Additional Variation

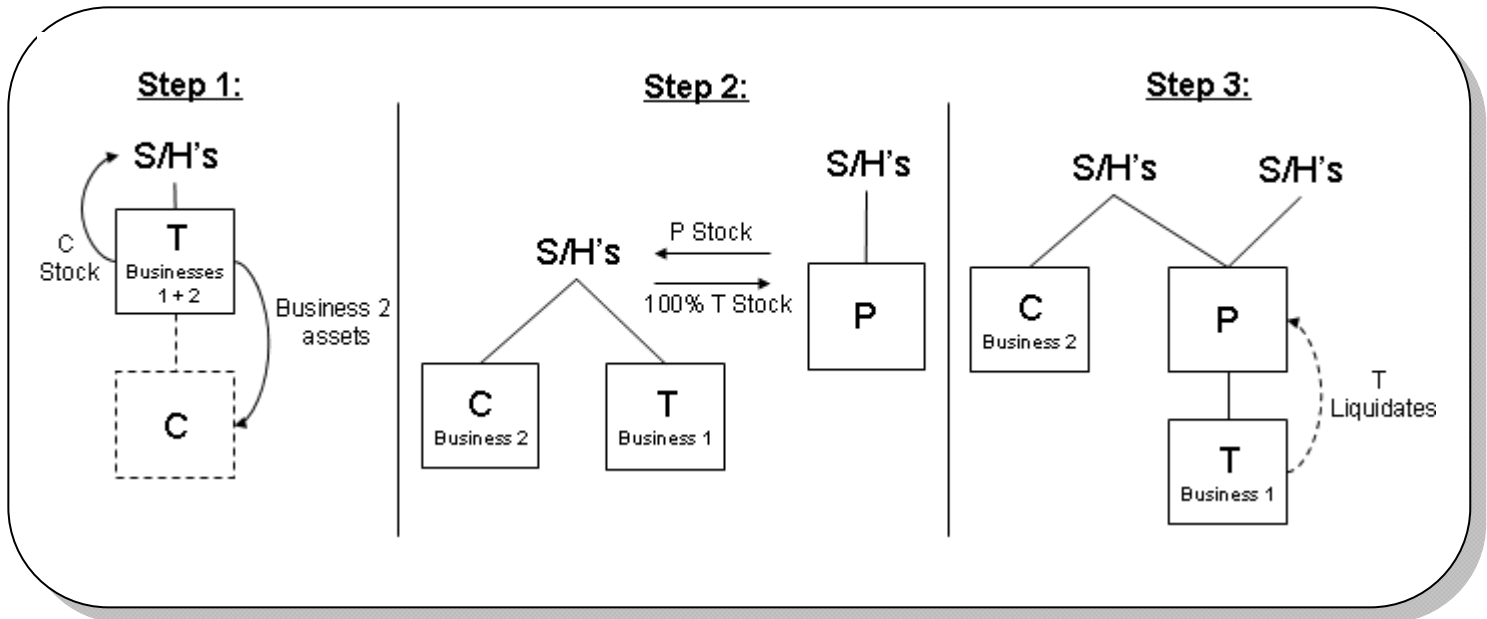

- (1) Facts: T operates Business 1 and Business 2. T contributes all of its Business 2 assets to C, a newly formed, wholly owned subsidiary. T distributes the stock of C to T shareholders in a spin-off. P acquires T from the T shareholders in exchange for P stock. Immediately thereafter, T is liquidated into P.

(2) Issues:

- a) In form, the above steps constitute a section 355 transaction, a B reorganization, and a section 332 liquidation.
- b) However, step transaction principles apply to treat P's acquisition of T as if (i) P purchased a portion of T's assets and (ii) T liquidated into P. *See Rev. Rul. 67-274; Elkhorn Coal.* Under Rev. Rul. 67-274, P's acquisition of T is not a valid B reorganization. Because T liquidates in P, Rev. Rul.

67-274 combines the steps and treats the transaction as an acquisition by P of T's assets in a C reorganization. In this transaction, the acquisition does not qualify as a C reorganization because *Elkhorn Coal* steps together the spin-off and the acquisition such that P can't be said to acquire substantially all of T's assets. Therefore the transaction will be a taxable acquisition and not a tax-free reorganization.

- c) Can P's acquisition of T be treated as a qualified stock purchase followed by a section 332 liquidation? *See* Rev. Rul. 2001-46; Treas. Reg. § 1.338-3(c)(1)(i),(2); Treas. Reg. § 1.338(h)(10)-1(c)(2), (e).

22. Example 22 -- Rev. Rul. 2008-25

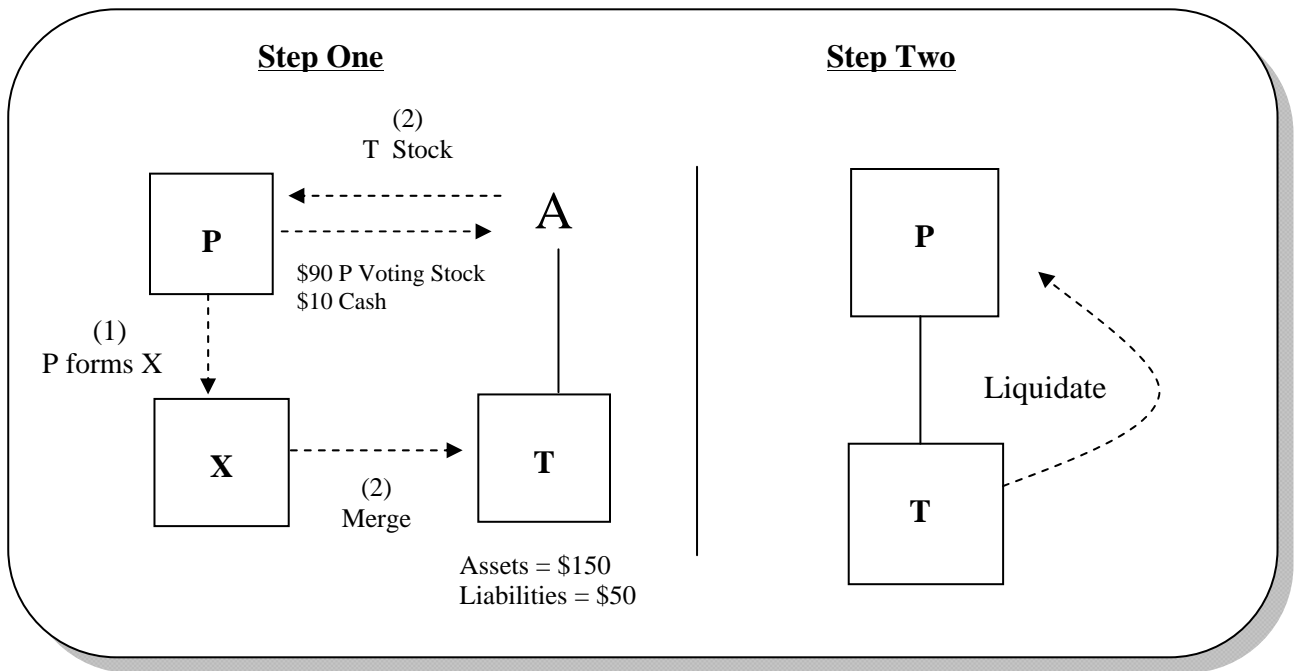

a. Facts: A, an individual, owns all the stock of T which holds assets worth \$150 and liabilities of \$50. P corporation is unrelated to A and T and has assets of \$410. P forms a wholly owned subsidiary X for the sole purpose of acquiring all the stock of T through a reverse subsidiary merger. In the merger, P acquires all of the stock of T, and A exchanges the T stock for \$10 cash and \$90 of voting stock of P. Following the merger, and as a part of an integrated plan that included the merger, T completely liquidates into P. In the liquidation, T transfers all of its assets into P and P assumes all of T's liabilities.

b. Issues:

- (1) If treated as separate transactions the merger would be a reorganization under section 368(a)(1)(A) by reason of section 368(a)(2)(E) and the liquidation would be tax free under section 332.
- (2) However, in Rev. Rul. 2008-25, 2008-21 I.R.B. 986, the Service determined that the merger and the liquidation can not be considered independently in determining whether the requirements for a section 368 merger apply. Because T is completely liquidated, the safe harbor exception from

the application of the step transaction doctrine does not apply. Treas. Reg. § 1.368-2(k).

- (3) When the merger and liquidation are integrated, the transaction fails to qualify as a reorganization under section 368. The transaction is not a reorganization under section 368(a)(1)(A) by reason of section 368(a)(2)(E) because T does not hold substantially all of its property and the properties of the merged corporation at the end of the transaction. It also fails as a B, C, or D reorganization. Forty percent of the consideration for T is not P voting stock so the transaction is not a B or C reorganization. Finally, because neither A nor T was in control of P immediately after the transfer it does not qualify as a D reorganization.
- (4) If the Service fully followed the approach in Rev. Rul. 67-274 and Rev. Rul. 2001-46 the acquisition and liquidation would be treated as a direct acquisition of T's assets by P in exchange for cash and stock and the assumption of T's liabilities. However, this treatment would violate the policy of section 338 by treating the acquisition of T's stock as a taxable purchase of T's assets with the resulting cost basis without a section 338 election.
- (5) Therefore, the ruling steps together the first part of the transaction and treats P's acquisition of T's stock not as section 368 reorganization but rather as a qualified stock purchase by P of the stock of T under section 338(d)(3). Then following the approach of Rev. Rul. 90-95, the liquidation is determined to be a complete liquidation of a controlled subsidiary under section 332.

23. Example 23 -- Rev. Rul. 2004-83

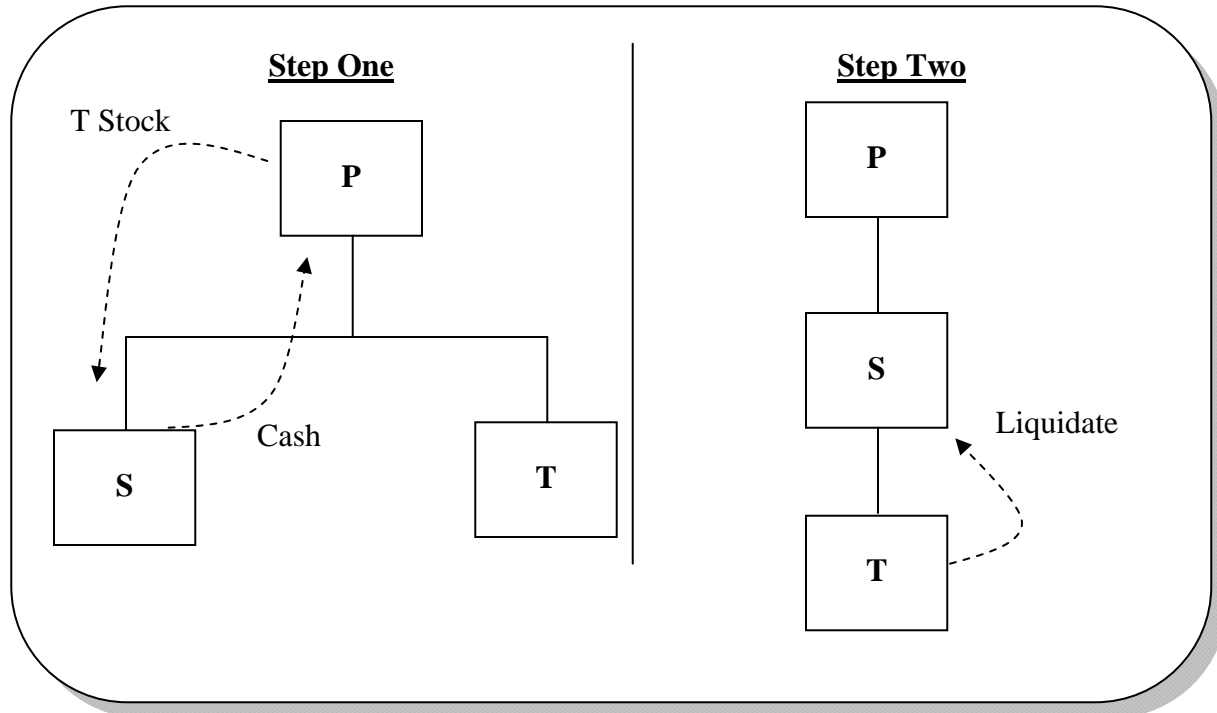

- a. Facts: Corporation P owns all the stock of Corporation S and Corporation T. P, S, and T are members of a consolidated group. As part of an integrated plan, S purchases all the stock of T from P for cash and T completely liquidates into S.
- b. Issues:
- (1) Will the rationale of Rev. Rul. 67-274 apply to step the two mergers together, or will the rationale of Rev. Rul. 90-95 apply and treat the mergers as independent transactions? If T had transferred its assets directly to S and T had completely liquidated into P, the stock sale and liquidation would have qualified as a reorganization under section 368(a)(1)(D).
 - (2) Rev. Rul. 2004-83 rules that step transaction principles apply to treat this transaction as a merger of T into S under section 368(a)(1)(D).
 - (3) In addition, in the Service's view, the result would be no different if P, S, and T were not members of a consolidated group. In the Service's view, no policy exists that would require section 304 to apply where section 368(a)(1)(D) would otherwise apply. See Rev. Rul. 2004-83, *Situation 2*.

24. Example 24 -- Section 304 or “D” Reorganization

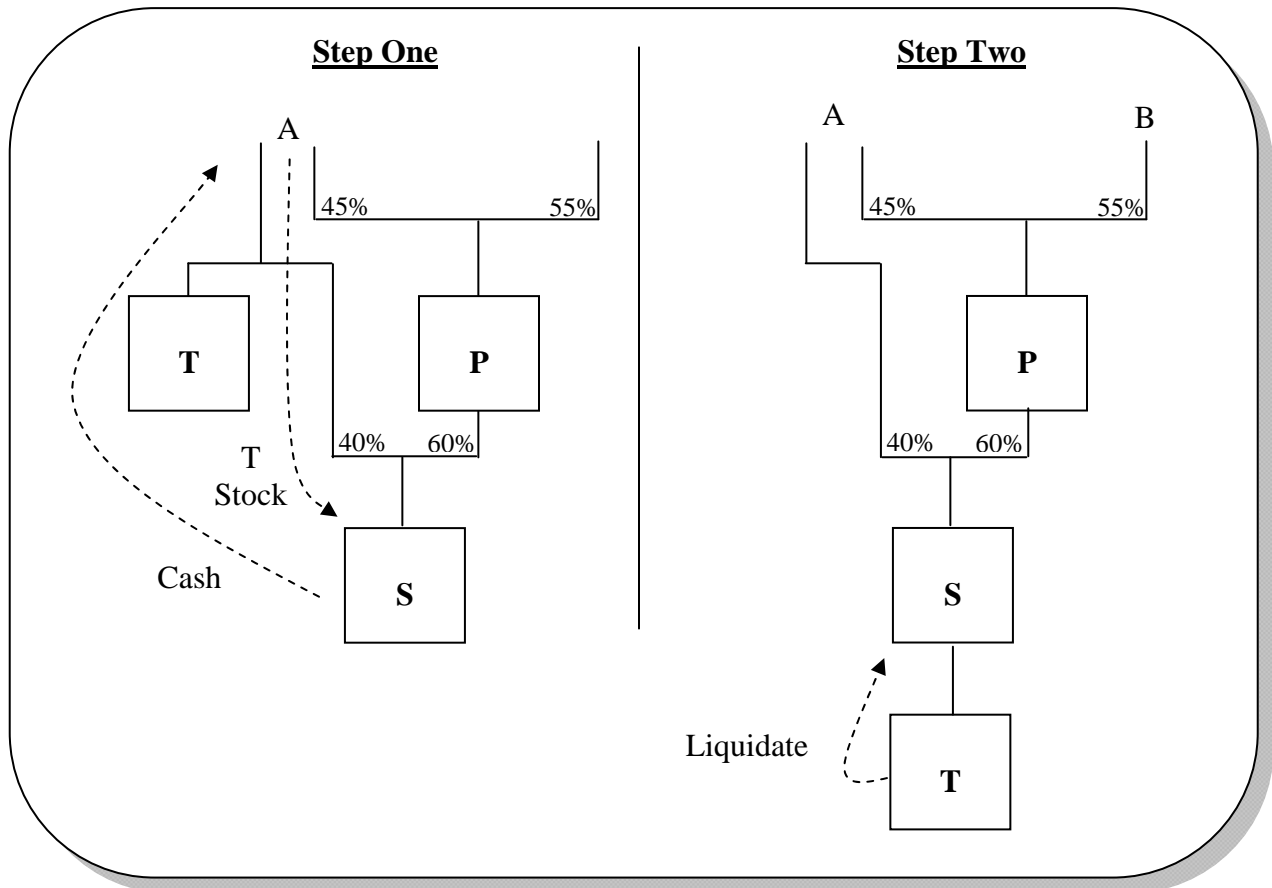

a. Facts: A owns 100 percent of T, 45 percent of P, and 40 percent of S. P owns the remaining 60 percent of S, and B owns the remaining 55 percent of P. A sells the stock of T to S for cash. Following the sale, T is liquidated into S.

b. Issues:

- (1) The receipt of cash by A must be tested to determine whether it gives rise to ordinary income or capital gain. However, the parameters of the test may vary, depending on whether the form of the transaction is respected.
- (2) If the form of the transaction is respected, it must be tested under section 304 to see if A is “in control” of both T and S.
 - a) For purposes of section 304, “control” is defined as 50 percent stock ownership by vote or by value. Constructive ownership is taken into account by looking through all corporations in which a shareholder has a 5 percent or greater interest.

- b) A owns 40 percent of S directly plus 27 percent (60% x 45%) indirectly through P, for a total of 67 percent ownership in S.
 - c) As section 304 applies to the transaction, the cash is treated as a distribution in redemption of stock that must be tested for dividend equivalence.
 - d) A's percentage ownership in T is reduced from 100 percent before the transaction to 67 percent after the transaction. *See* section 304(b). Query whether this results in dividend treatment under section 302.
- (3) If the acquisition of T by S, and the subsequent liquidation of T are stepped together, the transaction would qualify as a “D” reorganization.
- a) For purposes of a non-divisive “D” the section 304 rules apply for determining “control.” Section 368(a)(2)(H).
 - b) However, for purposes of determining dividend equivalence under section 356, the attribution rules of section 318 are not modified so as to take into account constructive ownership through less than 50 percent owned corporations.
 - i) As a result A's percentage ownership would be reduced from 100 percent to 40 percent.
 - ii) This would clearly qualify for exchange treatment under section 302.
- (4) In different cases, similar transactions have been analyzed as either a sale followed by a liquidation or as a “D” reorganization. *See Frederick Steel Co. v. Commissioner*, 42 T.C. 13 (1964) (sale and liquidation), *rev'd and rem'd on other grounds*, 375 F.2d 351 (6th Cir.); Rev. Rul. 77-427, 1977-2 C.B. 100 (same); PLR 9245016 (Aug. 5, 1992) (reorganization); PLR 9111055 (Dec. 19, 1990) (same).

25. Example 25 -- Rev. Rul. 70-140

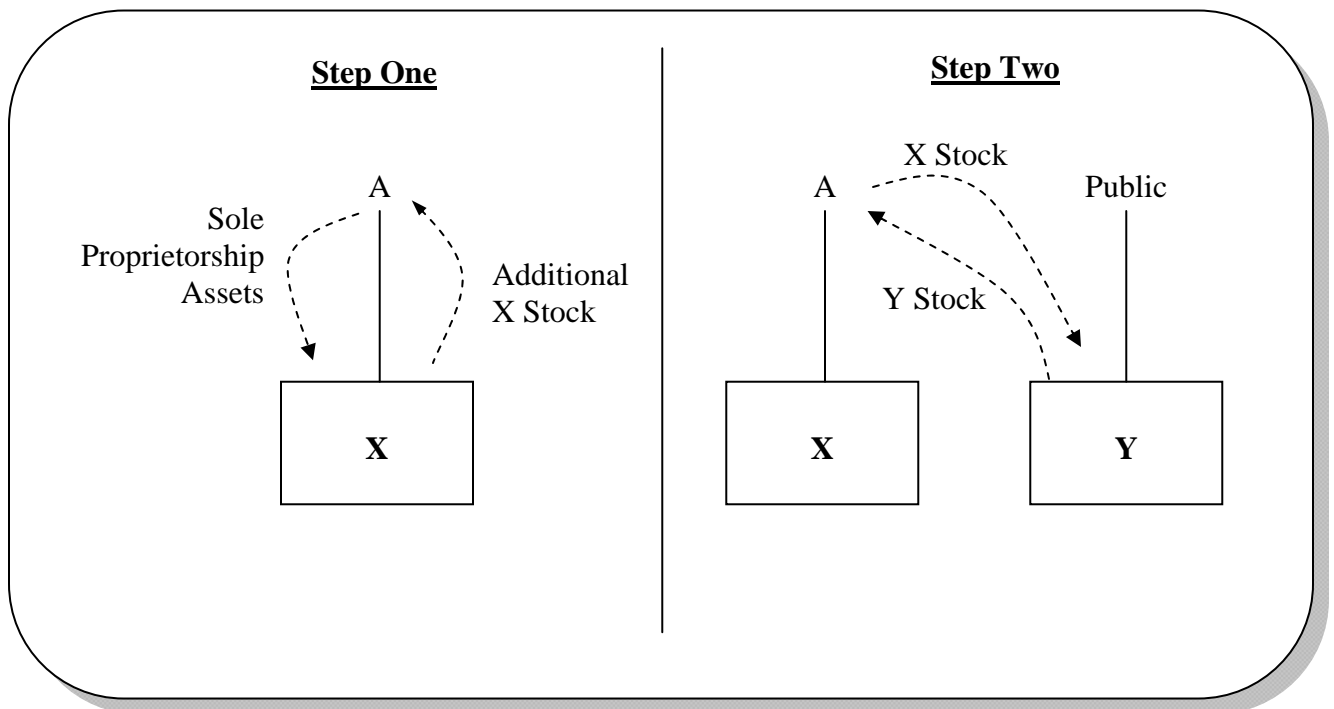

- a. Facts: A owns all of the stock of X and operates a business similar to the business of X through a sole proprietorship. A transfers its sole proprietorship to X in exchange for additional X stock. A then transfers all of the stock of X to Y, an unrelated, widely held corporation in exchange for Y voting stock. Both steps were part of a prearranged plan.

b. Issues:

- (1) Does the transfer of the sole proprietorship to X in exchange for X stock qualify as a section 351 exchange?
- (2) In Rev. Rul. 70-140, 1970-1 C.B. 73, the Service ruled that it did not because, in the Service's view, the sole proprietorship was only transferred to X to allow A to transfer those assets to Y tax-free. Rev. Rul. 70-140 provides that the transaction should be recharacterized as a transfer by A of the sole proprietorship directly to Y in a transfer to which section 351 does not apply, followed by a transfer of these assets by Y to X, and a separate transfer of X stock by A to Y for Y voting stock.

26. Example 26 -- Rev. Rul. 2003-51

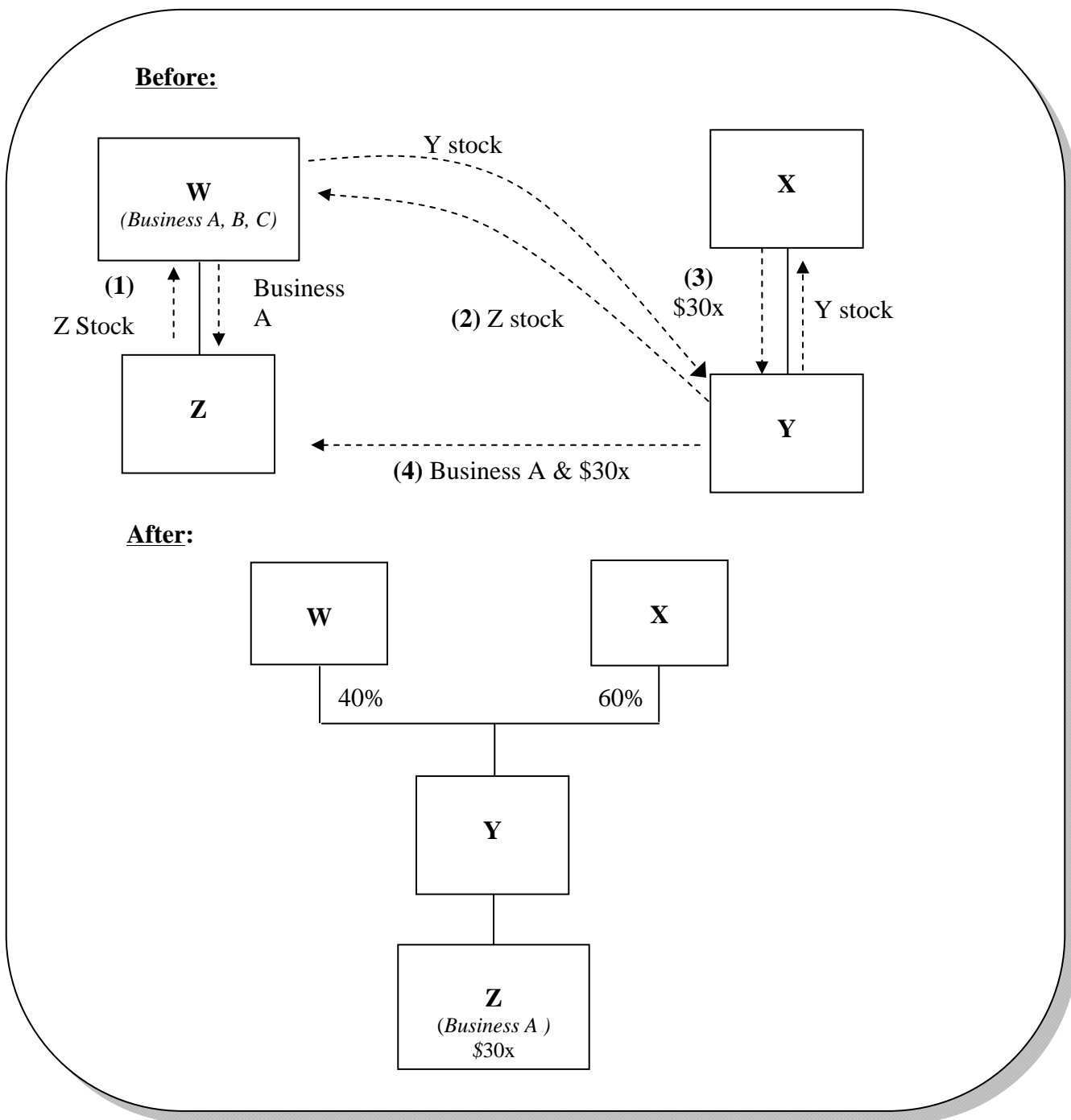

- a. Facts: Corporation W engages in Businesses A, B, and C. X, an unrelated corporation, also engages in Business A through its wholly-owned subsidiary, corporation Y. The corporations desire to combine their businesses in a holding company structure. Under a prearranged plan, the following transfers take place: (1) W forms Z and contributes its Business A to Z for Z stock (the “First Transfer”); (2) W contributes its Z stock to Y in exchange for Y

stock (the “Second Transfer”); (3) simultaneously, X transfers \$30x to Y in exchange for additional Y stock to meet the capital needs of Business A (the “Third Transfer”); and (4) Y transfers the \$30x and its Business A to Z, which is now a wholly-owned subsidiary of Y (the “Fourth Transfer”). After the transfers, W owns 40% of Y stock and X owns 60% of Y stock.

b. Issues:

- (1) In Rev. Rul. 2003-51, 2003-1 C.B. 938, the Service ruled that the First Transfer qualifies as a tax-free exchange under section 351, notwithstanding the subsequent transfers.
- (2) The Service stated that the existence of a prearranged plan between W and X made it necessary to determine whether the Second and Third Transfers caused the First Transfer to fail the control requirement of section 351.
- (3) Unlike Rev. Rul. 67-274, Rev. Rul. 2001-26, and Rev. Rul. 2001-46, the Service did not recharacterize the steps of the transaction, but instead adhered to the form of the transfers and ruled that the Second and Third Transfers did not cause the First Transfer to fail the control requirement of section 351.
- (4) The Service distinguished Rev. Rul. 70-140, 1970-1 C.B. 73, on the basis that the transfer of Business A to Z was not necessary for the parties to have structured the transaction in a tax-free manner.
- (5) Assume the following facts. W, a corporation engages in Businesses A, B, and C. X, an unrelated corporation, also engages in Business A through its wholly-owned subsidiary, corporation Y. Individual A has Business A assets. Under a prearranged plan, the following steps take place: (1) W and A form Z. W contributes its Business A to Z for 60% of the Z stock and A contributes its Business A assets and cash to Z for 40% of the Z stock; (2) W contributes its Z stock (60%) to Y in exchange for Y stock; (3) simultaneously, X transfers cash to Y in exchange for additional Y stock to meet the capital needs of Business A; and (4) Y transfers the cash and its Business A to Z for additional Z stock. After the transfers, W owns 40% of Y stock and X owns 60% of Y stock. Y owns 75% of Z stock and A owns 25% of Z stock.

- a) Under the reasoning of Rev. Rul. 2003-51, W's transfer of Business A and A's transfer of Business A assets and cash to Z for Z stock (Transfer 1) should qualify as a tax-free exchange under section 351, notwithstanding the subsequent transfers.
 - b) Query whether under Rev. Rul. 2003-51, Transfers 2 and 3 (combined) and Transfer 4 would be treated as separate exchanges? If so, Transfers 2 and 3 would be a tax-free exchange under section 351, but Transfer 4 would not be a tax-free exchange under section 351 because Y does not satisfy the control test. Is this inconsistent with Rev. Rul. 70-140?
- (6) Rev. Rul. 2003-51 appears limited to section 351 transactions. Nonetheless, it is unclear why the Service did not step the transfers together as it did with the two mergers in Rev. Rul. 2001-46. *But see Esmark, Inc. & Affiliated Cos. v. Commissioner*, 90 T.C. 171 (1988).

27. Example 27 -- Assumption of Liabilities in Triangular "C" Reorganizations

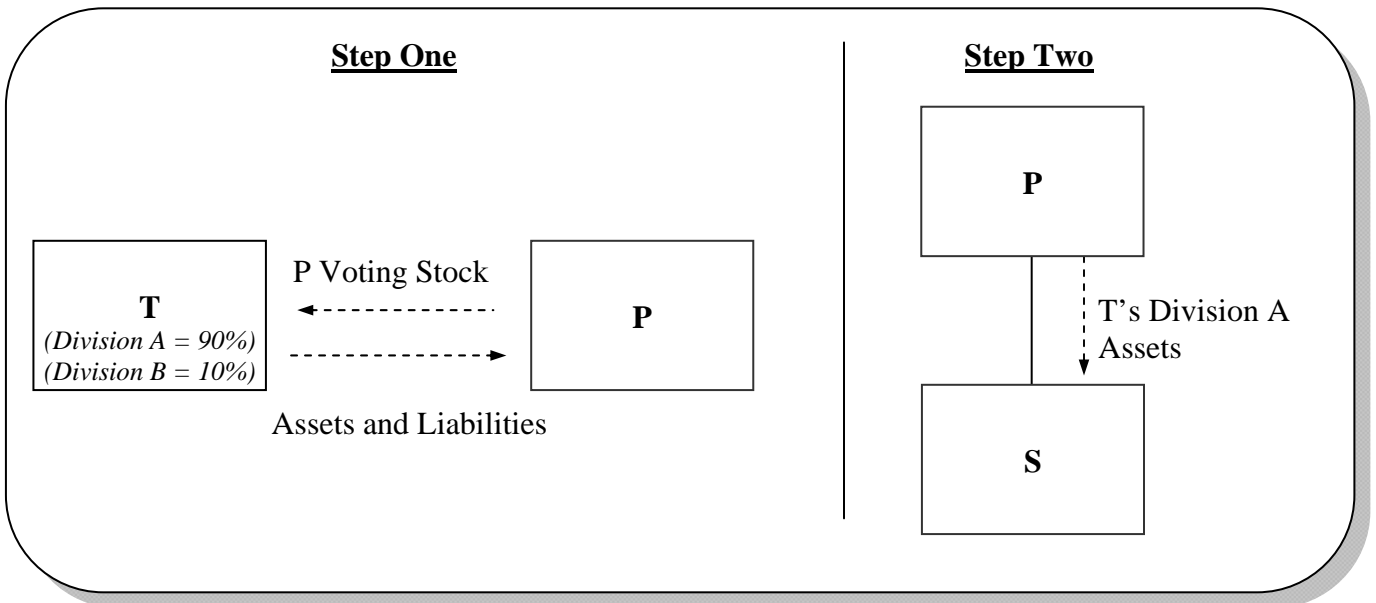

- a. Facts: T corporation operates two divisions, Division A (which represents 90% of the value of T's assets) and Division B (which represents 10% of the value of T's assets). Pursuant to a plan to acquire T, (i) P forms S; (ii) T transfers all of its assets to P in exchange solely for voting common stock of P; (iii) P assumes T's liabilities; (iv) T liquidates, distributing P stock to its shareholders;

and (v) pursuant to the plan of reorganization, P contributes the Division A assets to S. Assume that, with the possible exception of the transfer of assets to S, the transaction qualifies as a reorganization under section 368(a)(1)(C).

b. Issue: Whether the subsequent contribution of Division A assets to S affects the treatment of the transaction as a “C” reorganization.

(1) The dropdown should not prevent the transaction from qualifying if it otherwise meets the requirements of section 368(a)(1)(C). *See* section 368(a)(2)(C) (stating that a transaction otherwise qualifying is not disqualified if assets are transferred to a corporation controlled by the “acquiring” corporation). *See also* Treas. Reg. § 1.368-2(k) (stating that a transaction otherwise qualifying as an A, B, C, or G reorganization will not be disqualified by reason of the fact that a part or all of the acquired assets or stock are transferred or successively transferred to one or more corporations controlled in each transfer by the transferor corporation). Thus, P is the “acquiring corporation.” *Cf.* Rev. Rul. 70-224, 1970-1 C.B. 79.

(2) Note, however, that for purposes of determining which corporation succeeds to T's attributes, the “acquiring corporation” may be different.

a) Under section 381, there can be only one “acquiring corporation,” which generally will be the corporation that ultimately acquires “all” of the assets pursuant to the plan of reorganization. If no single corporation acquires “all” of the assets, the corporation directly acquiring the assets will be the “acquiring corporation.” *See* Treas. Reg. § 1.381(a)-1(b)(2). *But see* Treas. Reg. § 1.381-1(b)(3)(ii).

b) In this case, no single corporation will have acquired “all” of the assets, although S will have acquired “substantially all” of the assets. Therefore, P should be the “acquiring” corporation for section 381 purposes and inherit T's attributes. It is possible that the form would be disregarded if all but a “de minimis” portion of the assets were transferred to S.

(3) Now assume that S assumes the liabilities associated with the Division A assets. To qualify as a “C” reorganization the assets must be acquired solely for voting stock of the

“acquiring corporation” (or stock of a corporation in control of the “acquiring corporation”).

- a) The assumption of liabilities by the “acquiring corporation” is not treated as boot. *See* section 368(a)(1)(C). However, in this case, P is the “acquiring corporation.” *Cf.* Rev. Rul. 70-224, 1970-1 C.B. 79.
- b) The Service has ruled that, where a corporation other than the “acquiring corporation” assumes the liabilities, this may disqualify the transaction. *See* Rev. Rul. 70-107, 1970-1 C.B. 78. *But see* G.C.M. 39102 (Dec. 21, 1983) (questioning Rev. Rul. 70-107 and suggesting that any party to the reorganization should be able to assume part or all of the liabilities.) Thus, at least as a technical matter, this raises a concern that S's assumption of liabilities must be viewed as boot.
- c) However, it seems anomalous to disqualify the transaction on these grounds. Section 351 expressly contemplates the transfer of assets subject to liabilities. *See* sections 351(h)(1) and 357(a). Further-more, as discussed below, the Service appears to permit subsidiaries in so-called “cause to be directed” transactions to assume liabilities, even though it treats such transactions as if the assets and liabilities were initially acquired by the parent corporation.
 - i) The continuity of business enterprise (“COBE”) regulations permit transfers of target assets to members of a qualified group; the regulations do not, however, address the issues presented by assumption of liabilities by a party other than the acquiring company in a “C” reorganization.
 - ii) Note that, if the initial acquisition had been structured as an “(a)(2)(D)” merger of T into S rather than a “C” reorganization, the assumption of liabilities by P, a corporation other than the “acquiring corporation,” would have been permitted. *See* Reg. § 1.368-2(b)(2) (parent may assume liabilities of target in an “(a)(2)(D)” merger).

iii) However, as there is no requirement that an (a)(2)(D) merger be “solely” for voting stock, this would presumably only present an issue if the liabilities assumed by P were sufficiently large to threaten continuity.

(4) Now assume that the Division A assets are transferred by S to S1, a wholly-owned subsidiary of S.

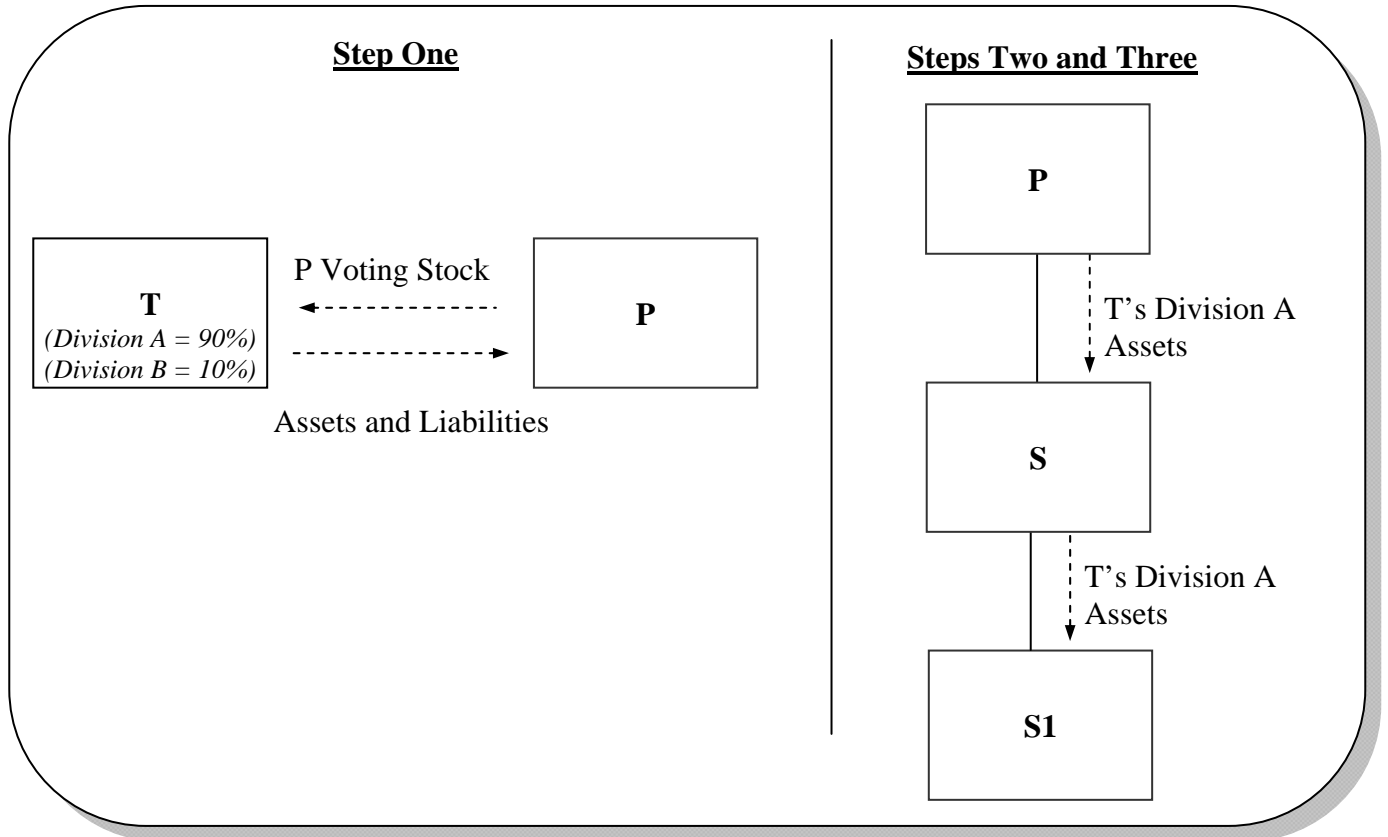

a) A transfer of assets to a second-tier subsidiary does not prevent a transaction that otherwise qualifies from meeting the requirements of a “C” reorganization. See Reg. § 1.368-2(k); Reg. § 1.368-1(d). See also Rev. Rul. 64-73, 1964-1 C.B. 142; G.C.M. 30887 (Oct. 11, 1963). Indeed, even asset dropdowns to third-tier subsidiaries are permissible. Treas. Reg. §§ 1.368-2(k), 1.368-1(d). See PLRs 9313024 (Dec. 31 1992) and 9151036 (Sept. 25, 1991). It is also permissible to transfer the assets to multiple controlled subsidiaries. See Treas. Reg. § 1.368-1(d)(5), Example 6; Rev. Rul. 68-261, 1968-1 C.B. 147. These authorities reflect a fairly liberal approach by the Service to post-reorganization dropdowns of acquired assets.

- b) Under the COBE regulations, transfers of assets to any member of the “qualified group” will be permitted. *See* Treas. Reg. § 1.368-1(d).

28. Example 28 -- “Cause To Be Directed” Transfer

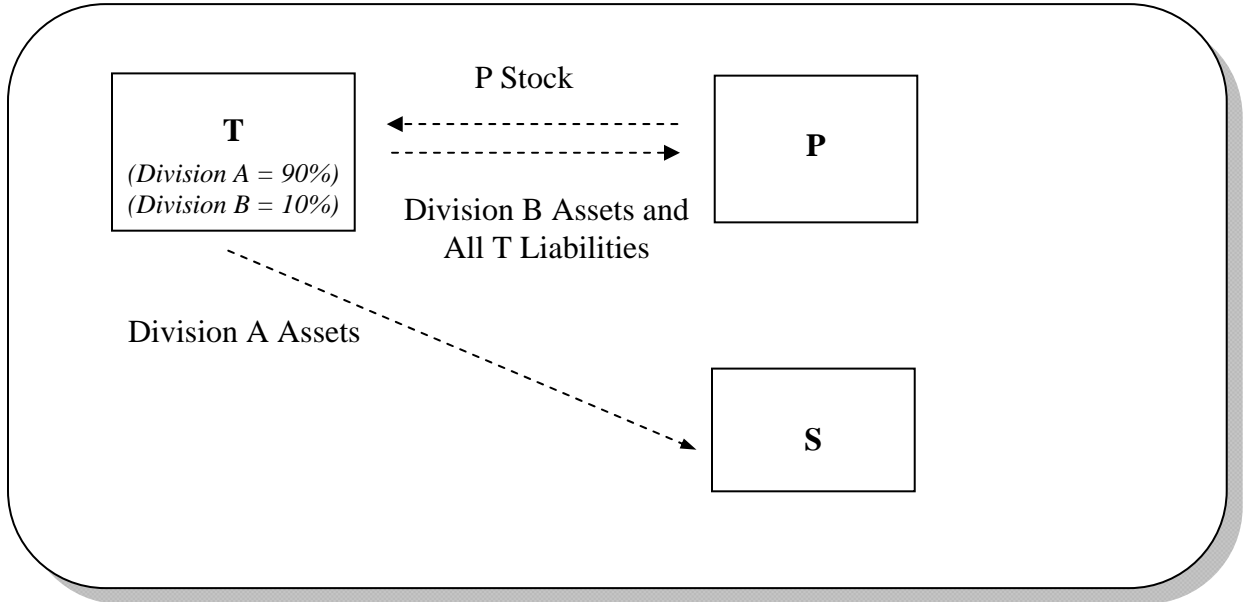

- a. Facts: T corporation operates two divisions, Division A (which represents 90% of the value of T's assets) and Division B (which represents 10% of the value of T's assets). Pursuant to a plan to acquire T, (i) P forms S; (ii) T transfers the Division A assets directly to S and the remaining assets to P in exchange solely for voting common stock of P; (iii) P assumes T's liabilities; and (iv) T liquidates distributing P stock to its shareholders.
- b. Issues: What is the effect of the direct transfer of Division A assets on the initial acquisition?
- (1) The Service will analyze the transaction as if P acquired substantially all the T assets for P stock and immediately thereafter, transferred the Division A assets to S. *See* Rev. Rul. 64-73, 1964-1 C.B. 142. This analysis is based on the theory that P had “dominion and control” of the assets at all times. *See* Rev. Rul. 70-224, 1970-1 C.B. 79. Therefore, under section 368(a)(2)(C), the transaction will not cease to qualify as a “C” reorganization as a result of the deemed transfer of assets to S.
 - (2) Now assume that S assumes some or all of the T liabilities in addition to receiving the Division A assets. One might

question whether P is in substance the “acquiring corporation”. Cf. G.C.M. 37905 (Mar. 29, 1979).

- a) The Service will treat the transaction as an acquisition of assets and liabilities by P followed by a contribution of such assets and some or all of the liabilities to S. See PLRs 9523012 (Mar. 10, 1995), 7942016 (July 17, 1979), 7903110 (Oct. 23, 1978). Thus, notwithstanding G.C.M. 37905 (Mar. 29, 1979) (which determines the “acquiring corporation” in an asset pushup based on the substance of the transaction), in this context the transaction apparently will not be treated as an acquisition by S of the assets and liabilities of T.
 - b) Although private letter rulings approve cause to be directed transactions (as valid “C” reorganizations) where liabilities are assumed by a corporation other than the acquiror, this transaction could be disqualified by Rev. Rul. 70-107, as discussed in Example 27 above. But see G.C.M. 39102 (Dec. 21, 1983) (questioning Rev. Rul. 70-107).
 - c) We understand that the Service may be reconsidering its position regarding cause to be directed transactions. If S assumes the liabilities of T, the Service may apply Rev. Rul. 70-107 and treat the liabilities as boot.
- (3) What if, instead of directing that T's assets and liabilities be transferred to S, T transfers the Division B assets to P and then (as directed by P) merges into S?

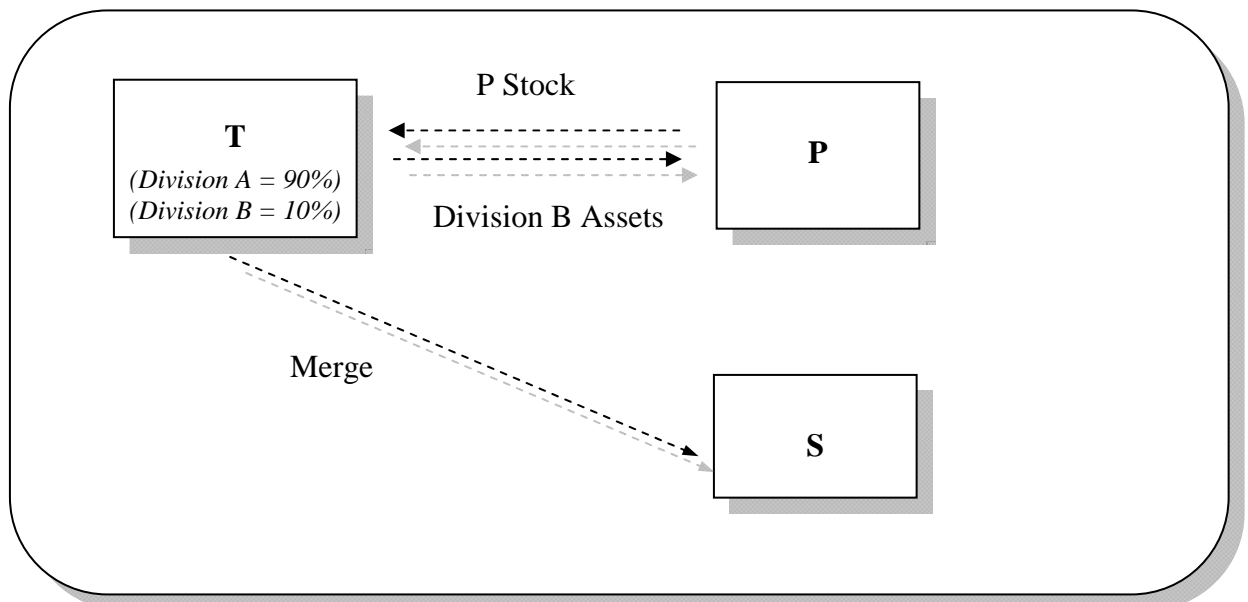

- a) The end result of the transaction appears identical to that of the previous transaction. Indeed, the Service has indicated that, on similar facts, it will treat the transaction as an acquisition of T's assets and liabilities by P followed by a dropdown of those assets and liabilities to S. *See, e.g.*, PLRs 9536032 (June 15, 1995), 9526024 (Apr. 4, 1995), 9409033 (Dec. 7, 1993), 9151036 (Sept. 25, 1991).
 - b) Again, the Service appears to disregard the fact that a corporation other than the “acquiring corporation” has assumed liabilities.
 - c) As noted above, the Service may be reconsidering this position.
- c. The Service is currently considering whether the “cause to be directed” doctrine has continuing vitality in light of the new COBE regulations and Treas. Reg. § 1.368-2(k).

29. Example 29 -- Sale of All of QSub Stock: Rev. Rul. 70-140

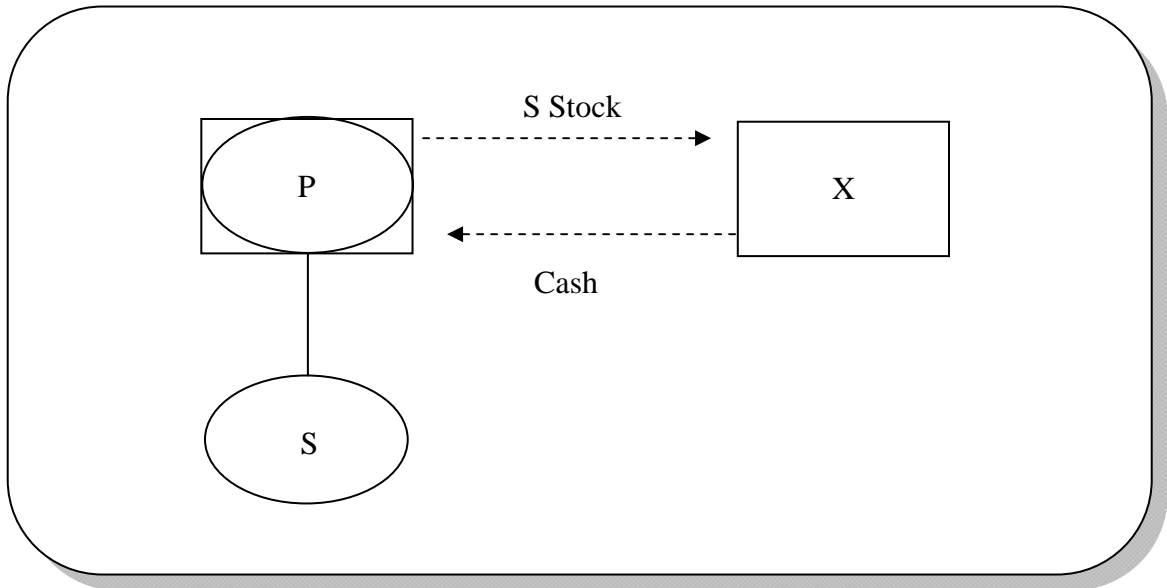

- a. Facts: Corporation P, an S corporation, owns all of the outstanding stock of S, a corporation for which a QSub (qualified subchapter S subsidiary) election has been made. The fair market value of S' assets is \$100, and their adjusted basis is \$50. P sells all of its S stock to X corporation, an unrelated party, for \$100 cash.
- b. Tax Consequences.
- (1) QSub Regulations: Under section 1361(b)(3) and the QSub regulations, T.D. 8869, 2000-1 C.B. 498, a QSub is not treated as a separate corporation, and all assets and liabilities of the QSub are treated as assets and liabilities of its parent corporation. Treas. Reg. § 1.1361-4(a)(1). Upon the sale by P of its S stock, S ceases to be a QSub, and P is treated as if it transferred the S assets to a newly formed corporation, S, and then sold the S stock to X. Treas. Reg. § 1.1361-5(b). Section 351 is not applicable to the transfer of assets to S, because P is not in control of S immediately after the transfer.
 - (2) Rev. Rul. 70-140: Under Rev. Rul. 70-140, 1970-1 C.B. 73, the Service will apparently apply the step transaction doctrine to treat the above transaction as if P sold the assets it was deemed to transfer to S to X. X is then deemed to contribute the assets to S. Thus, P is taxed under section 1001 on the value of the property received (*i.e.*, \$100 cash) minus its adjusted basis in the transferred assets. Therefore, P will have \$50 of gain.

30. Example 30 -- Sale of Portion of QSub Stock

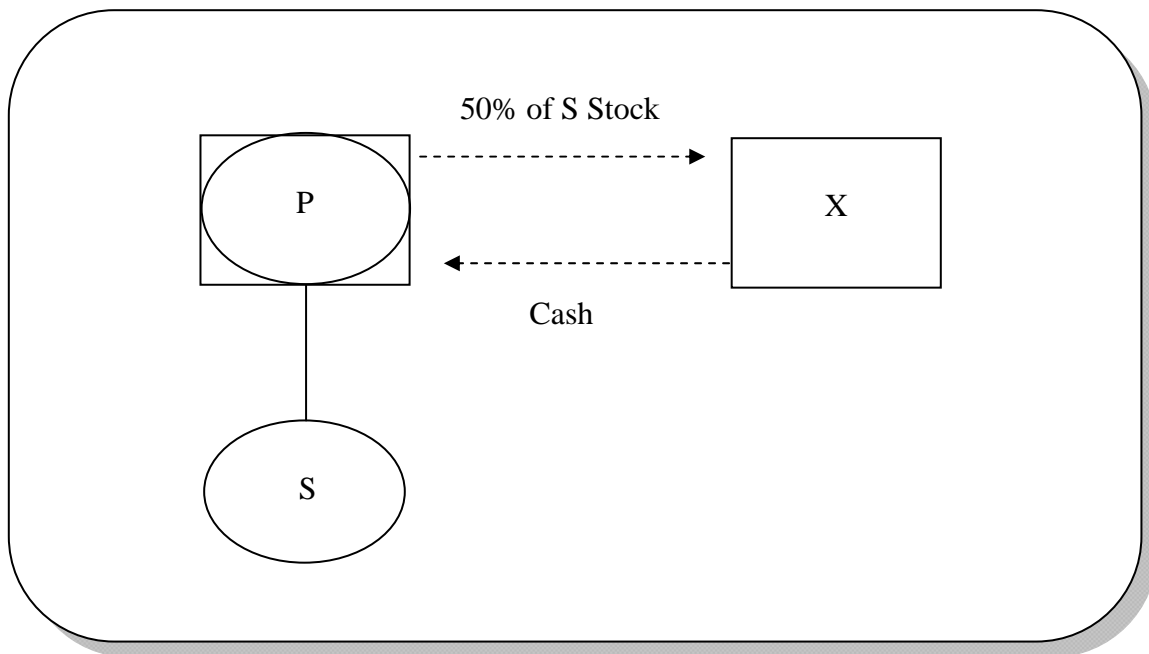

- a. Facts: Same facts as Example 29, except P sells 50% of its S stock to X.
- b. Tax Consequences:
- (1) As noted in the previous example, upon the sale by P of its S stock, S ceases to be a QSub, and P is treated as if it transferred the S assets to a newly formed corporation, S, and then sold the S stock to X. Treas. Reg. § 1.1361-5(b). Section 351 is not applicable to the transfer of assets to S, because P is not in control of S immediately after the transfer. Thus, P must recognize all of the gain attributable to the S assets, even though it only sold one-half of its S stock. See Treas. Reg. § 1.1361-5(b)(3), ex. 1; section 1239. If P had incurred a loss upon the transfer of assets to S, such loss would be subject to the limitations of section 267. *Id.*
 - (2) Rev. Rul. 70-140: The Service apparently will not treat this transaction as a sale of assets directly to X.

31. Example 31 -- Sale of All Membership Interests in LLC

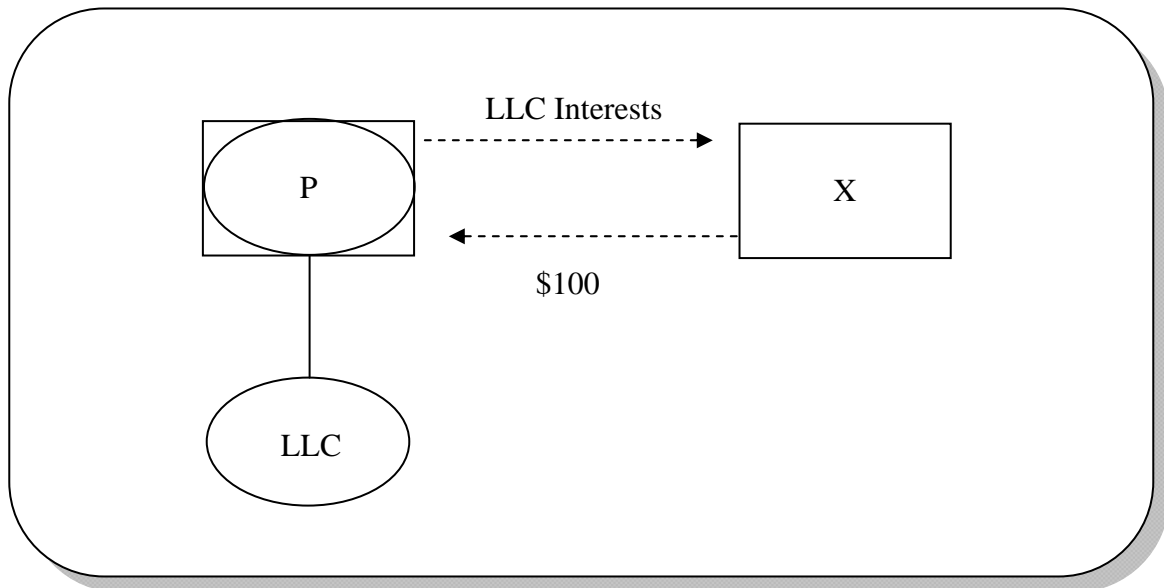

- a. Facts: Corporation P owns all of the outstanding interests in LLC. LLC does not elect to be classified as a association (*i.e.*, it is treated as a disregarded entity). The fair market value of LLC's assets is \$100, and their adjusted basis is \$50. P sells all of the outstanding membership interests in LLC to X corporation, an unrelated party, for \$100.
- b. Tax Consequences:
- (1) LLC is disregarded as an entity separate from P. As a result, P is not treated as owning "interests" in LLC for Federal tax purposes, but rather is treated as owning LLC's assets directly. Thus, the sale of all of the interests in LLC, a disregarded entity, to a single buyer should be treated as a sale of assets by P. Under section 1001, P should recognize gain or loss on the sale, the character of which will depend on the nature of the assets sold.
 - (2) It is not likely that P would be able to change this result by converting LLC into an association taxed as a corporation immediately prior to the sale of the LLC interests to X. The Service will apply step transaction principles to treat P's sale of the LLC interests as the sale of the LLC's assets. *See Rev. Rul. 70-140, 1970-1 C.B. 73.*

c. Treatment of Buyer

- (1) Because LLC will be owned by a single buyer, X, it will remain a disregarded entity in X's hands. *See* Treas. Reg. § 301.7701-3(b)(1)(ii). Accordingly, X should be treated as purchasing the assets of LLC directly from P.
- (2) What if LLC elects to be taxed as an association immediately after the purchase? If a disregarded entity elects to be treated as an association, the owner is treated as contributing all of the assets and liabilities of the disregarded entity to a newly formed association in exchange for stock of the association. Treas. Reg. § 301.7701-3(g)(1)(iv). Thus, X should be treated as contributing the assets of LLC to a newly formed association in a tax-free section 351 exchange.

32. Example 32 -- Sale of Portion of Membership Interests in LLC

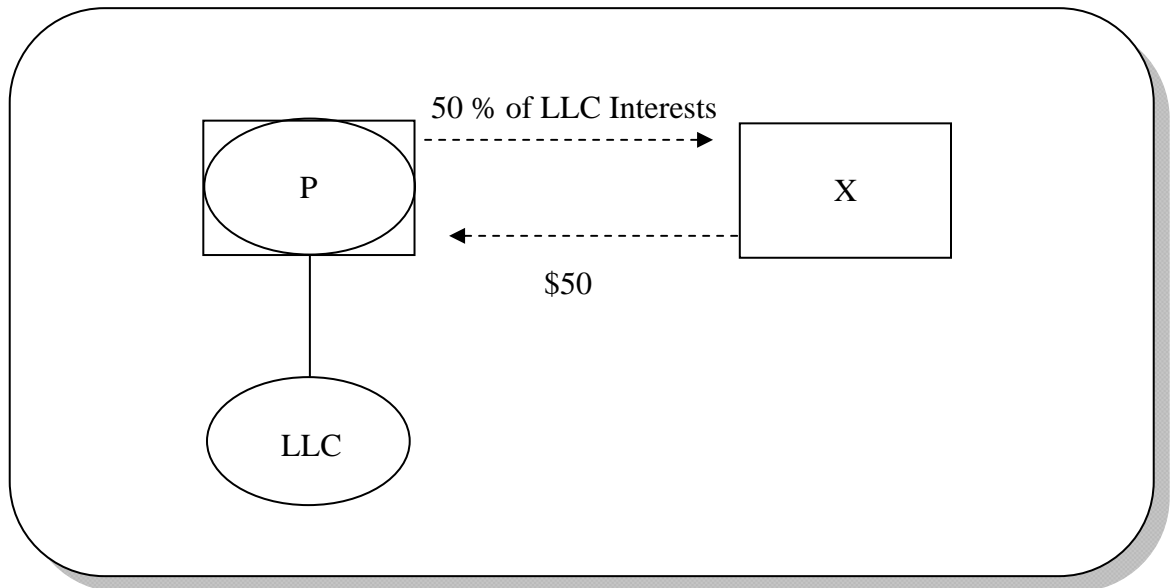

- a. Facts: P owns all of the outstanding interests in LLC, which is treated as a disregarded entity for tax purposes. The fair market value of LLC's assets is \$100, and their adjusted basis is \$50. P sells 50 percent of the outstanding membership interests in LLC to X corporation, an unrelated party, for \$50.
- b. Tax Consequences: LLC is disregarded as an entity separate from P. As a result, P is not treated as owning "interests" in LLC for Federal tax purposes, but rather is treated as owning LLC's assets directly. Thus, the sale of 50 percent of the interests in LLC, a

disregarded entity, to a single buyer should be treated as a sale of 50 percent of the LLC assets by P. P should recognize gain or loss under section 1001, with the character of such gain or loss depending on the character of the assets sold.

- c. Deemed Change In Classification - Immediately after the sale, LLC has two owners and, thus, will be treated as a partnership under the default rules of the check-the-box regulations. Treas. Reg. § 301.7701-3(b)(1)(i). Although the tax consequences of this deemed change in classification are not addressed in the regulations, Rev. Rul. 99-5, 1999-1 C.B. 434, provides some guidance. Following Rev. Rul. 99-5, X would be treated as having purchased assets from P and contributed the assets (with their stepped-up basis) to a newly formed partnership under section 721. The other 50 percent of the assets, which would be deemed contributed by P would not receive a stepped-up basis; instead, LLC would take a carryover basis in those assets. Note that under section 704(c), the built-in gain with respect to the assets contributed by P will be allocated to P.
- d. Section 197 Anti-Churning Rules – Assume that a portion of the assets held by LLC consisted of goodwill, which was not amortizable under pre-section 197 law. Would LLC be permitted to amortize its goodwill after the sale?
- (1) In general, section 197 amortization deductions may not be taken for an asset which was not amortizable under pre-section 197 law, if it is acquired after August 10, 1993, and either (i) the taxpayer or a related person held or used the asset on or after July 25, 1991; (ii) nominal ownership of the intangible changes, but the user of the intangible does not; or (iii) the taxpayer grants the former owner the right to use the asset. See Section 197(f)(1)(A). In addition, under section 197(f)(2), in certain nonrecognition transactions (including section 721 transfers), the transferee is treated as the transferor for purposes of applying section 197.
 - (2) In the example above, P was treated as owning LLC's goodwill directly, prior to the sale of 50 percent of LLC. Because P's deemed contribution of 50 percent of the goodwill was pursuant to section 721, LLC takes a carryover basis in the goodwill (presumably 0), which will not be amortizable by LLC. Because X's half of the goodwill was held by P, who is related to LLC under section 197(f)(9)(C), during the prohibited time period, the anti-churning rules will apply to X's transfer of its 50-percent interest. Therefore, LLC's entire basis in its

goodwill is nonamortizable. *See* Treas. Reg. § 1.197-2(k), Ex. 18.

- (3) What if P sold more than 80 percent of the LLC membership interests to X? In that case, P is not related to the newly formed partnership within the meaning of section 197(f)(9)(C). Thus, the anti-churning rules should not apply. However, under Treas. Reg. § 1.197-2(h)(6)(ii), the time for testing relationships in the case of a series of related transactions or acquisitions is immediately before the “earliest such acquisition” or immediately after the “last such acquisition” of the intangible.
- i) Query whether P is considered related to the newly formed partnership under the final regulation because it was an entity not separate from LLC immediately before the initial acquisition by X.
 - ii) Note that former Prop. Reg. § 1.197-2(h)(6)(ii) stated that the time for testing relationships was any time during the period beginning immediately before the “earliest acquisition” and ending immediately after the “last acquisition” of the intangible. The Preamble to the Final Regulations explains that the change was necessary to avoid deeming parties related that are only momentarily related during the acquisition process. *See* T.D. 8844, 1999-2 C.B. 661.
- (4) There is a special partnership rule for purposes of determining whether the anti-churning rules apply with respect to any increase in basis of partnership property under section 732(d), 734(b), or 743(b). In such cases, the determinations are to be made at the partner level, and each partner is to be treated as having owned or used such partner’s proportionate share of the partnership property. Section 197(f)(9)(E). Thus, if a purchaser acquires an interest in an existing partnership from an unrelated seller, any step up in basis will be treated as a separate section 197 intangible, and the purchaser will be entitled to amortize its share of the step up in basis of the partnership intangibles. Treas. Reg. § 1.197-2(g)(3).
- a) Query whether the anti-churning rules do not apply to a section 743(b) basis increase if the acquiror already owns a greater than 20% interest in the

partnership, and, if the anti-churning rules do not apply, whether such acquiring partner could be allowed to amortize goodwill such partner originally contributed to the partnership.

- b) Recent discussions with Service officials indicate that an acquiring partner that already owns a greater than 20 percent interest in the partnership should be allowed to amortize all goodwill attributable to a section 743(b) adjustment, even if some of that goodwill was originally unamortizable and contributed by such acquiring partner to the partnership. However, such discussions also indicate that if the contribution of such unamortizable goodwill and the acquisition that results in the section 743(b) adjustment are part of a series of related transactions, the anti-churning rules will apply to deny amortization with respect to the goodwill contributed by the acquiring partner. It is unclear, however, how the regulations can be read to provide such an exception to the general rule that an acquiring partner may amortize goodwill attributable to a section 743(b) adjustment if such partner is not related to the selling partner.
- (5) Assume that, in the example above, LLC was already classified as a partnership for tax purposes (*e.g.*, P contributed the assets of LLC to a newly formed partnership in exchange for partnership interests, and, at the same time, another party contributed property to the newly formed partnership in exchange for nominal partnership interests), and LLC had a section 754 election in effect. If P then sold 50 percent of its partnership interest to X, X's proportionate share of any basis step-up under section 743 should be amortizable.

33. Example 33 -- Revenue Ruling 98-27

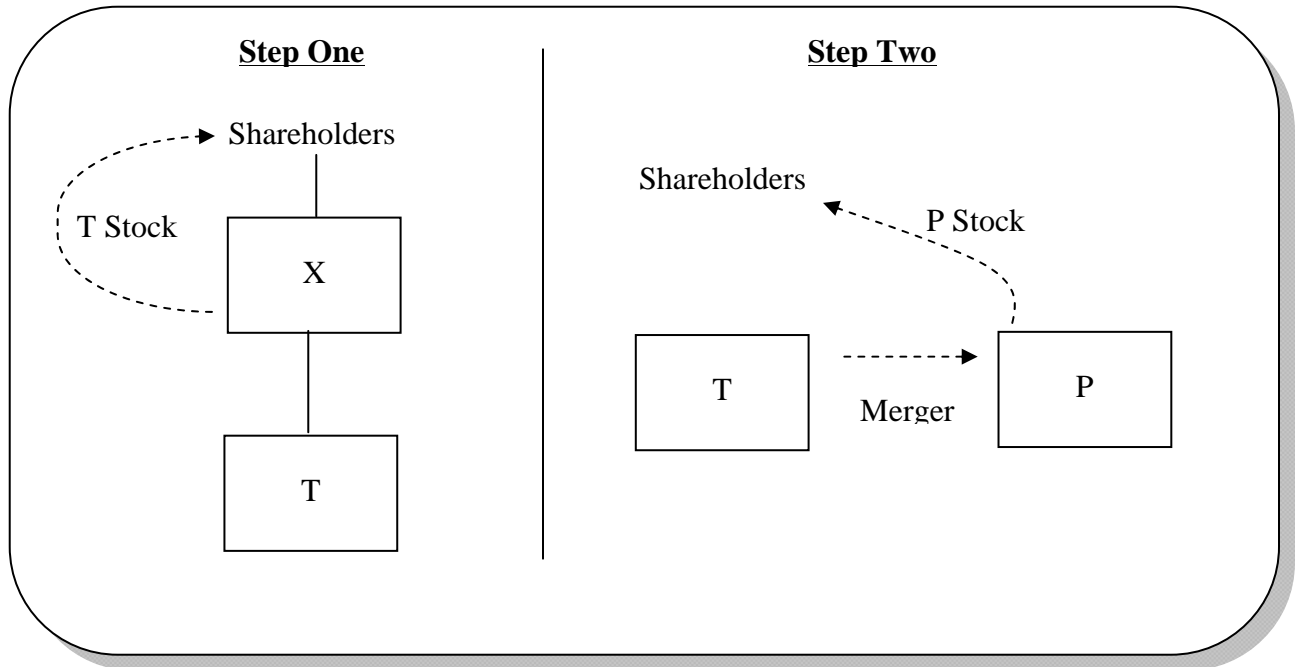

- a. Facts: X corporation owns 100% of the stock of T corporation. X distributes its T stock to its shareholders, pro rata. Soon after the distribution, T and an unrelated corporation, P, enter into negotiations pursuant to which T is merged into P, and T's stock is converted into P stock representing 25% of P's outstanding stock.
- b. Rev. Rul. 96-30. In Rev. Rul. 96-30, 1996-1 C.B. 36 (modifying Rev. Rul. 75-406, 1975-2 C.B. 125), the Service ruled on these facts that the spin-off qualified as a tax-free section 355 transaction followed by a tax-free acquisition, provided that (i) there was a separate and independent shareholder vote after the spin-off approving the acquisition and (ii) the distributing corporation had not entered into negotiations with the acquirer before the spin-off. If either of those conditions were not satisfied, however, the Service indicated that it could reorder the two transactions (so that the acquisition would precede the spin-off distribution) pursuant to the step transaction doctrine. Pursuant to such a reordering, the distributing corporation would be treated as exchanging the stock of its subsidiary for 25% of the acquiring corporation's stock, and then distributing that 25% stock interest to the shareholders of the distributing corporation. Thus, the distributing corporation would not "control" the distributed corporation immediately before the distribution, and would be deemed not to have distributed "control" of the distributed corporation as required by section 355(a)(1)(D). Therefore, the distribution would be fully taxable.

c. Rev. Rul. 98-27.

- (1) Section 355(e): In 1997, Congress added section 355(e), which imposed a corporate-level tax on section 355 distributions that are part of a plan (or series of related transactions) pursuant to which one or more persons acquire stock representing at least a 50 percent or greater interest in the distributing or controlled corporation. The legislative history under section 355(e) indicated that the Service should not apply the section 355 control test to impose additional restrictions on post-distribution restructurings of the controlled corporation, if such restrictions would not apply to the distributing corporation.
- (2) Rev. Rul. 98-27 Obsoletes Rev. Rul. 96-30: Due to the addition of section 355(e) and the legislative history thereunder, the Service on May 14, 1998 issued Revenue Ruling 98-27, which renders obsolete Rev. Rul. 96-30 and Rev. Rul. 75-406. *See* Rev. Rul. 98-27, 1998-1 C.B. 1159. Under Rev. Rul. 98-27, the Service stated that it would no longer apply the step transaction doctrine for purposes of determining “whether the distributed corporation was a controlled corporation immediately before the distribution under section 355(a) solely because of any postdistribution acquisition or restructuring of the distributed corporation, whether prearranged or not.” As a result, Rev. Rul. 98-27 obsoletes Rev. Rul. 96-30 and Rev. Rul. 75-406. Note, however, that any such postdistribution acquisition or restructuring could result in a corporate-level tax under section 355(e).
- (3) Revenue Ruling 98-27 Modifies Rev. Rul. 70-225.
 - a) Rev. Ruls. 96-30 and 75-406 applied to section 355 spin-offs that did not follow a section 368(a)(1)(D) reorganization. In Rev. Rul. 70-225, the Service ruled that a contribution to a controlled corporation (“Controlled”) in a section 368(a)(1)(D) reorganization, followed by a section 355 spin-off of Controlled and subsequent acquisition of Controlled by an unrelated corporation does not qualify as a tax-free transaction. The Service reasoned that a pre-arranged disposition of Controlled stock as part of the same plan as the distribution prevented the transaction from satisfying the requirement under section 368(a)(1)(D) that the distributing corporation's

shareholders be in “control” of the controlled corporation “immediately after” the distribution.

- b) Rev. Rul. 98-27 Modifies Rev. Rul. 70-225: Rev. Rul. 98-27 modified Rev. Rul. 70-225, stating that the Service will no longer apply the step transaction doctrine in determining whether the distributed corporation was a controlled corporation under section 355 immediately before the distribution, i.e., the Service will not reorder the steps of the transaction.
- c) However, as noted below, section 368(a)(2)(H)(ii) effectively made obsolete Revenue Ruling 70-225, and Revenue Ruling 98-44 officially made obsolete Revenue Ruling 70-225. *See* Rev. Rul. 98-44, 1998-2 C.B. 315.

d. Section 368(a)(2)(H) Could Create Triple Tax

- (1) Section 368(a)(2)(H) eliminates the application of the step transaction doctrine to the control test of section 368(a)(1)(D) in a section 355 transaction.
- (2) Under section 368(a)(2)(H), if the requirements of section 355 are met, the fact that the shareholders of the distributing corporation dispose of part or all of their controlled corporation stock will not be taken into account for purposes of determining whether the transaction qualifies under section 368(a)(1)(D). Section 368(a)(2)(H)(ii) In addition, section 368(a)(2)(H) provides that the fact that the controlled corporation issues additional stock will not be taken into account for purposes of determining whether the transaction qualifies under section 368(a)(1)(D). Section 368(a)(2)(H)(ii). Thus, Rev. Rul. 70-225 is effectively rendered obsolete. *See also* Rev. Rul. 98-44, 1998-2 C.B. 315 (rendering Rev. Rul. 70-225 obsolete); PLRs 200029037 (Aug. 3, 1999) and 200001027 (Oct. 8, 1999) (citing section 368(a)(2)(H)(ii) and Rev. Rul. 98-44 to support ruling that taxpayer had accomplished a reorganization under section 368(a)(1)(D)). The Act provides a similar rule for section 351 transactions.
- (3) Although section 368(a)(2)(H) will prevent the Service from applying the step transaction doctrine under the facts of Rev. Rul. 70-225 for purposes of section 368(a)(1)(D), the Act results in the possibility that spin-off transactions will be “triple-taxed.”

- a) For example, assume Distributing contributes the assets of one of its two businesses to newly formed Controlled in exchange for Controlled stock. Assume further that Distributing has a built-in gain in the contributed assets. Distributing then distributes its Controlled stock to its shareholders in a section 355 transaction, and an unrelated party (“Acquiring”) acquires the Controlled stock within two-years of the distribution, in exchange for 5% of Acquiring stock in a tax-free B reorganization.
- b) Under the Act, Distributing will not be taxed on the transfer of assets to Controlled, Controlled will take a carryover basis in the assets received, and Distributing will take a substituted basis in the stock of Controlled (so that Distributing has a built-in gain in that stock). Upon Acquiring's acquisition of Controlled following the distribution of the stock of Controlled, Distributing will be taxed under section 355(e) on the built-in gain in its Controlled stock (if it cannot overcome the presumption that the acquisition is pursuant to a plan that existed at the time of the distribution) (tax # 1).
- c) In addition, Acquiring will be taxed if it sells the stock of Controlled (because under section 362(b), Acquiring's basis in the stock of Controlled is the same as the Distributing shareholders' basis prior to the acquisition, and such basis is not stepped-up as a result of the section 355(e) tax) (tax # 2).
- d) Finally, Controlled will be taxed if it sells the assets received from Distributing (tax # 3).

34. Example 34 – Schering Plough

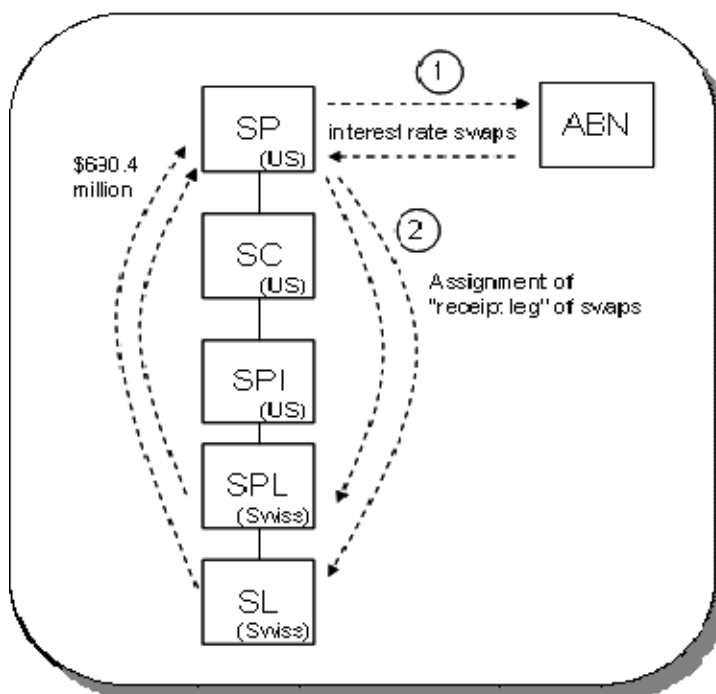

- a. **Facts:** In *Schering-Plough Corp. v. United States*, 104 AFTR 2d 2009-6157 (D.C.N.J. 2009), Schering-Plough Corporation (“SP”) owned all of the stock of Schering Corporation (“SC”), which owned all of the stock of Schering Plough-International (“SPI”). SP, SC, and SPI were U.S. corporations. SPI owned a majority of the voting stock of Schering-Plough Ltd. (“SPL”), which owned a majority share in Scherico, Ltd. (“SL”). SPL and SL were Swiss corporations. SP entered into 20-year interest rate swaps with ABN, a Dutch investment bank, in 1991 and 1992. The swap agreements obligated SP to make payments to ABN based on LIBOR and for ABN to make payments to SP based on the federal funds rate for the 1991 swap and on a 30-day commercial paper rate (plus .05%) for the 1992 swap. The swap agreements permitted SP to assign its right to receive payments under the swaps (the “receipt leg” of the swap). Upon an assignment, SP’s payment to ABN and ABN’s payment to the assignee could not be offset against each other. SP assigned substantially all of its rights to receive interest payments to SPL and SL in exchange for lump-sum payments totaling \$690.4 million.

SP relied on Notice 89-21 to treat the swap and assignment transaction as a sale of the receipt leg of the swap to its foreign subsidiaries (SPL and SL) for a non-periodic payment that could be accrued over the life of the swap.

The IRS issued Notice 89-21 to provide guidance on the treatment of lump-sum payments received in connection with certain notional principal contracts in advance of issuing final regulations. The notice required that a lump-sum payment be recognized over the life of a swap in order to clearly reflect income, stated that regulations would provide the precise manner in which a taxpayer must account for a lump-sum payment over the life of a swap, and provided that similar rules would apply to the assignment of a “receipt leg” of a swap transaction in exchange for a lump-sum payment. Taxpayers were permitted to use a reasonable method of allocation over the life of a swap prior to the effective date of the regulations. However, the notice also cautioned that no inference should be drawn as to the treatment of “transactions that are not properly characterized as notional principal contracts, for instance, to the extent that such transactions are in substance properly characterized as loans.”

The IRS issued final regulations in 1993 that reversed the basic conclusion of Notice 89-21 and provided that an assignment of the “receipt leg” of a swap for an up-front payment (when the other leg remained substantially unperformed) could be treated as a loan. See Treas. Reg. 1.446-3(h)(4) and (5), ex. 4.

The IRS argued that the swap and assignment transaction should be treated as a loan from the foreign subsidiaries to SP, which would trigger a deemed dividend under section 956.

- b. Issue – Whether the transaction was a loan or an assignment
- (1) The District Court found in favor of the government on four separate grounds that, in the court’s view, would be sufficient to deny the taxpayer’s claim for tax-deferred treatment under Notice 89-21.
 - (2) Substance Over Form
 - a) The court noted that the integrated transaction had the effect of a loan in which SP borrowed an amount from its foreign subsidiaries in exchange for principal and interest payments that were routed through ABN.
 - b) The court discounted SP’s arguments (i) that there was an absence of customary loan documentation, (ii) that SP did not directly owe an amount to the foreign subsidiaries (even if ABN failed to fulfill its obligations), and (iii) that the amount of interest paid by SP to ABN would not equal the amount

received by its foreign subsidiaries because of the different interest rate bases used under the swap. The court determined that SP's efforts to structure the transactions as sales failed to overcome the parties' contemporaneous intent and the objective indicia of a loan. The court stated that the foreign subsidiaries received the "economic equivalent" of interest and noted that SP "consistently, materially, and timely made repayments" to its foreign subsidiaries. The court found that SP officials considered the transaction to be a loan. The court observed that SP did not use customary loan documentation for intercompany loans. The court also concluded that ABN was a mere conduit for the transactions which, according to the court, further supported its holding that the transactions were, in substance, loans. ABN faced no material risk since it entered into "mirror swaps" to eliminate interest rate risk (but not the credit risk of SP). The court found that ABN did not have a bona fide participatory role in the transactions, operating merely as a pass-through that routed SP's repayments to the Swiss subsidiaries.

(3) Step Transaction

- a) The court also applied the step transaction doctrine as part of its substance over form analysis to treat the swap and assignment transaction as a loan.
- b) In applying the "end-result test," the court determined that the steps of the swap and assignment transaction could be collapsed because they all functioned to achieve the underlying goal of repatriating funds from the foreign subsidiaries (SPL and SL).
- c) In the court's view, the evidence established that the swaps and subsequent assignments were pre-arranged and indispensable parts of a "broader initiative" of repatriating earnings from the foreign subsidiaries.
- d) The court also concluded the steps of the swap-and-assign transactions to be interdependent under the "interdependence test."

- e) The court found that the goal of the interlocking transactions was to repatriate foreign-earned funds, and the interest rate swaps would have been pointless had SP not subsequently entered into the assignments with its subsidiaries.
 - f) The court rejected SP's argument that, in applying the step transaction doctrine, the IRS created the fictitious steps that (i) the foreign subsidiaries loaned funds to SP, (ii) SP entered into an interest rate swap for less than the full notional amount with ABN, and (iii) SP satisfied its obligation under the imaginary loans by directing ABN to make future payments under the swap to its foreign subsidiaries.
 - g) The court also rejected SP's argument that the step transaction doctrine should not apply because the IRS failed to identify any meaningless or unnecessary steps.
- (4) Economic Substance
- a) The court concluded that the swap and assignment transaction failed the economic substance doctrine and, thus, SP was not entitled to tax-deferred treatment.
 - b) The court followed 3rd Circuit precedent, *ACM Partnership v. Commissioner*, 57 F.3d 231 (3d. Cir. 1998), which treats the "objective" and "subjective" elements of the doctrine as relevant factors (rather than applying a rigid conjunctive or disjunctive standard).
 - c) The court rejected the taxpayer's position that the repatriation proceeds represented "profit" from the transaction. The court also noted that any interest rate risk due to the swaps was hedged and that SP incurred significant costs in executing the transaction. In sum, the court found that there was little, if any, possibility of a pre-tax profit.
 - d) The court concluded that both the swap and assignment lacked a business motive.
 - e) SP contended that it entered into both swaps for cash management and financial reporting objectives, the 1991 swap for hedging purposes, and the 1992 swap for a yield enhancement function.

The court rejected each of these non-tax motivations.

- f) Notably, the court avoided the difficult legal determination of whether the court must examine the whole transaction or, as the government argued, just the component part that gave rise to the tax benefit (here, the assignment step of the transaction).

(5) Subpart F Principles

- a) The court determined that permitting the repatriation of \$690 million in offshore earnings without at least a portion of those earnings being captured under subpart F would contradict Congressional intent.
- b) The court noted that Notice 89-21 did not supplant, qualify, or displace subpart F, nor was the notice intended to permit U.S. shareholders of controlled foreign corporations to repatriate offshore revenues without incurring an immediate tax.
- c) In the court's view, the notice only dealt with the timing of income recognition.

35. Example 35 – Fidelity International

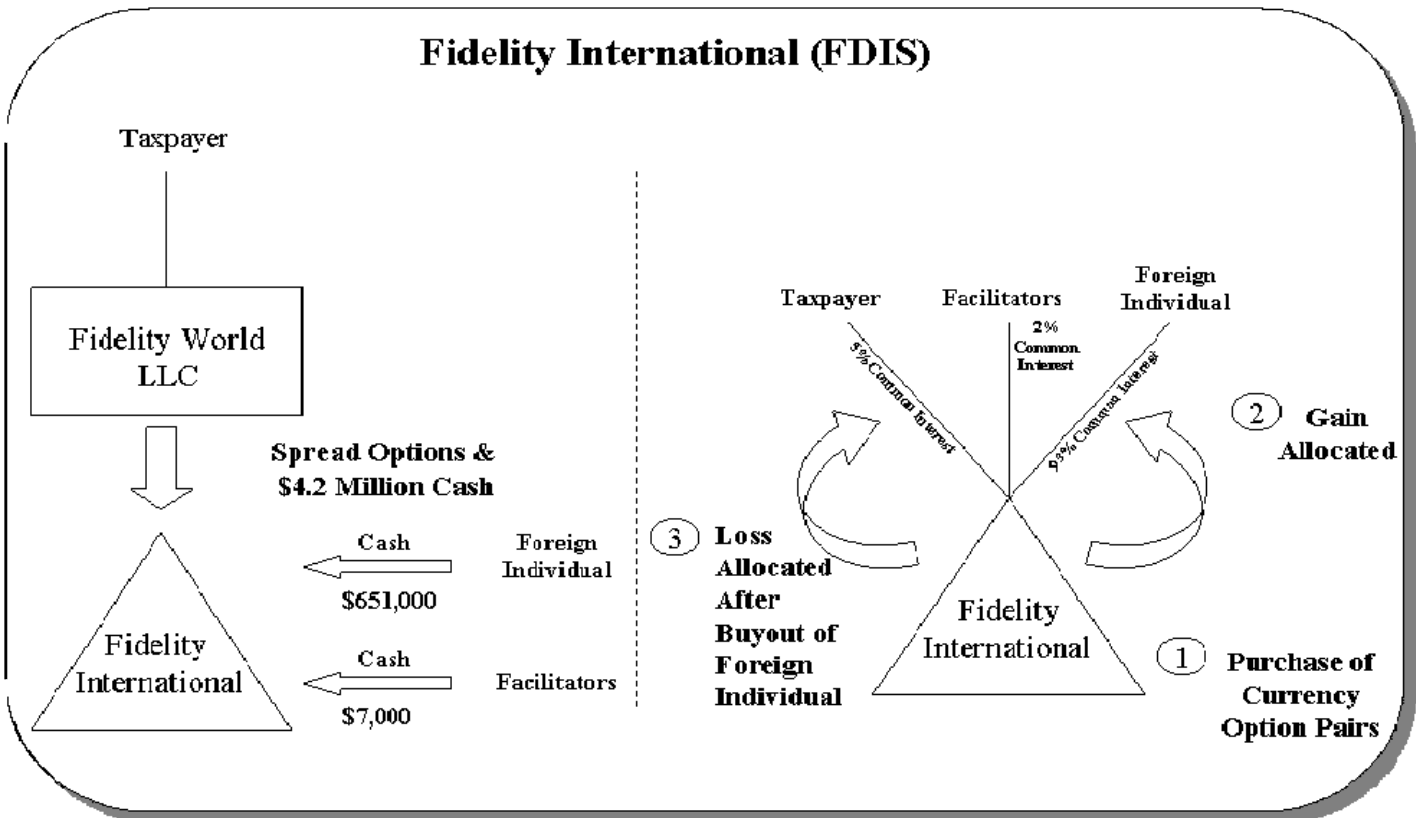
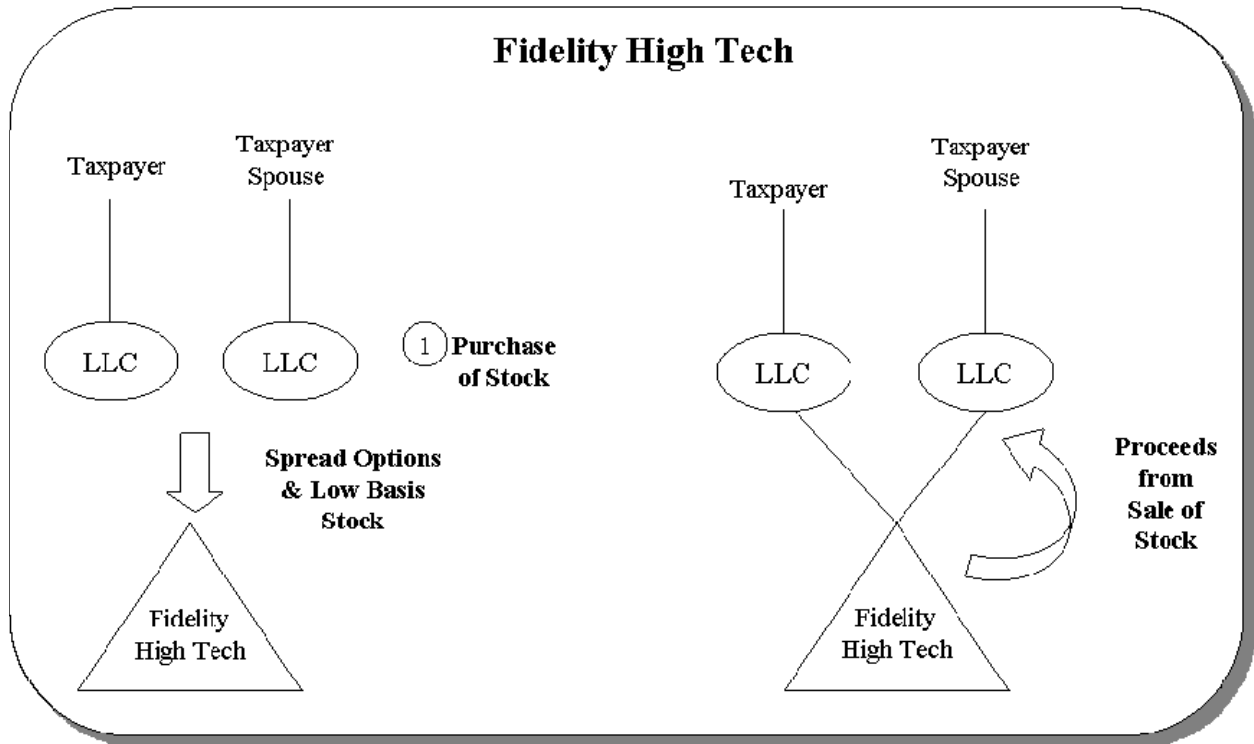

- a. Facts The District Court of Massachusetts held that certain Son-of-BOSS type transactions should be disregarded because they lacked economic substance and because of the step transaction doctrine. *See Fidelity Int'l Currency Advisor A Fund LLC v. United States*, 105 AFTR 2d 2010-2403 (D.C. Mass. 2010). Taxpayers owned approximately 25 million shares of EMC stock. In 2000, taxpayers' basis in the stock was extremely small in comparison to the stock's trading price, and the sale of any portion of the stock would have resulted in substantial capital gains. Taxpayers also owned options to purchase an additional 8 million shares of EMC stock at very low strike prices. The exercise of the options would generate significant amounts of ordinary income. To avoid the large tax liabilities that would result from a stock sale or exercise of the stock options, taxpayers invested in two son-of-BOSS style tax shelters promoted by KPMG. The first transaction involved the contribution of offsetting options (in large notional amounts) which were purchased by two single member LLCs with the taxpayer and his wife as the only members and the contribution of low basis EMC and other stock to Fidelity High Tech Advisor A Fund, LLC, which was taxed as a partnership. Taxpayers treated the purchased option as an asset, but the sold option was not treated as a liability. Thus, the taxpayers contributed assets to the partnership entity but not liabilities, creating an inflated basis in their membership interest of more than \$163 million. In 2002, the taxpayers sold all of the stock in Fidelity High Tech and claimed a significant capital loss.

Taxpayers used a second transaction, the Financial Derivatives Investment Strategy ("FDIS"), a variation of the scheme discussed above, to shelter ordinary income resulting from the exercise of their EMC stock options. The FDIS transaction, executed through Fidelity World, a single member LLC, and Fidelity International Currency Advisor A Fund, LLC, a partnership, involved the generation of losses and gains through currency options with the gains assigned to the offshore partner, an Irish confederate of the tax promoters, and the losses were assigned to the taxpayer after the foreign partner was bought out. The Fidelity International transaction resulted in the creation of artificial losses of \$158.6 million in 2001, which the taxpayers used to offset the ordinary income of \$162.9 million from the option exercise on their income tax return that year.

- b. Issue – Whether taxpayer was entitled to the losses claimed.
- (1) Economic Substance – The Court focused primarily on the lack of economic substance for the two transactions. The court stated that the First Circuit appears to have adopted a version of the economic substance doctrine that looks to

both the subjective and objective features of the transactions, without applying a rigid two-part test (citing *Dewees v. Comm'r*, 870 F.2d 21 (1st Cir. 1989)). Taxpayers relied on several other First Circuit opinions, including *Granite Trust Co. v. United States*, 238 F.2d 670 (1st Cir. 1956), for the proposition that a transaction that is not fictitious should be upheld, without regard to the subjective intent of the taxpayer. The court, however, stated that the *Dewees* opinion effectively overruled *Granite Trust* (as well the other cases cited by taxpayers), “at least as to the broad contours of the economic substance doctrine.” The court stated that *Dewees* is in accordance with the view shared by most circuits, that a court may take into account both objective and subjective factors in assessing whether a particular transaction had economic substance. Accordingly, to the extent the cases cited by taxpayers may be read to support the proposition that a taxpayer’s subjective intent is irrelevant, that proposition cannot survive the holding or the reasoning of *Dewees*. The court concluded that, in making an economic substance determination, it considers both the objective features of the transactions and the subjective intent of the participants, including the overall features of the tax shelter scheme and the intentions of the promoters. The court noted, however, that it was not necessary to decide whether the objective or subjective factors, standing alone, would be sufficient to support a finding of a lack of economic substance in this case, as the transactions at issue were without economic substance under either an objective or subjective analysis.

- (2) Step Transaction – The Court also held that the step transaction doctrine applied to each of the transactions.
 - a) Fidelity High Tech Transaction - The court held that the interdependence test applied to collapse the steps. The court found that none of the individual steps had an independent business purpose and that all of the steps were set out in memos or outlines prepared by the promoters. In addition, each step was undertaken solely for the purpose of gaining a stepped up basis, and the individual steps would have been pointless without the completion of the entire preplanned transaction. Ultimately the court determined that options contributed to Fidelity High Tech from the LLCs should be “treated as having been acquired in the first instance by High Tech.” This would prevent the taxpayer from receiving the stepped up basis in the partnership.

- b) Fidelity International Transaction – The court similarly held that the interdependence test applied to collapse the steps of this transaction. Again, none of the individual steps had an independent business purpose, all but two of the steps were outlined in memos and notes from the promoter, and the two steps were orally communicated to the taxpayer. The promoter was aware of the potential IRS claim for the step transaction doctrine, and although the taxpayer tried to lengthen the time between steps the court determined that each step was completely interdependent. The Court concluded that the contribution of options to Fidelity International from Fidelity World should be collapsed, and the options “should be treated as having been acquired in the first instance by Fidelity International.” In the alternative the court held that the taxpayer should be treated as realizing both the gain and the loss in the transaction, but does not clearly explain how the step transaction doctrine would create this result.